

Solenoid Concept: New generation of top performing solenoid cartridge valves.

PATENT PENDING



1
2/2 Pilot operated
poppet type
Normally closed
Max. pressure: 350 bar (5000 psi)
Max. flow: 40 lpm (11 gpm)

2
2/2 Pilot operated
poppet type
Normally open
Max. pressure: 350 bar (5000 psi)
Max. flow: 40 lpm (11 gpm)

3
3/2 Direct acting
spool type
Max. pressure: 210 bar (3000 psi)
Max. flow: 20 lpm (5 gpm)

4
4/2 Direct acting
spool type
Max. pressure: 210 bar (3000 psi)
Max. flow: 20 lpm (5 gpm)

Description:

Design of Bosch Rexroth Compact Hydraulics NEW solenoid cartridge valves and coils incorporating a new solenoid concept providing excellent performance which enables new valves to work in severe environment conditions.

1. Features

- Introduction of new 16mm diameter pole tube.
- Introduction of new design concept of hydraulic parts (Patent Pending)
- New D36 coil with round shape 36mm diameter

2. Performance improvements:

- Leakage \leq 5 drops per minutes.
- Max ambient temperature range now upgraded to 90°C
- Cycle life improved up to 2 million cycles
- Larger admissible voltage fluctuations

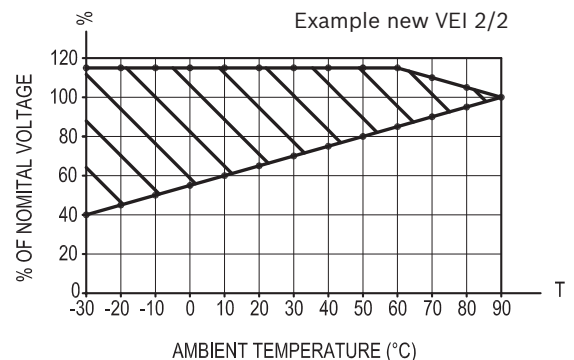

3. Current and New valves size comparison:

- The new valves will maintain the same cavity compared to the current versions, granting perfect interchangeability
- The new round shape allows easier positioning / turning of the coil compared to former square design.
- Improvement in terms of overall compactness, optimizing block configuration.

Please find below the overall dimension changes of the nr.4 cartdrges presented.

1 2/2 Pilot operated, poppet type, normally closed

Old code
OD1505183AS000

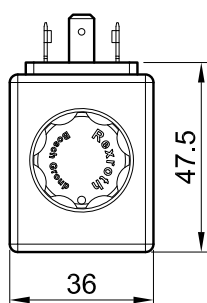
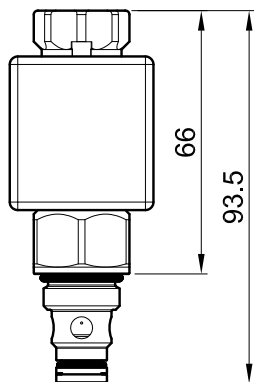

Old code
V389664A20

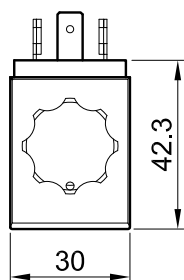
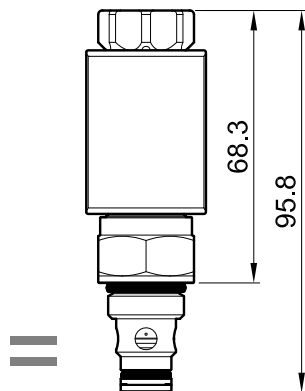

NEW code
OD150518A.....

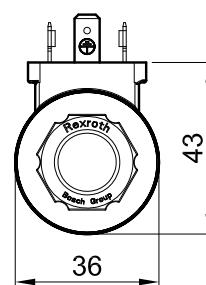
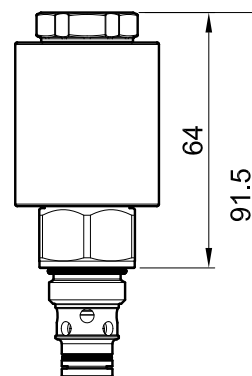
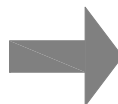

2 2/2 Pilot operated, poppet type, normally open

Old code
OD1506181AS000

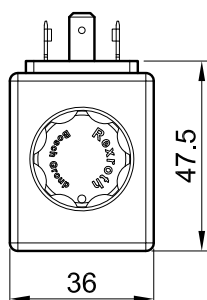
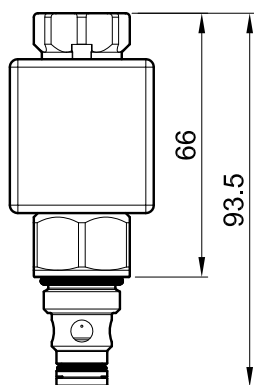

Old code
V389664B20

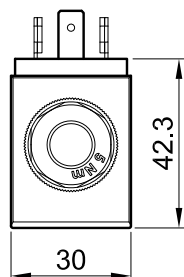
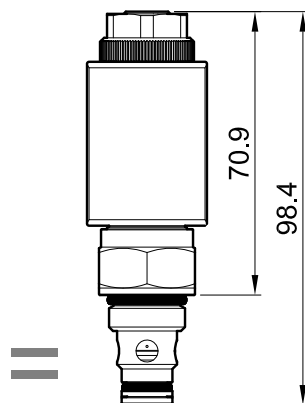

NEW code
OD150618A.....

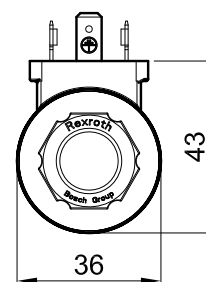
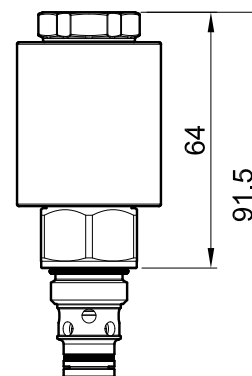
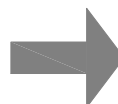

3 3/2 Direct acting, spool type

Old code
OD131051300000

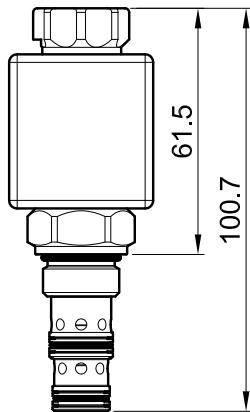

Old code
V389655A00

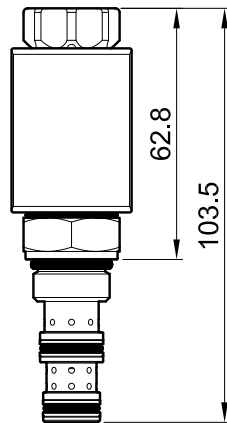

NEW code
OD131051A.....

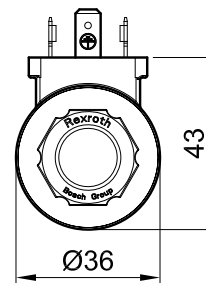
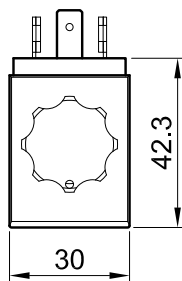
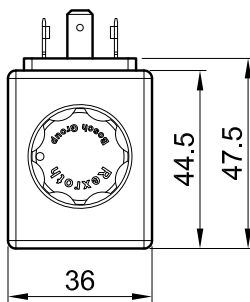
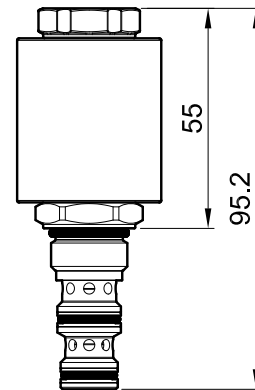

4 4/2 Direct acting, spool type

Old code
OD144058300000

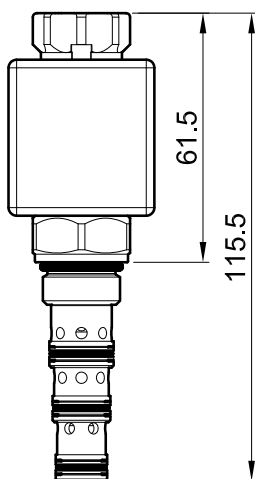

Old code
V389656A00

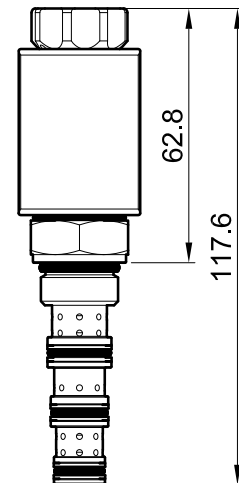

NEW code
OD144058A.....

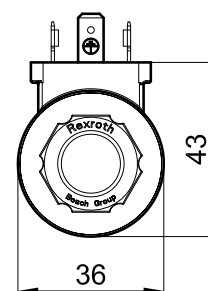
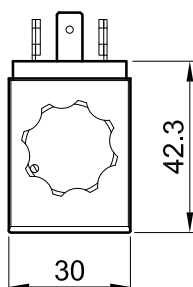
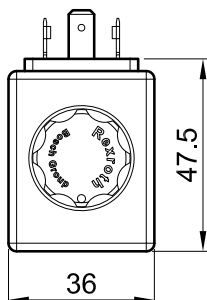
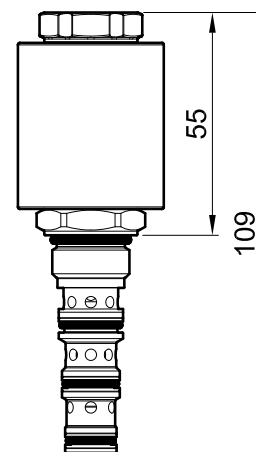

New D36 coil, technical info:

- New coil Family D36 provides the basis for Bosch Rexroth 'New Solenoid Concept' Cartridge Valves with optimized technical performance suited for broader bandwidth of applications. The rugged design allows the valve equipped with this coil system to be used also in the harshest environments in mobile machinery applications. The coils exceed IP69K standard, are tested under harsh vibration and temperature cycle conditions and provide an excellent long-term operation. The fully plastic overmolded design provides chemical resistance against corrosion induced by salt-spray or chemicals (e.g. Agriculture)

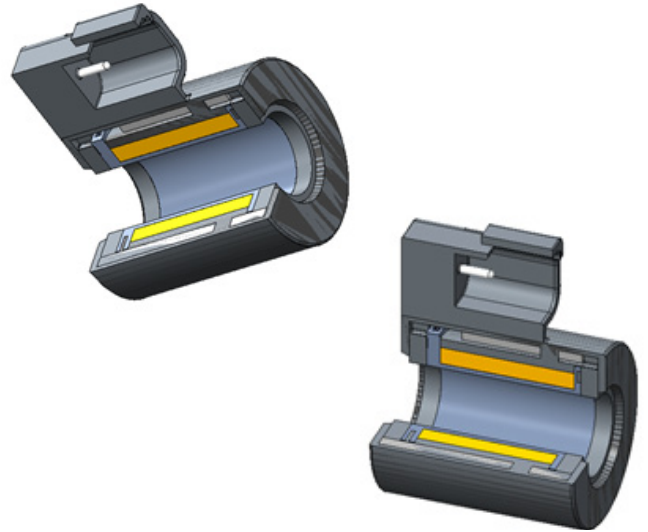

- DC power supply
- Power 20W
- Voltages available 12,24,48, 96, 205 Volt (see connectors versions)
- The external plastic rugged shell provides protection against physical damage and ensures resistance against harsh operating conditions (salt water spray / agricultural chemicals etc.)
- The coil is designed with a protective layer of encapsulated plastic. A special molding technique prevents moisture build-up while the plastic is applied.
- Round shape allows easier positioning / turning of the coil compared to square design.
- High input voltage tolerance
- D36 coils have passed the drop test, vibration test, and the mechanical shock test.
- The D36 coils are designed to be highly water and chemical resistant. They have passed comprehensive tests for salt fog, chemical splash, and humidity.
- Bosch Rexroth test is according to EN 60529 (to ensure tightness of the coil against water infiltration)

IP-Test: **IPX5; IPx9k** Water Jet test

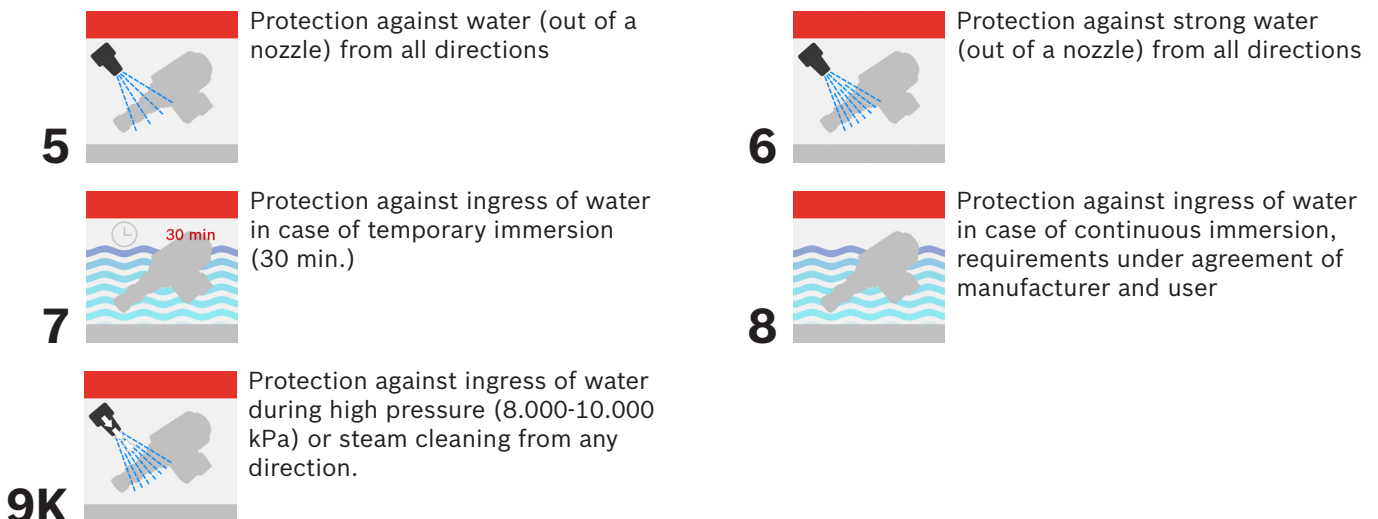

- Thermal Shock Dunk Test Rated: all D36 coils have passed a salt water dunk test. D36 coils with Deutsch DT and Metri-Pack connectors have passed an even more rugged test pattern to fulfill highest customer demands in the construction, agricultural and mobile equipment markets
- High Temperature Operation: Class H magnetwire and insulation materials allow high temperature operation and ensure long life under demanding conditions.
- IP69K with Integral Connectors: D36 coils with Deutsch, Amp-Super Seal and Metri-Pack are environmentally rated IP69K (Dual Leads / Single lead in validation); DIN and KOSTAL are rated IP65, AMP Junior
- UL Certification available: D36 coils with Deutsch, Amp Junior and DIN connector are available as UL rated version and therefore usable in any applications requiring UL certification. (Package E300N)
- Bi-Directional Diodes: available with all connectors options. The bi-directional TVS suppressor diode (P6KE22CA) is not polarity-dependent and therefore does not require the alignment of the coil terminals during installation which will mistake proof electrical installations.
- Connectors versions:

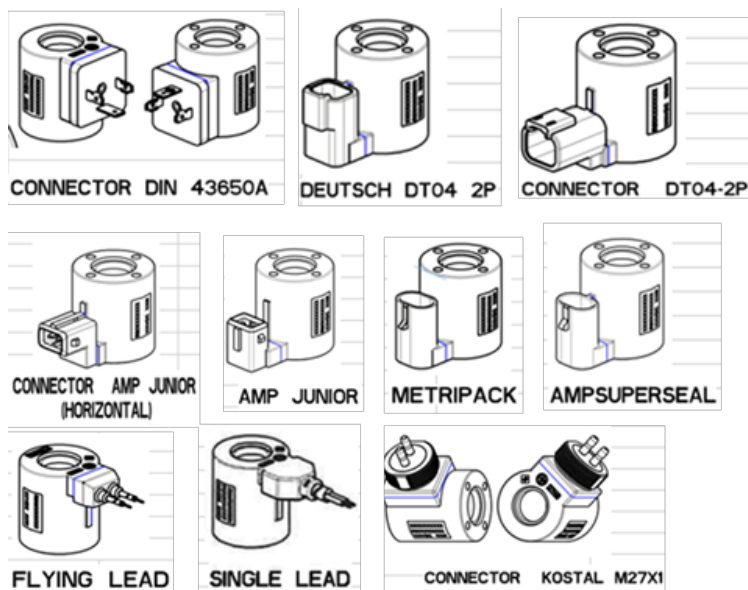

Connector type	Voltages available (V)				
	12	24	48	96	205
DIN	X	X	X	X	X
DIN UL	X	X	X	X	X
DEUTSCH (Vertical)	X	X	X		
DEUTSCH (Vert UL)	X	X	X		
DEUTSCH (Horiz.)	X	X	X		
AMP JUNIOR (Vert.)	X	X	X		
APM JUNIOR (Horiz.)	X	X	X		
AMP JUNIOR (Horiz. UL)	X	X	X		
KOSTAL	X	X	X		
DUAL LEAD	X	X	X		
SINGLE LEAD	X	X	X		
AMP J SUPERSEAL	X	X	X		
METRIPACK	X	X	X		

The new generation of solenoid cartridge valves and coils will be phased-in gradually, starting from April 2016 until end of 2017.