



Torqmotor™

Series

TE / TJ / TF / TL / TG / TH / TK

aerospace
climate control
electromechanical
filtration
fluid & gas handling
hydraulics
pneumatics
process control
sealing & shielding



ENGINEERING YOUR SUCCESS.

DE Hinweis

Die in diesem Katalog oder in Form anderer Informationen durch die Parker Hannifin GmbH, ihre Niederlassungen, Vertriebsbüros oder ihre autorisierten Werksvertretungen gemachten Angaben sind für Anwender mit Sachkenntnissen bestimmt. Vom Anwender ist eine Überprüfung der über das ausgewählte Produkt gemachten Angaben auf Eignung für die geforderten Funktionen erforderlich. Bedingt durch die unterschiedlichen Aufgaben und Arbeitsabläufe in einem System muss der Anwender prüfen und sicherstellen, dass durch die Eigenschaften des Produkts alle Forderungen hinsichtlich Funktion und Sicherheit des Systems erfüllt werden.

UK Note

This document and other information from Parker Hannifin GmbH, its subsidiaries, sales offices and authorized distributors provide product or system options for further investigation by users having technical expertise. Before you select or use any product or system it is important that you analyse all aspects of your application and review the information concerning the product or system in the current product catalogue. Due to the variety of operating conditions and applications for these products or systems, the user, through his own analysis and testing, is solely responsible for making the final selection of the products and systems and assuring that all performance and safety requirements of the application are met. The products are subject to change by Parker Hannifin GmbH at any time without notice.

FR Note

Les indications données dans le présent catalogue ainsi que toutes autres informations fournies par Parker Hannifin GmbH, ses succursales, ses bureaux de vente ou ses représentations d'usine autorisées sont destinées aux utilisateurs ayant des connaissances techniques en la matière. L'utilisateur devra procéder à une vérification des indications faites sur le produit sélectionné pour savoir s'il est bien approprié aux fonctions demandées. Dû aux conditions environnementales variées dans les quelles ces composants et ces systèmes doivent opérer, l'utilisateur doit vérifier et s'assurer que les propriétés du produits répondent bien à toutes les exigences relatives au fonctionnement et à la sécurité du système.

IT Avvertenza

Le indicazioni fatte nel presente catalogo o sotto forma di altre informazioni dalla Parker Hannifin GmbH, dalle sue filiali, uffici di vendita o dalle sue consociate autorizzate, sono destinate a utenti con conoscenze tecniche. L'utente è tenuto a verificare che le indicazioni fatte sul prodotto scelto siano conformi alle funzioni richieste. A causa delle diverse applicazioni e condizioni d'impiego, l'utente deve verificare e assicurare che le proprietà del prodotto soddisfino tutte le esigenze relative al funzionamento e alla sicurezza del sistema.

Introduction

Excellence of Design

The producers of Parker Hannifin's **Torqmotor™** Series motors have a history of manufacturing reliable, precision parts that stretches back over a century. Milestones include the first patent on roller vane rotor sets for low speed, high torque hydraulic motors. That was forty years ago. Today the technological advances continue.

In the Development Laboratory, engineers continuously measure and analyze motor data to move existing products to even higher levels of performance and to develop new products to serve the ever changing needs of our customers. Design integrity is assured by exhaustive testing on endurance stands. To be sure that this translates into superior performance, advanced manufacturing techniques are employed as well.

Excellence of Manufacturing

Central to manufacturing excellence is the understanding that quality parts make quality motors. The instrumentation in our Quality Assurance laboratory includes devices such as coordinate measuring machines, to accurately measure the parts that we manufacture as well as those that we purchase. Quality cannot be inspected in, however. It must be manufactured. Each machine operator is responsible for the quality of the part that comes off that machine. Efficiency is enhanced by our cellular manufacturing techniques. Accuracy is assured by statistical process control methods. Micrometers and specialized gages are at the disposal of the operator. As a final check, every motor is tested before shipment to our customer. Parker understands that our customers cannot produce quality products unless we do.



Contents

Series	DE	UK	FR	IT	Page
TE/TJ	Merkmale	Features	Caractéristique	Carratteristiche	6
TE/TJ	Kenndaten	Performance	Puissance	Prestazioni	7
TE/TJ	Gehäuse	Housing	Carter	Corpo	8
TE/TJ	Anschlüsse	Ports	Orifices	Connessioni	10
TE/TJ	Endanschluss	Rear Ports	Orifices arrières	Connessioni posteriori	11
TE/TJ	Abtriebswelle	Coupling shaft	Arbre	Alberi	12
TE/TJ	Diagramme	Diagrams	Diagrammes	Diagrammi	13
TE/TJ	Lebensdauer	Life Time	Durée de vie	Durata	16
TE/TJ	Bestellschlüssel	Ordering Code	Système d. commande	Sistema di ordinazione	17
TE/TJ	Schockventil	Crossover relief valve	Valve antichoc	Valvola anti-urto	19
TE/TJ	Spülventil	Hot oil shuttle valve	Valve de rinçage	Valvola di scambio	20
TE/TJ	Drehzahlsensor	Speed sensor	Compte-tours	Contagiri	21
TF	Merkmale	Features	Caractéristique	Carratteristiche	22
TF	Kenndaten	Performance	Puissance	Prestazioni	23
TF	Gehäuse	Housing	Carter	Corpo	24
TF	Anschlüsse	Ports	Orifices	Connessioni	26
TF	Endanschluss	Rear Ports	Orifices arrières	Connessioni posteriori	27
TF	Abtriebswelle	Coupling shaft	Arbre	Alberi	28
TF	Diagramme	Diagrams	Diagrammes	Diagrammi	30
TF	Lebensdauer	Life Time	Durée de vie	Durata	32
TF	Bestellschlüssel	Ordering Code	Système d. commande	Sistema di ordinazione	33
TL	Merkmale	Features	Caractéristique	Carratteristiche	34
TL	Kenndaten	Performance	Puissance	Prestazioni	35
TL	Gehäuse	Housing	Carter	Corpo	36
TL	Anschlüsse	Ports	Orifices	Connessioni	37
TL	Endanschluss	Rear Ports	Orifices arrières	Connessioni posteriori	37
TL	Abtriebswelle	Coupling shaft	Arbre	Alberi	37
TL	Diagramme	Diagrams	Diagrammes	Diagrammi	38
TL	Lebensdauer	Life Time	Durée de vie	Durata	39
TL	Bestellschlüssel	Ordering Code	Système d. commande	Sistema di ordinazione	40
TG	Merkmale	Features	Caractéristique	Carratteristiche	41
TG	Kenndaten	Performance	Puissance	Prestazioni	42
TG	Gehäuse	Housing	Carter	Corpo	43
TG	Anschlüsse	Ports	Orifices	Connessioni	45
TG	Endanschluss	Rear Ports	Orifices arrières	Connessioni posteriori	46
TG	Abtriebswelle	Coupling shaft	Arbre	Alberi	47
TG	Diagramme	Diagrams	Diagrammes	Diagrammi	49
TG	Lebensdauer	Life Time	Durée de vie	Durata	51
TG	Bestellschlüssel	Ordering Code	Système d. commande	Sistema di ordinazione	52
TH	Merkmale	Features	Caractéristique	Carratteristiche	53
TH	Kenndaten	Performance	Puissance	Prestazioni	54
TH	Gehäuse	Housing	Carter	Corpo	55
TH	Anschlüsse	Ports	Orifices	Connessioni	56
TH	Abtriebswelle	Coupling shaft	Arbre	Alberi	56
TH	Endanschluss	Rear Ports	Orifices arrières	Connessioni posteriori	57
TH	Diagramme	Diagrams	Diagrammes	Diagrammi	58
TH	Lebensdauer	Life Time	Durée de vie	Durata	60
TH	Bestellschlüssel	Ordering Code	Système d. commande	Sistema di ordinazione	61

Contents

Series	DE	UK	FR	IT	Page
TK	Merkmale	Features	Caractéristique	Carratteristiche	62
TK	Kenndaten	Performance	Puissance	Prestazioni	63
TK	Gehäuse	Housing	Carter	Corpo	64
TK	Endanschluss	Rear Ports	Orifices arrières	Connessioni posteriori	65
TK	Abtriebswelle	Coupling shaft	Arbre	Giunto	66
TK	Diagramme	Diagrams	Diagrammes	Diagrammi	67
TK	Lebensdauer	Life Time	Durée de vie	Durata di vita	68
TK	Bestellschlüssel	Ordering Code	Système d. commande	Sistema di ordinazione	69
TF/TG/TH/TK	Beispiel	Example	Exemple	Esempio	70
TF/TG	Schockventil	Crossover relief valve	Valve antichoc	Valvola anti-urto	71
TF/TG/TH					72
TF/TG	Spülventil	Hot oil shuttle valve	Valve de rinçage	Valvola di scambio	73
TH					74
TF/TG	Drehzahlsensor	Speed sensor	Compte-tours	Contagiri	75
BG	Merkmale	Features	Caractéristique	Carratteristiche	78
BG	Bestellschlüssel	Ordering Code	Système d. commande	Sistema di ordinazione	79
all	Optionen Codes	Option Codes	Option Codes	Codici opzioni	80
all	Betrieb	Operation	Mise en service	Istzuzioni pez l' uso	81
all	Produktübersicht	Motor range	Gamme de moteurs	Gamma di motori	82

Features

- **Langsamlaufender Gerotor-Motor**
- **Spezielle Orbital-Steuerung**
Geringe interne Leckage
Hoher volumetrischer Wirkungsgrad
- **Rollen im Rotorsatz**
Reduzierte Reibung
Lange Lebensdauer
- **Patentierte Hochdruckwellendichtung**
Keine Leckölleitung
Keine Rückschlagventile
- **Vielzahl von Varianten**
Großer Einsatzbereich

**Torqmotor
Series TE-TJ**

- **Low Speed Gerotor Motor**
- **Zero leak commutation valve**
For greater, more consistent
Volumetric efficiency
- **Roller vane rotor set**
Reduces friction and internal leakage
Maintaining efficiency throughout the life of the motor
- **Patented high-pressure shaft seal**
No check valves needed
No extra plumbing
- **Wide choice of displacement range, flange and shaft options**
Greater efficiency in systems design
to suit your application

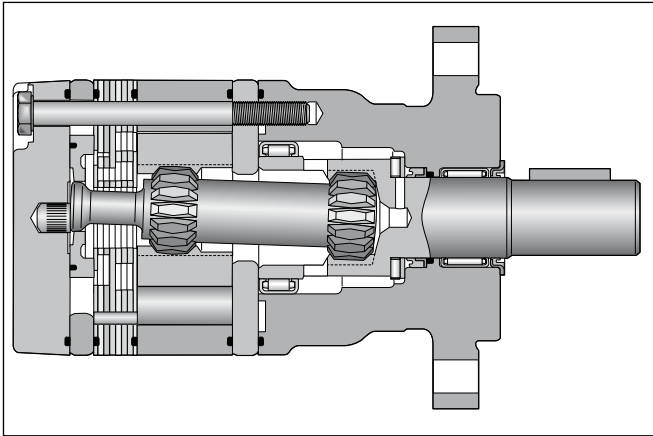
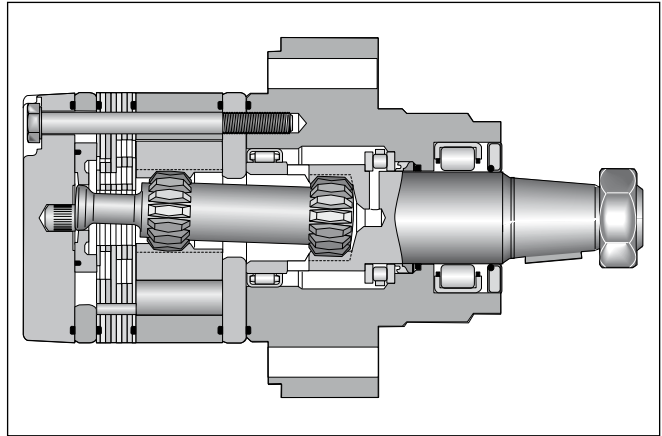
Series TE**Series TJ**

- **Moteur lent système Gerotor**
- **Une distribution orbitale particulière assure**
fuites internes minimales
rendements volumétriques élevés
- **Le rotor à rouleaux**
réduit les frottements
augmente la durée de vie
- **Par l'utilisation de joints d'arbre haute pression brevetés**
pas de conduite de drainage
pas de clapets anti-retour
- **Grâce à de nombreuses variantes**
larges domaines d'applications

- **Motore orbitale a bassa velocità**
- **Una particolare distribuzione orbitale assicura**
trafilamento ridotto elevato rendimento volumetrico
- **Con lo statore a rullo**
si riduce l'attrito interno
si mantiene nel tempo l'efficienza del motore
- **Una guarnizione di tenuta ad alta pressione brevettata elimina la necessità**
di una linea di drenaggio esterna e di valvole non ritorno
- **Un'ampia gamma di cilindrate, flangiature ed alberi**
consentono scelte adeguate ad ogni esigenza costruttiva

Performance

Drehzahl Speed Vitesse de rotation Velocità di rotazione	5...1160 rev/min
Schluckstrom Oil flow Débit d'huile Portata	max. 75 l/min
Eingangsdruck Supply pressure Pression entrée Pressione in entrata	max. 200 bar
Drehmoment Torque Couple Coppia	max. 550 Nm
Seitenlast Side load Charges latérales Carico radiale	TE = max. 7000 N TJ = max. 14000 N

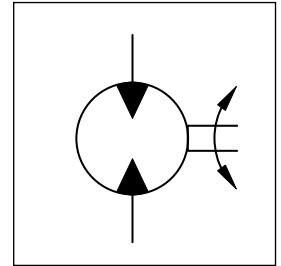
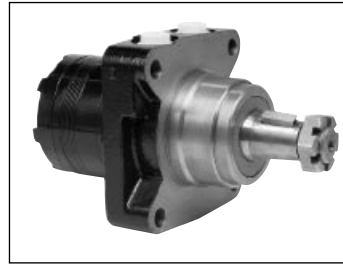

Series TJ



Series TE

Motor series TE / TJ	Geom. Schluckvolumen Geometric displacement Cylindrata Max. Drehzahl Max. speed Vitesse de rotation maxi Velocità di rotazione maxi Max. Schluckstrom Max. oil flow Portata max Max. Druckdifferenz * Chute de differential pressure * Caduta di pressione max * Max. Eingangsdruck Max. supply pressure Pression maxi entrée Pressione max in entrata Max. Drehmoment Max. torque Couple maxi Coppia max Max. Leistungabgabe Max. performance Potenza meccanica max Min. Anlaufmoment Min. starting torque Couple min. di avviamento Coppia min. di spunto	[cm ³ /U [cm ³ /rev]	cont / int [U/min [rev/min]	cont / int [l/min]	cont / int [bar]	max [bar]	cont / int [Nm]	cont / int [KW]	cont / int [Nm]
TE/TJ 36	36	930/1160	35/40	140/190	200	55/71	9	44/52	
TE/TJ 45	41	810/1024	35/41	140/190	200	70/100	10	44/64	
TE/TJ 50	50	725/1020	35/50	140/190	200	90/127	13	72/98	
TE/TJ 65	66	705/940	45/60	140/190	200	125/176	15	100/137	
TE/TJ 80	82	560/750	45/60	140/190	200	160/220	17	128/171	
TE/TJ 100	98	470/630	45/60	140/190	200	190/264	17	152/205	
TE/TJ 130	130	350/470	45/60	140/190	200	255/352	17	204/274	
TE/TJ 165	163	280/375	45/60	140/190	200	310/436	17	248/338	
TE/TJ 195	196	235/315	45/60	140/190	200	390/528	17	312/411	
TE/TJ 230	228	265/330	60/75	120/165	200	380/514	18	304/411	
TE/TJ 260	261	230/290	60/75	110/155	200	400/550	17	320/449	
TE/TJ 295	293	200/255	60/75	100/145	200	428/582	16	328/445	
TE/TJ 330	326	185/235	60/75	100/135	200	443/600	15	344/453	
TE/TJ 365	370	150/200	60/75	95/125	200	467/648	14	373/477	
TE/TJ 390	392	152/190	60/75	85/120	200	445/628	13	348/462	

int. = Intermittierende Werte maximal: 10% von jeder Betriebsminute.
Intermittent operation rating applies to 10% of every minute.
Fonctionnement interm.: 10% max. de chaque minute d'utilisation.
Servizio intermittente: 10% max di ogni minuto di utilizzazione.

* Druckdifferenz Δp zwischen Ein- und Ausgang
* Pressure difference is Δp between input and output
* La différence de pression est Δp entre l'entrée et la sortie
* La differenza di pressione corrisponde al Δp tra ingresso e uscita

Achtung: Höhere Drücke auf Anfrage möglich.
Notice: Higher pressures are possible on request.
Remarque : des pressions supérieures sont possibles sur demande.
Nota: Pressioni superiori possibili su richiesta.

Code C

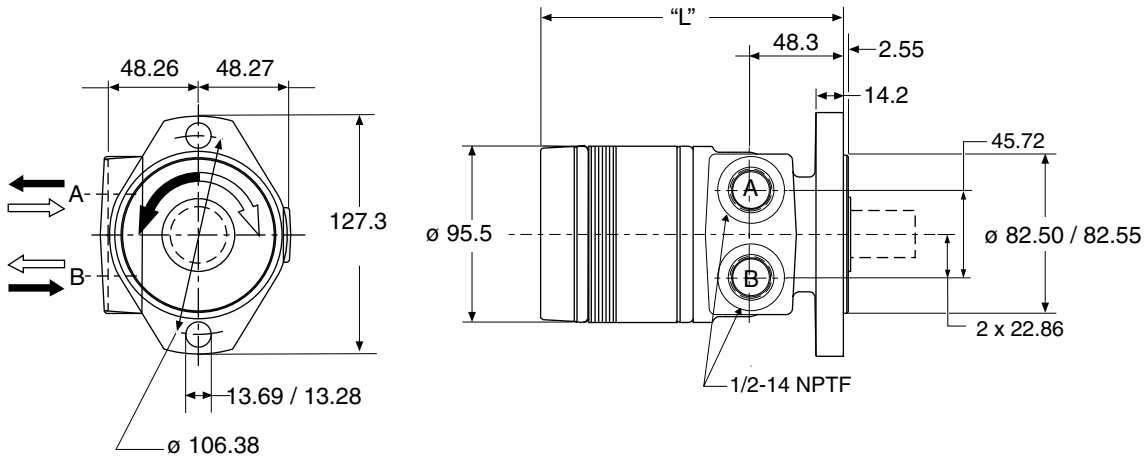

Code M

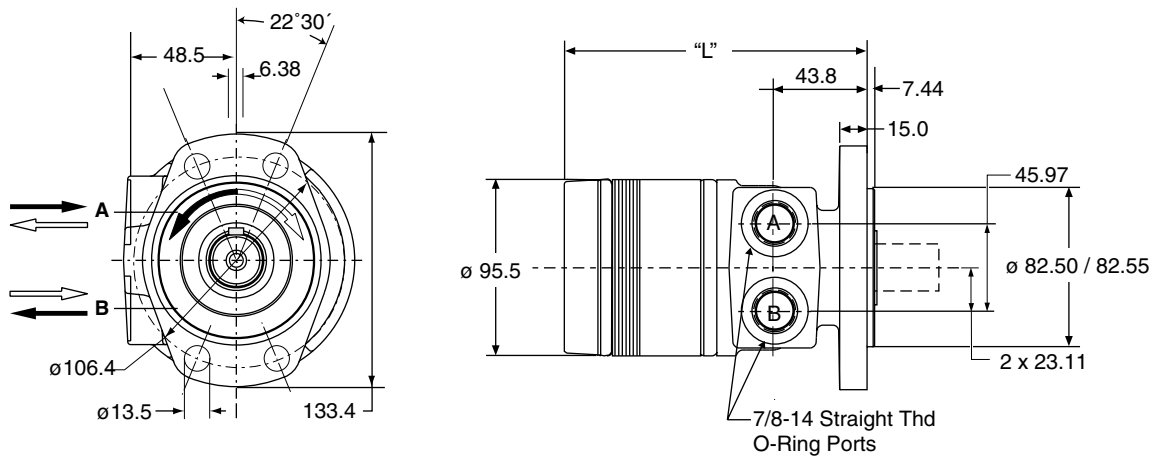

Code D

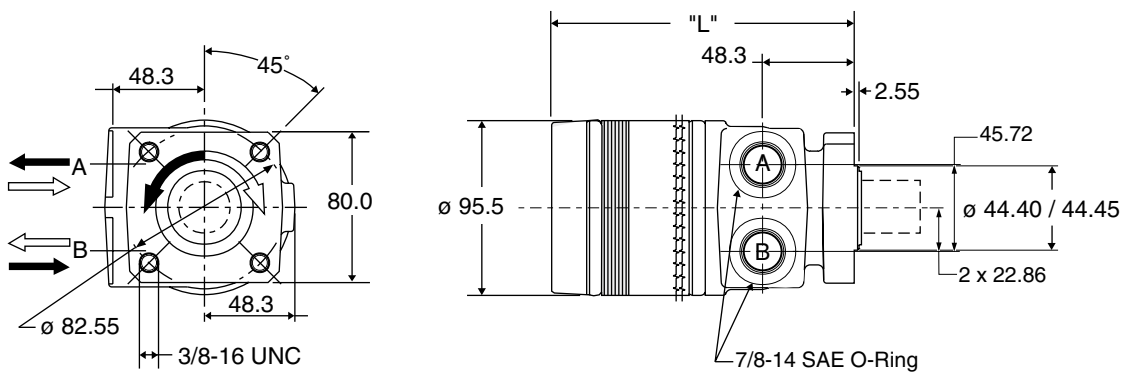

Gewicht / Weight Poids / Peso [kg]		TE36	TE45	TE50	TE65	TE80	TE100	TE130	TE165	TE195	TE230	TE260	TE295	TE330	TE365	TE390
		5,8	6,3	6,5	6,6	6,7	6,8	7,1	7,4	7,7	7,9	8,2	8,3	8,7	9,0	9,2
Code C	"L"[mm]	128	131	133	136	140	143	149	155	162	168	174	181	170	195	200
Code M, D	"L"[mm]	134	136	138	141	144	147	153	160	166	173	179	185	192	200	205

Code L

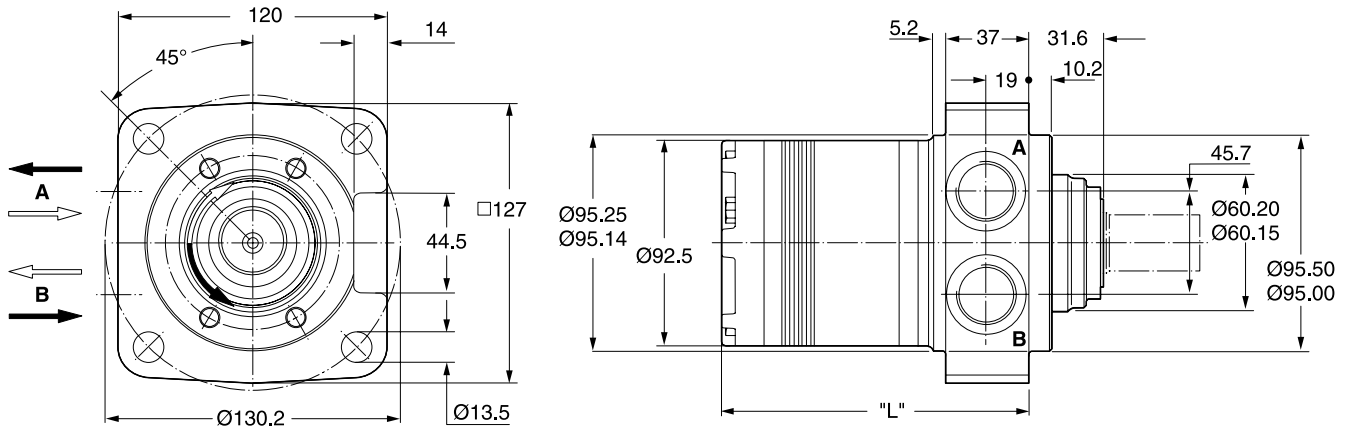

Code U

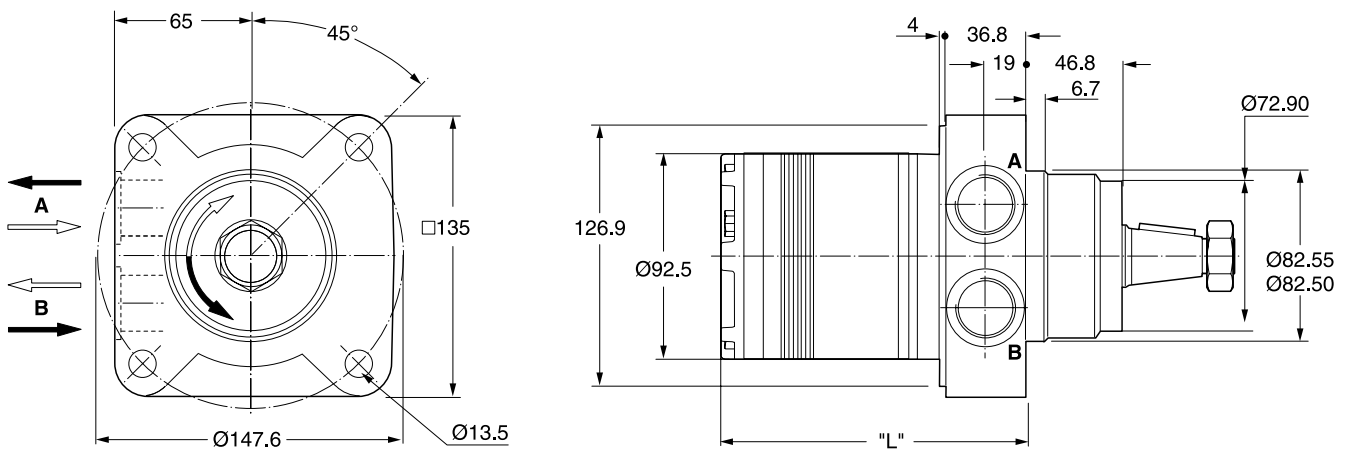

Gewicht / Weight	TJ36	TJ45	TJ50	TJ65	TJ80	TJ100	TJ130	TJ165	TJ195	TJ230	TJ260	TJ295	TJ330	TJ365	TJ390	
Poids / Peso [kg]	6,7	6,8	6,9	7,0	7,1	7,2	7,6	7,8	8,1	8,3	8,6	8,8	9,1	9,4	9,6	
Code L, U	"L"[mm]	103	106	109	112	115	118	124	131	137	143	150	156	162	171	175

Code W

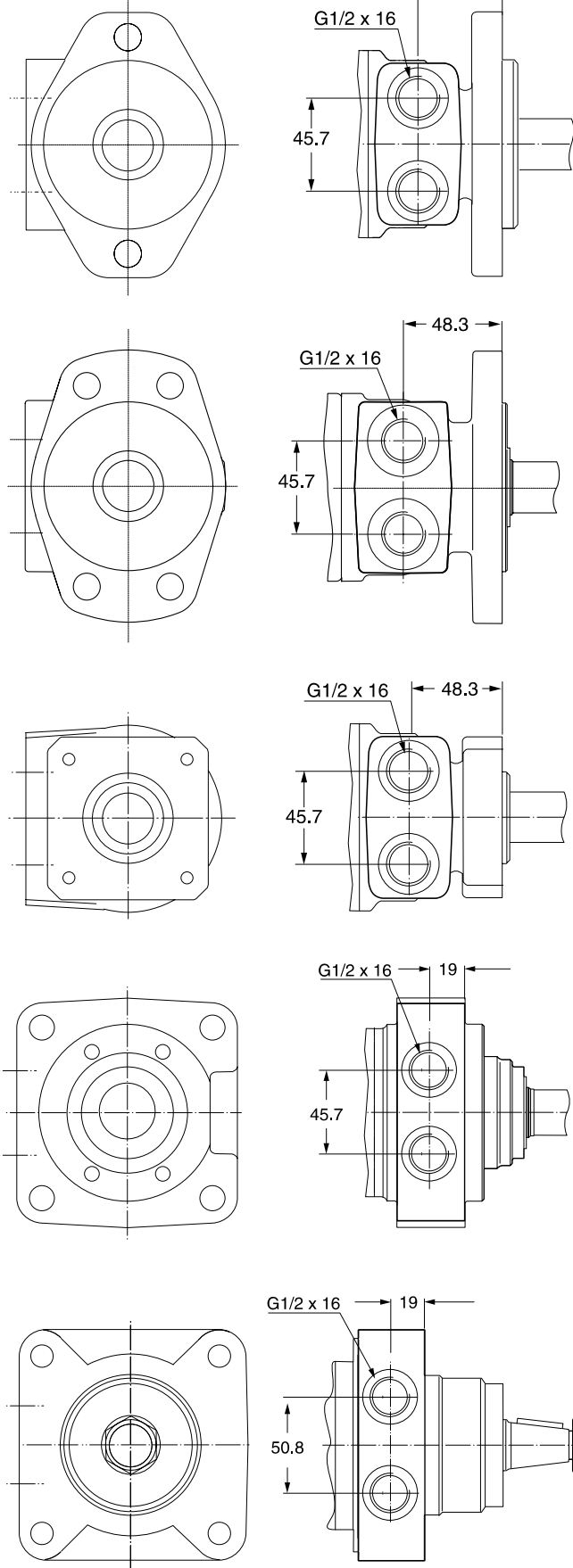

Code N

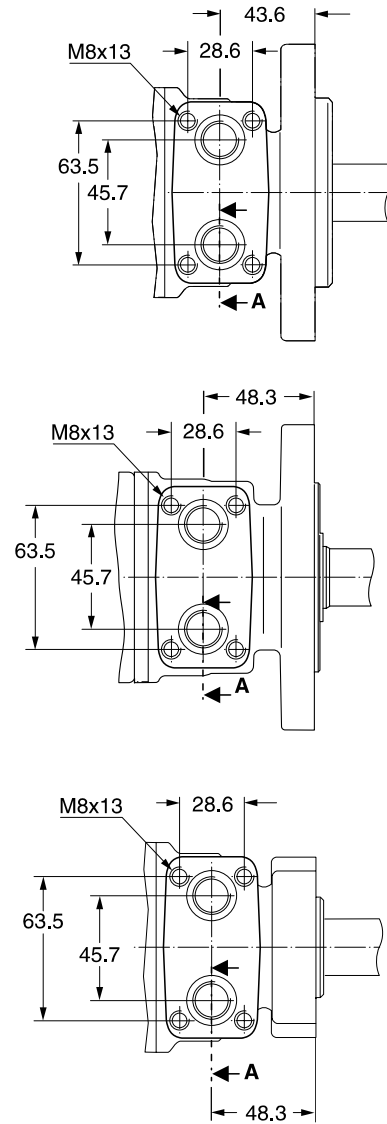

Section A

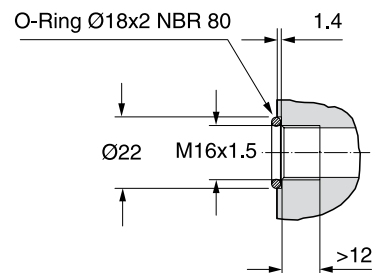

Zum Motor mit Universalanschluss werden 2 O-Ringe geliefert.

Motor with manifold mount is supplied with 2 O-rings.

Deux joints toriques sont livrés avec les moteurs au plan de raccordement universel.

Il blocchetto connessioni è corredato da 2 OR.

Code Y

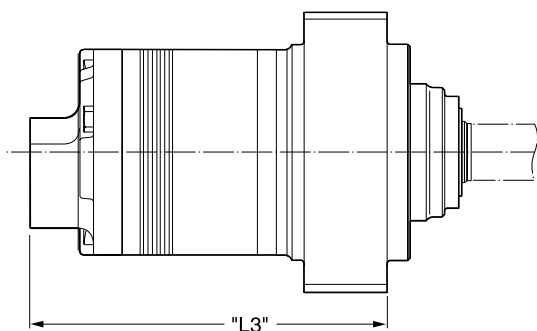
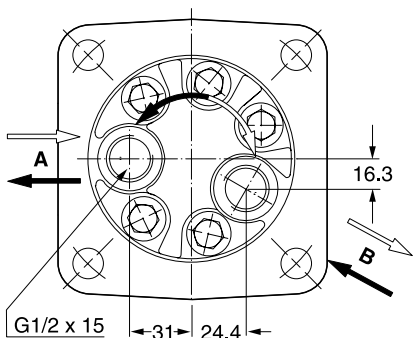
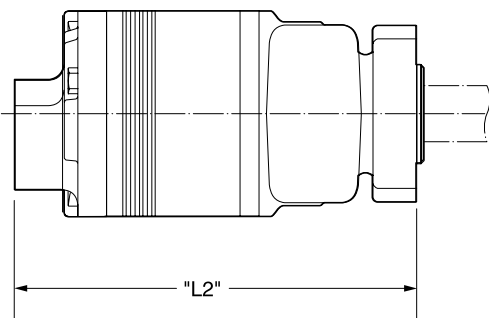
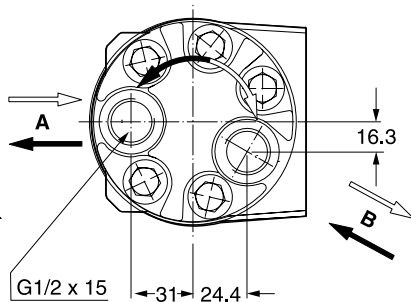
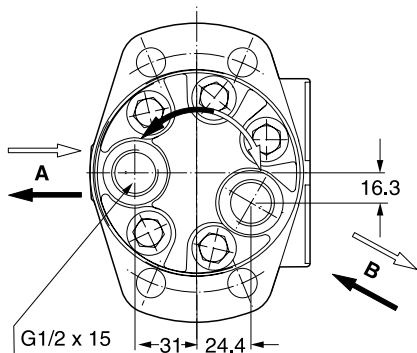
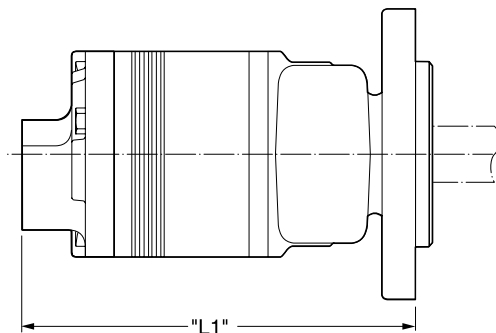
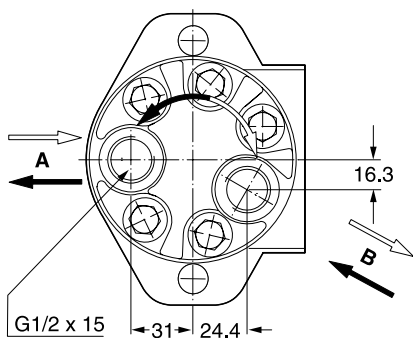

Gewicht / Weight	TE36	TE45	TE50	TE65	TE80	TE100	TE130	TE165	TE195	TE230	TE260	TE295	TE330	TE365	TE390
Poids / Peso [kg]	7,2	7,3	7,4	7,5	7,6	7,7	8,1	8,3	8,6	8,8	9,1	9,3	9,6	9,9	10,1
"L1"[mm]	151	152	154	157	160	164	170	177	183	189	196	202	208	215,5	221
Code Y "L2"[mm]	155	156	158	161	165	168	174	181	187	193	200	206	212	220	225
"L3"[mm]	127	128	130	132	136	139	145	152	158	164	171	177	183	191	196

Code 08

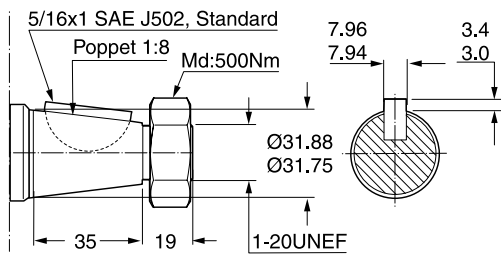

Code 10³⁾

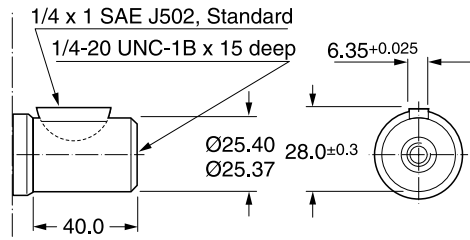

Code 12

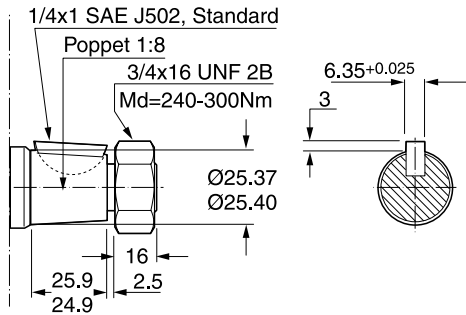

Code 25

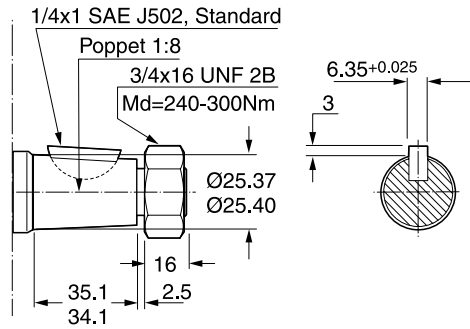

Code 26²⁾

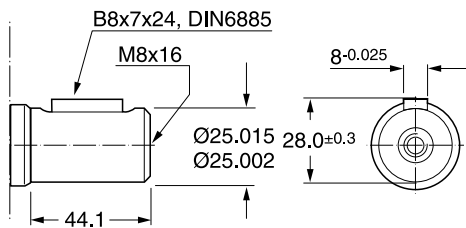

Code 41

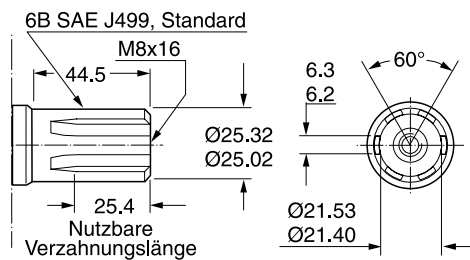

²⁾ **Code 69** = Rostfreie Ausführung
 Stainless steel version
 Version en acier inoxydable
 Versione in acciaio inossidabile
 230 Nm (2100lb in) Max. Drehmoment/
 Max Torque/ Couple maxi/ Coppia max

³⁾ **Code 70** = 25,4 mm - Rostfreie Ausführung
 25,4 mm - Stainless steel version
 25,4 mm - Version en acier inoxydable
 25,4 mm - Versione in acciaio inossidabile
 230 Nm (2100lb in) Max. Drehmoment/
 Max Torque/ Couple maxi/ Coppia max

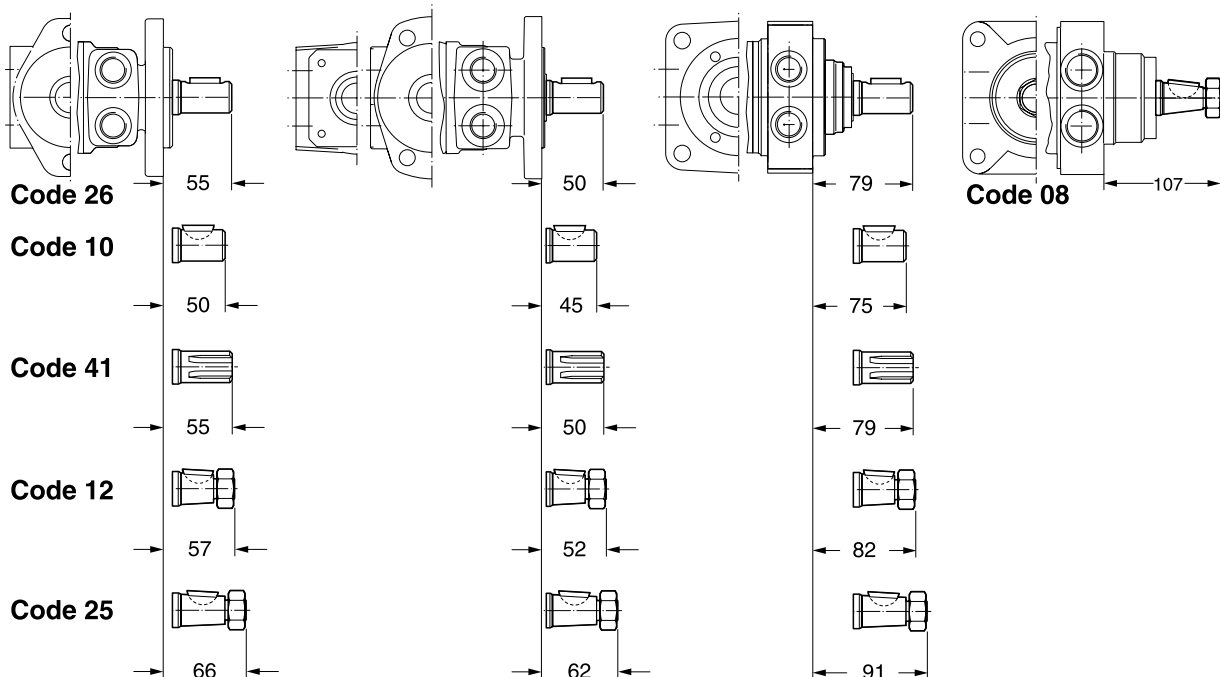

TE/TJ 36

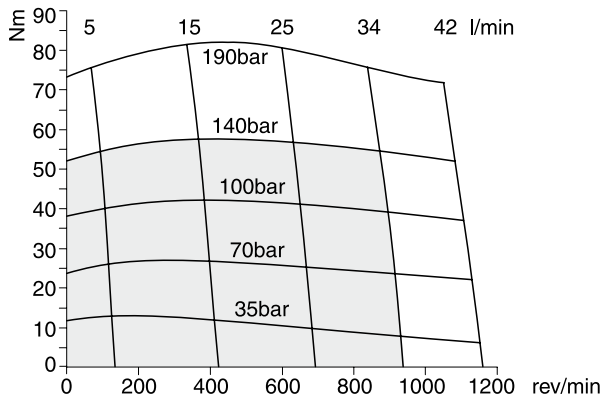

TE/TJ 45

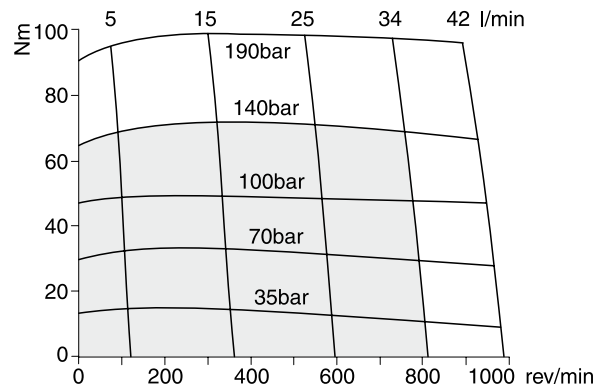

TE/TJ 50

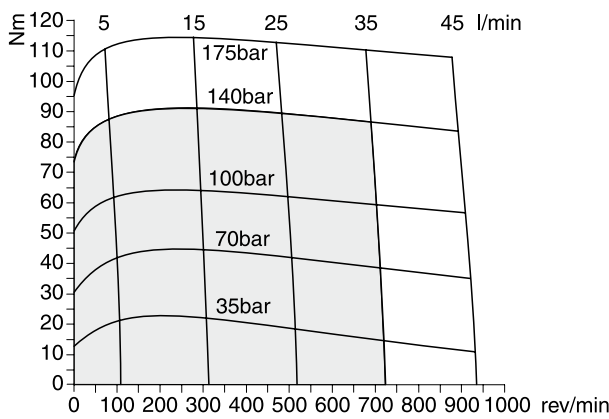

TE/TJ 65

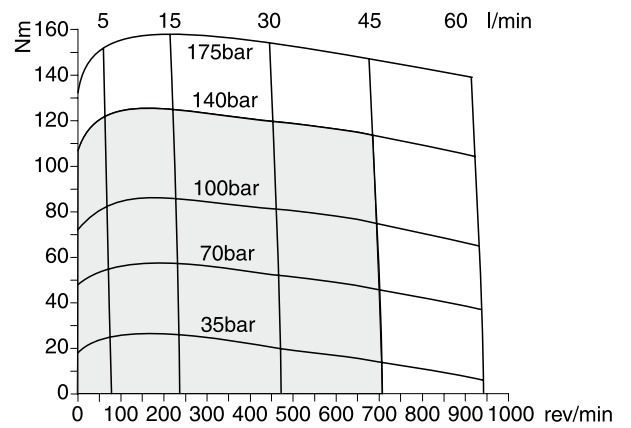

TE/TJ 80

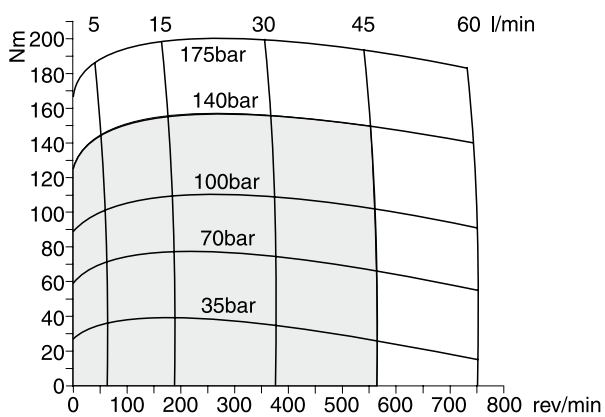

TE/TJ 100

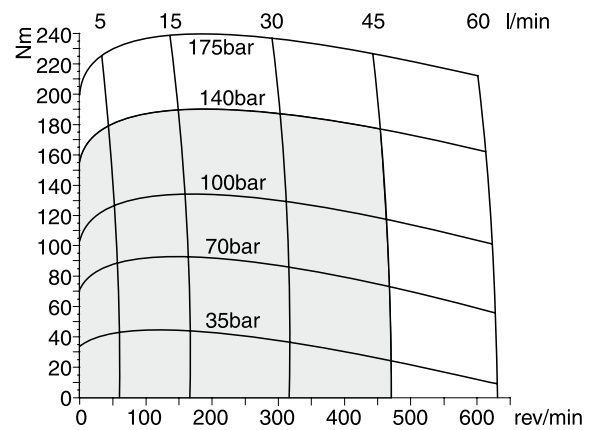

□ Cont.

□ Int.

int. =

Intermittierende Werte maximal 10% von jeder Betriebsminute.

Fonctionnement interm. 10% max. de chaque minute d'utilisation.

Intermittent operation rating applies to 10% of every minute.

Servizio intermittente 10% max di ogni minuto di utilizzazione.

TE/TJ 130

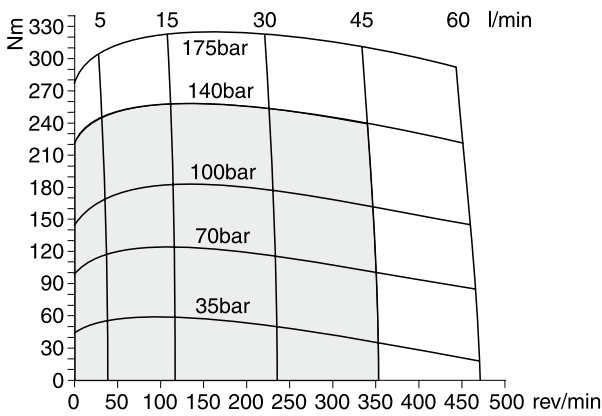

TE/TJ 165

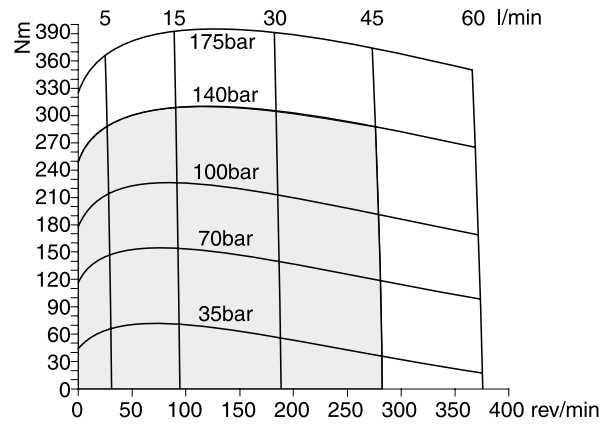

TE/TJ 195

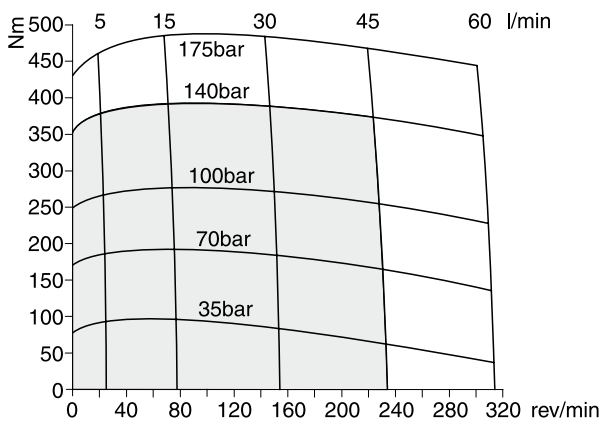

TE/TJ 230

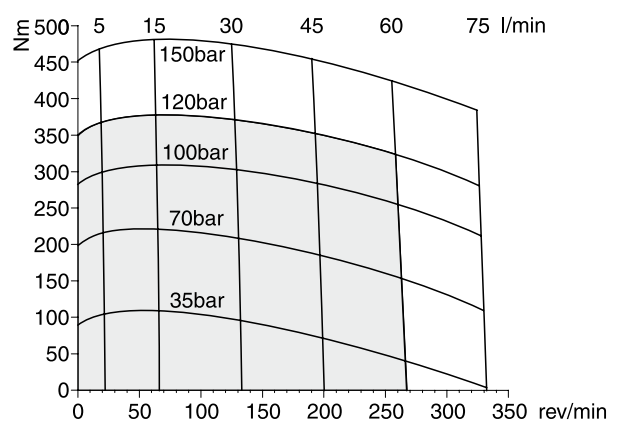

TE/TJ 260

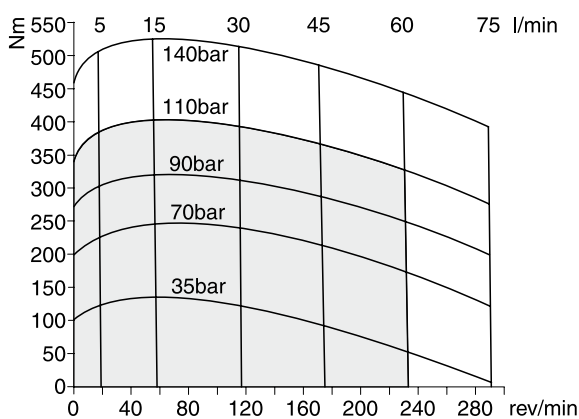

TE/TJ 295

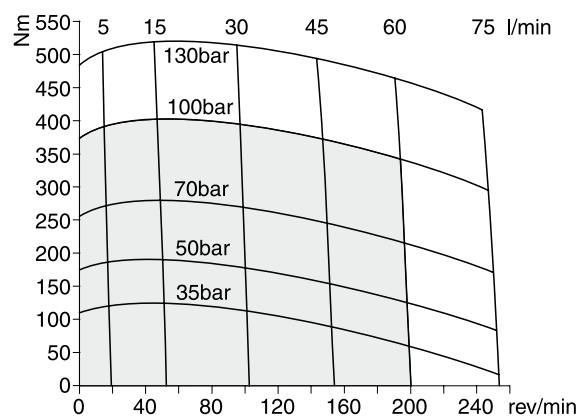

□ Cont.

□ Int.

int. =
 Intermittierende Werte maximal 10% von jeder Betriebsminute.
 Fonctionnement interm. 10% max. de chaque minute d'utilisation.
 Intermittent operation rating applies to 10% of every minute.
 Servizio intermittente 10% max di ogni minuto di utilizzazione.

TE/TJ 330

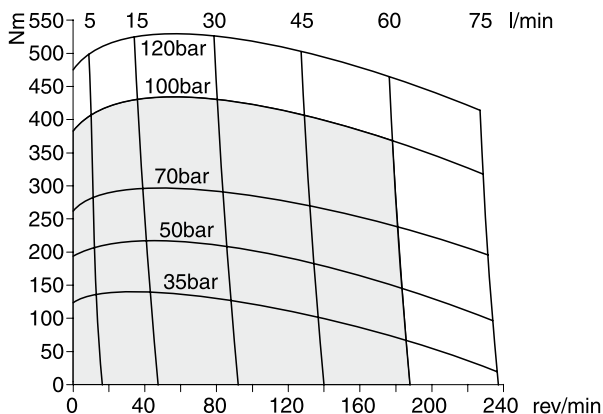

Beispiel / Example Series TE / TJ230

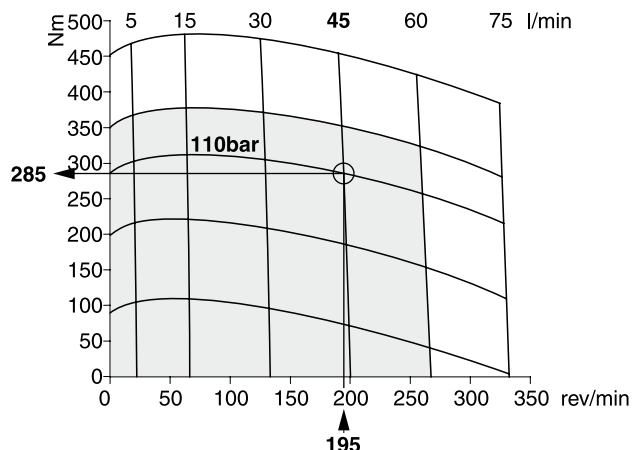

TE/TJ 365

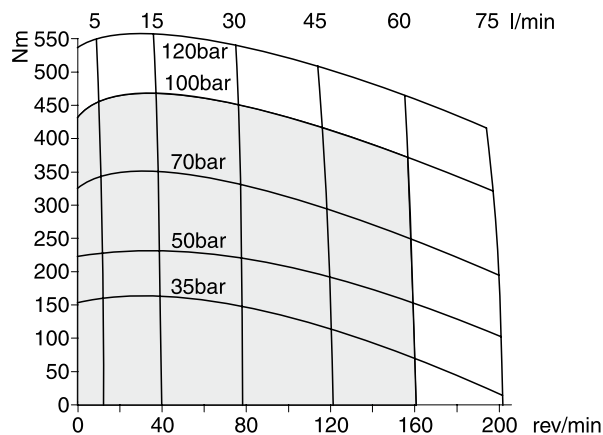

Md = 285 Nm V = 229.4 cm³/rev
 n = 195 rev/min Q = 45 l/min
 Δp = 110 bar

Volumetrischer Wirkungsgrad (η_{vol})
 Volumetric efficiency
 Rendement volumétrique
 Rendimento volumetrico

$$\eta_{vol} = \frac{n \cdot V}{Q \cdot 10^3} = \frac{195 \cdot 229.4}{45 \cdot 10^3}$$

$$\eta_{vol} = 0.99$$

Hydraulisch-mechanischer Wirkungsgrad (η_{hm})
 Hydraulic-mechanical efficiency
 Rendement hydro-mécanique
 Rendimento idro-meccanico

$$\eta_{hm} = \frac{Md \cdot 20 \cdot \pi}{\Delta p \cdot V} = \frac{285 \cdot 20 \cdot \pi}{110 \cdot 229.4}$$

$$\eta_{hm} = 0.71$$

Gesamtwirkungsgrad (η_{ges})
 Overall efficiency
 Rendement global
 Rendimento totale

$$\eta_{ges} = \eta_{vol} \cdot \eta_{hm} = 0.99 \cdot 0.71$$

$$\eta_{ges} = 0.70$$

TE/TJ 390

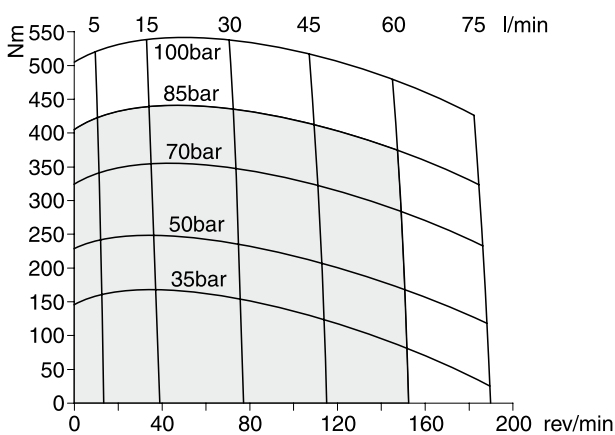

□ Cont. □ Int.

int. =
 Intermittierende Werte maximal 10% von jeder Betriebsminute.
 Fonctionnement interm. 10% max. de chaque minute d'utilisation.
 Intermittent operation rating applies to 10% of every minute.
 Servizio intermittente 10% max di ogni minuto di utilizzazione.

Leistung P (kW)
 Power P
 Puissance P
 Potenza P

$$P = \frac{Md \cdot n \cdot \pi}{10^4 \cdot 3} = \frac{285 \cdot 195 \cdot \pi}{10^4 \cdot 3}$$

$$P = 5.8 \text{ kW}$$

TE Code C/D

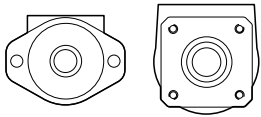

$$L_h = \frac{357300}{F_R \cdot \left(1.161 + \frac{L}{62\text{mm}}\right)^{3.3}} \cdot n$$

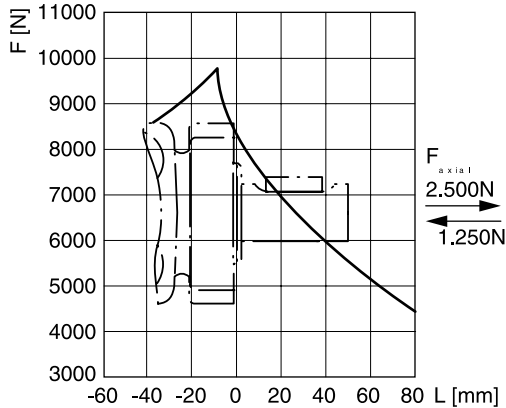

TE Code C

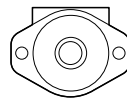

$$L_h = \frac{357300}{F_R \cdot \left(1.076 + \frac{L}{62\text{mm}}\right)^{3.3}} \cdot n$$

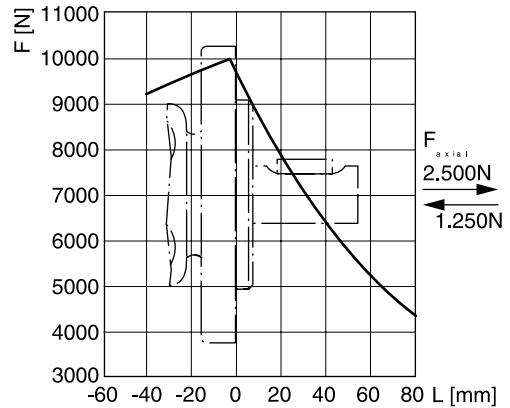

TE Code L

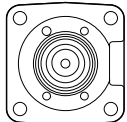

$$L_h = \frac{357300}{F_R \cdot \left(0.69 + \frac{L}{62\text{mm}}\right)^{3.3}} \cdot n$$

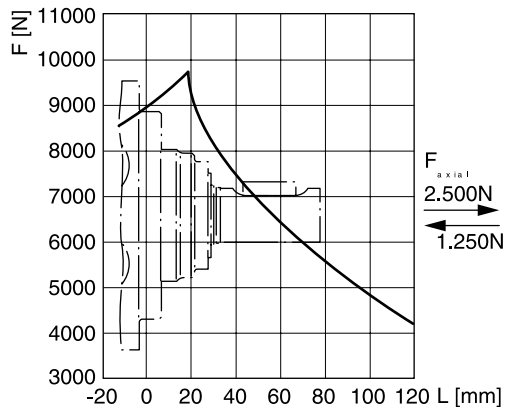

TJ Code U

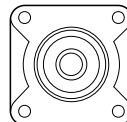

$$L_h = \frac{840000}{F_R \cdot \left(0.57 + \frac{L}{71\text{mm}}\right)^{3.3}} \cdot n$$

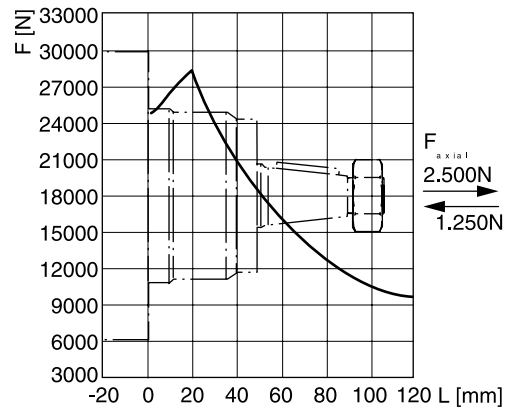

Die Lebensdauer der Radiallager (L_h in Stunden) lässt sich nach folgender Formel berechnen. Die Größe F_R ist durch die mechanische Festigkeit der Abtriebswelle begrenzt (siehe Diagramm). Das Maß "L" ist das Längenmaß vom Gehäuseflansch bis zum Angriffspunkt der Radialkraft F_R .

Life time (L_h in hours) of the radial bearings can be calculated with the following formula. The value F_R is limited by the mechanical strength of the shaft (see diagram). The measurement "L" is the length from the housing flange up to the point of impact of the radial force F_R .

La durée de vie des roulements radiaux (L_h en heures) peut être calculée par les formules suivantes. La grandeur F_R est limitée par les résistances mécaniques de l'arbre de sortie (voir diagramme). La cote "L" est la longueur entre la bride du carter jusqu'au point d'appui de l'effort radial F_R .

La durata dei cuscinetti (L_h in ore) può essere calcolata con la seguente formula. Il valore F_R è limitato dalla resistenza meccanica dell'albero (vedi diagramma). La quota "L" è la distanza tra la flangia del corpo ed il punto di applicazione della forza radiale F_R .

Vorstehende Formeln gelten für eine B10-Lebensdauer.
The preceding formulas are valid for a B10 duration of life.
Les formules précédentes sont valables pour une durée de vie B10.
Le formule precedenti sono valide per una durata della vita B10.

L_h = [h]
 L = [mm]
 n = [rev/min]

Ordering Code

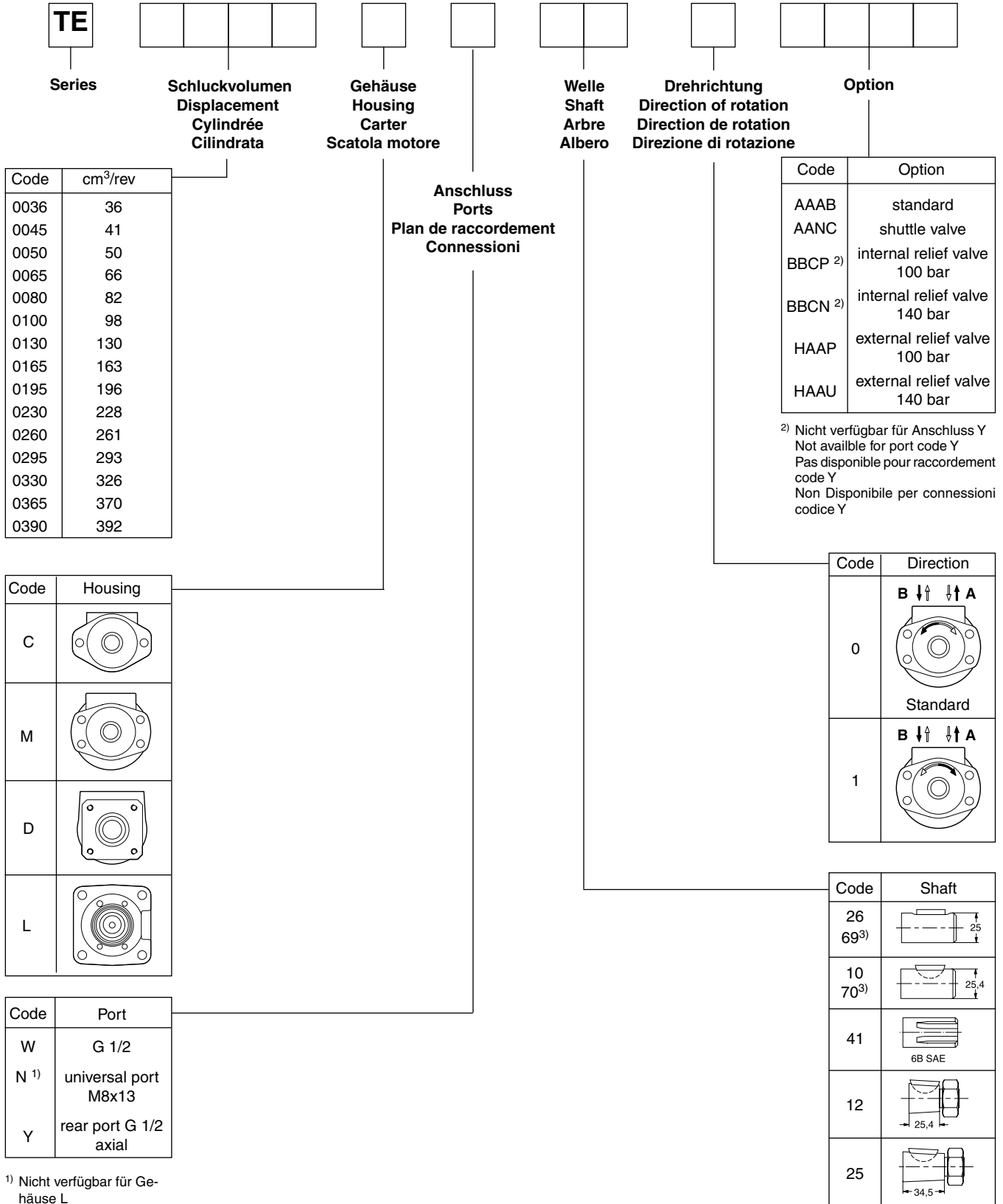

¹⁾ Nicht verfügbar für Gehäuse L
Not available for housing code L
Pas disponible pour carter code L
Non Disponibile per Alloggiamento codice L

³⁾ 230 Nm (2100lb in) Max. Drehmoment/
Max Torque/ Couple maxi/ Coppia max

Ordering Code

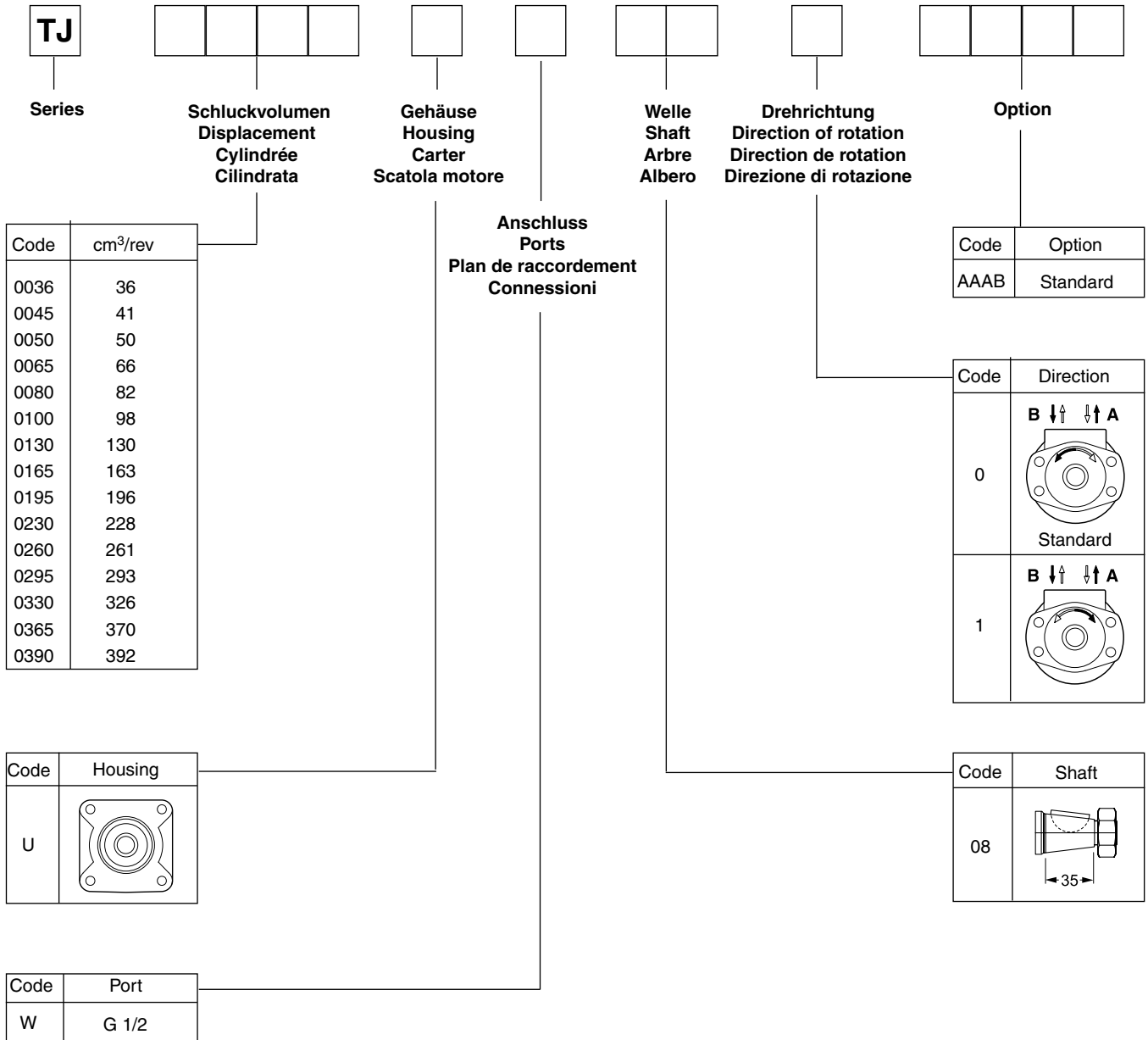

Schockventil / Relief valve / Soupape sécurité / Regolatrice pressione

Extern / external

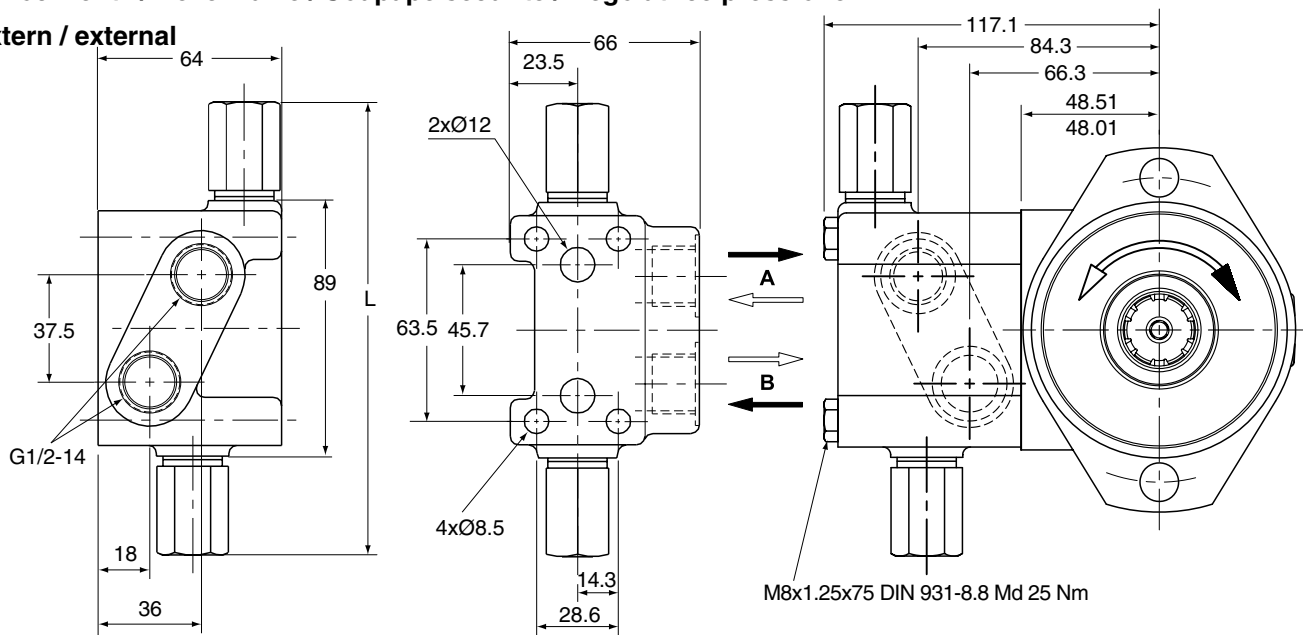

Bestellschlüssel / Ordering code / Système de commande / Sistema di ordinazione

Option code	Shift pressure	Single valve	Single part order no.	Option code	Length "L"
HAAP	100 bar	Zubehör / Fixtures 4 x M8 x 75mm 2 x O Ring	410017-100	HAAP	158 mm
HAAU	140 bar		410017-140	HAAU	158 mm

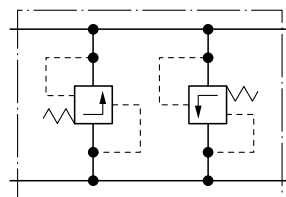

Intern / internal

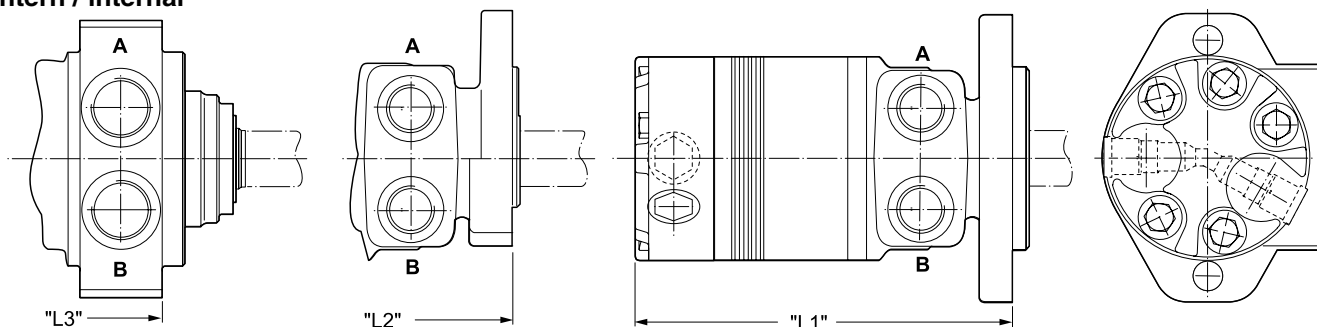

Bestellschlüssel / Ordering code / Système de commande / Sistema di ordinazione

Option code	Shift pressure
BBCP	100 bar
BBCN	140 bar

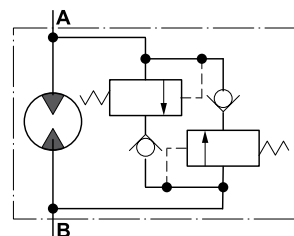

Ventilcurve auf Anfrage
 Valve curve available on request
 La courbe caractéristique de la vanne est disponible sur demande
 Curva della valvola disponibile su richiesta

Gewicht / Weight	TE36	TE45	TE50	TE65	TE80	TE100	TE130	TE165	TE195	TE230	TE260	TE295	TE330	TE365	TE390
Poids / Peso [kg]	7.8	7.9	8.0	8.1	8.2	8.3	8.6	8.9	9.2	9.4	9.7	9.8	10.2	10.5	10.7
Code	"L1" [mm]	157	159.8	161.8	164.8	168.2	171.2	177.5	183.9	190.2	196.6	202.9	209.3	215.6	223.8
	"L2" [mm]	163	164.4	166.4	169.4	172.7	175.7	182.1	188.5	194.8	201.2	207.5	213.9	220.2	228.2
	"L3" [mm]	134	135.5	137.5	140.5	143.5	146.7	153.2	159.5	165.8	172.3	178.6	185.0	191.3	199.4

Code AANC

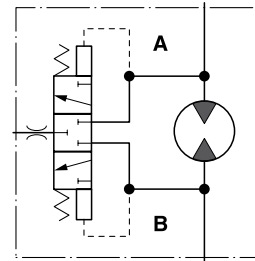
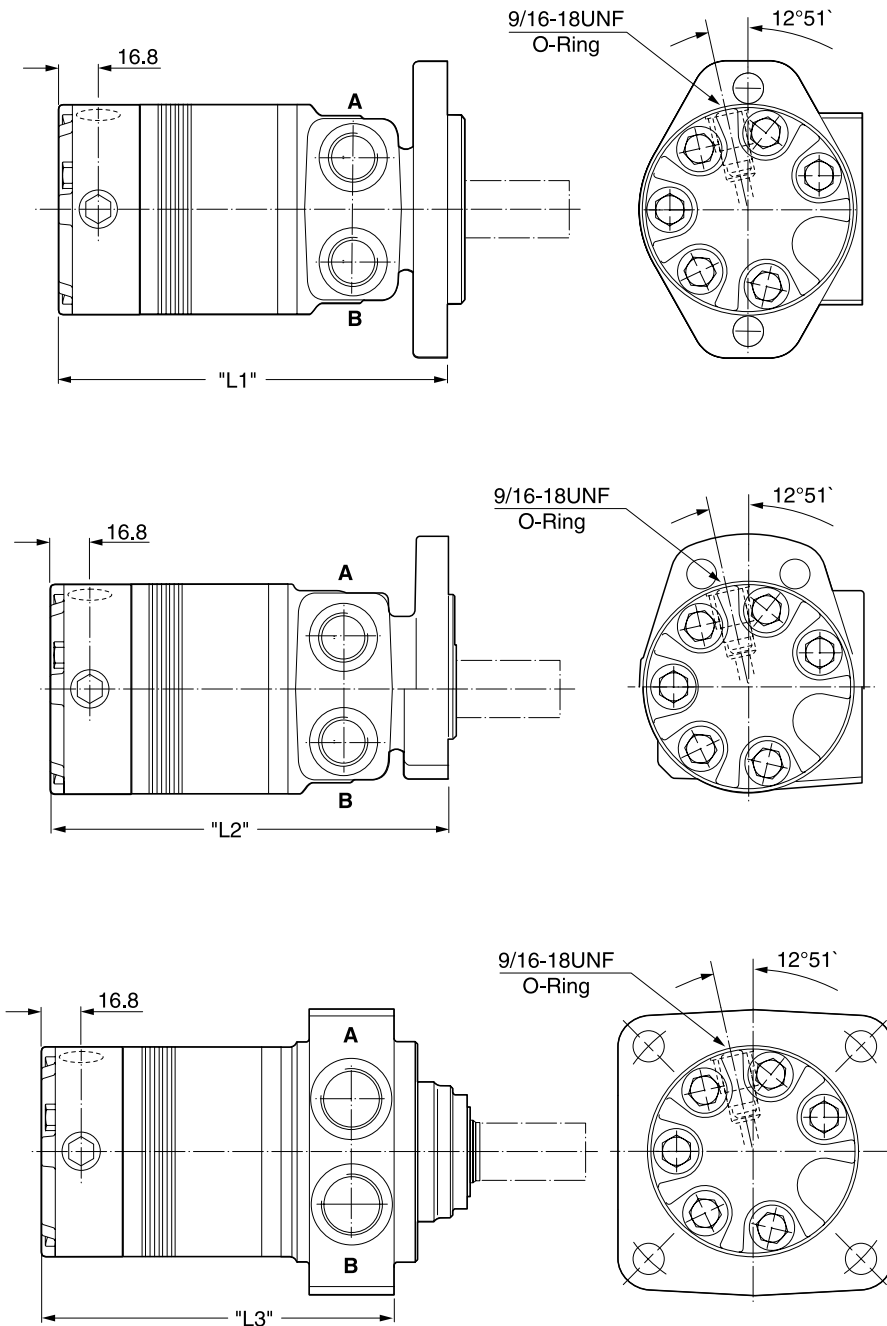

Q=5 l p=9 bar $\dot{v}=39 \text{ mm}^2/\text{s}$

Spülventil für geschlossene Systeme zur Rückführung einer definierten Menge des Niederdrucköls in den Tank zur Abkühlung innerhalb des Selben Kreislaufs.

Hot oil shuttle valve allows for diverting of low pressure oil in closed loop applications to be returned to tank, cooler or filter for cooling in the same circuit.

Valve de rinçage pour systèmes fermes pour le retour d'un volume déterminé de fluide basse pression vers le réservoir, un refroidisseur ou un filtre de réfrigération, dans le même circuit.

Una valvola scambiatrice di calore permette di deviare olio a bassa pressione direttamente al serbatoio o allo scambiatore de calore consentendo, nelle applicazioni a circuito chiuso, un miglior raffreddamento dell'olio.

Gewicht / Weight	TE36	TE45	TE50	TE65	TE80	TE100	TE130	TE165	TE195	TE230	TE260	TE295	TE330	TE365	TE390	
Poids / Peso [kg]	7.4	7.5	7.6	7.7	7.8	7.9	8.3	8.5	8.8	9.0	9.3	9.5	9.8	10.0	10.3	
Code	"L1" [mm]	149	150	152	155	158	161	168	174	180	187	193	199	206	214	219
	"L2" [mm]	153	154	156	159	162	166	172	178	184	191	197	203	210	218	222
	"L3" [mm]	124	125	127	130	134	137	143	150	156	162	168	175	181	189	194

Option FSAB

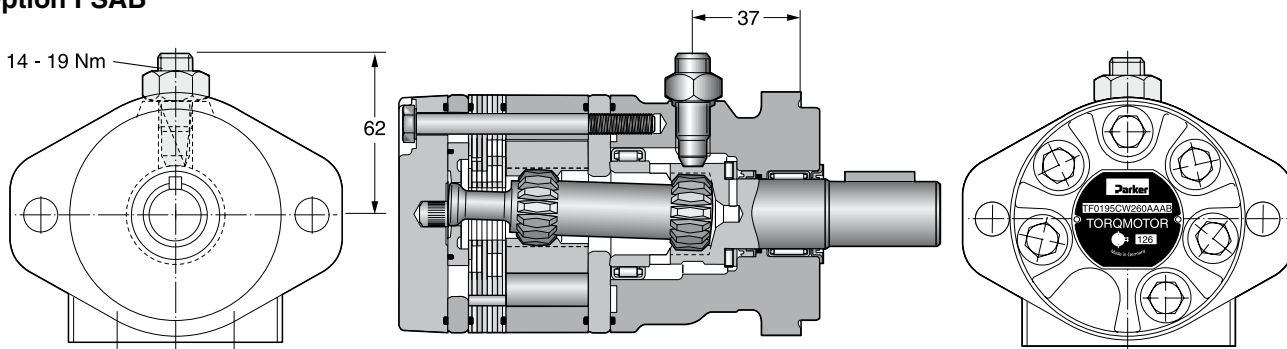

Der Sensor ist gegen Verpolung der Versorgungsspannung, jedoch nicht gegen Kurzschluss geschützt.

Le capteur est protégé contre l'inversion de polarité de la tension d'alimentation, mais pas contre les courts circuits.

The sensor has reverse polarity protection but no short circuit protection.

Il sensore è protetto contro l'inversione della polarità della tensione di alimentazione, ma non contro il corto circuito.

Ordering code

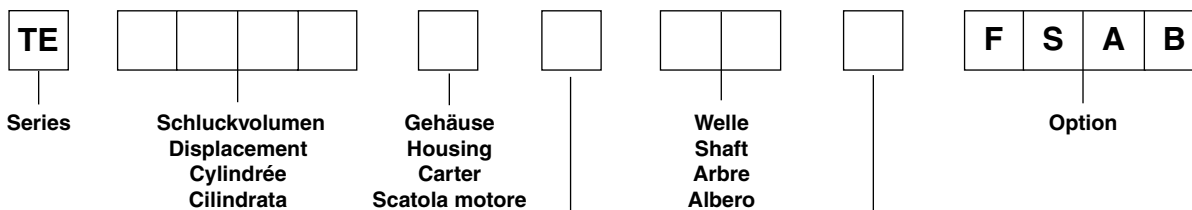

Code	cm ³ /rev
0036	36
0045	41
0050	50
0065	66
0080	82
0100	98
0130	130
0165	163
0195	196
0230	228
0260	261
0295	293
0330	326
0365	370
0390	392

Code	Housing
C	

**Anschluss
 Ports
 Plan de raccordement
 Connessioni**

Code	Port
W	G 1/2
N	universal port M8x13
Y	rear port G 1/2 axial

**Drehrichtung
 Direction of rotation
 Direzione di rotazione**

Code	Direction
0	 Standard
1	

Code	Shaft
26	 25
10	 25,4
41	 6B SAE

- **Langsamlaufender Gerotor-Motor**
 - **Spezielle Orbital-Steuerung**
Geringe interne Leckage
Hoher volumetrischer Wirkungsgrad
 - **Rollen im Rotorsatz**
Reduzierte Reibung
Lange Lebensdauer
 - **Patentierter Hochdruckwellendichtung**
Keine Leckölleitung
Keine Rückschlagventile
 - **Vielzahl von Varianten**
Großer Einsatzbereich
- **Low Speed Gerotor Motor**
 - **Zero leak commutation valve**
For greater, more consistent volumetric efficiency
 - **Roller vane rotor set**
Reduces friction and internal leakage
Maintaining efficiency throughout the life of the motor
 - **A patented high-pressure shaft seal**
No check valves needed
No extra plumbing
 - **Wide choice of displacement range, flange and shaft options**
Greater efficiency in systems design to suit your application
- **Moteur lent système Gerotor**
 - **Une distribution orbitale particulière assure**
fuites internes minimales
rendements volumétriques élevés
 - **Le rotor à rouleaux**
réduit les frottements
augmente la durée de vie
 - **Par l'utilisation de joints d'arbre haute pression brevetés**
pas de conduite de drainage
pas de clapets anti-retour
 - **Grâce à de nombreuses variantes**
larges domaines d'application
- **Motore orbitale a bassa velocità**
 - **Una particolare distribuzione orbitale assicura**
trafilamento ridotto
elevato rendimento volumetrico
 - **Con lo statore a rullini**
si riduce l'attrito interno
si mantiene nel tempo l'efficienza del motore
 - **Una guarnizione di tenuta ad alta pressione brevettata elimina la necessità**
di una linea di drenaggio esterna
e di valvole di non ritorno
 - **Un'ampia gamma di cilindrata, flange ed alberi**
consentono scelte adeguate ad ogni esigenza costruttiva

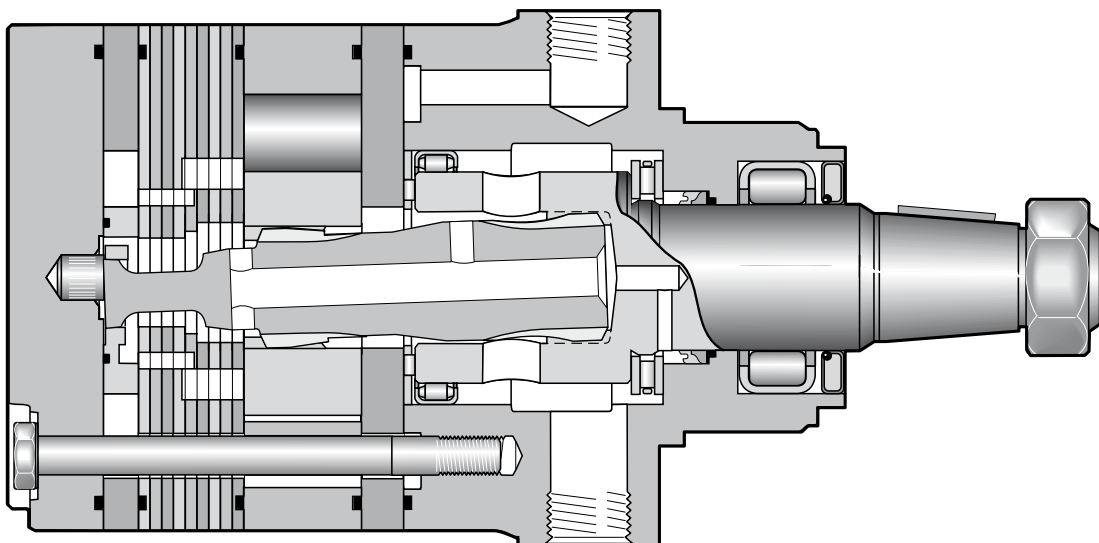

Performance

Drehzahl Speed Vitesse de rotation Velocità di rotazione	5...750 rev/min
Schluckstrom Oil flow Débit d'huile Portata	max. 100 l/min
Eingangsdruck Supply pressure Pression entrée Pressione in entrata	max. 300 bar
Drehmoment Torque Couple Coppia	max. 900 Nm
Seitenlast Side load Charges latérales Carico radiale	max. 16.000 N

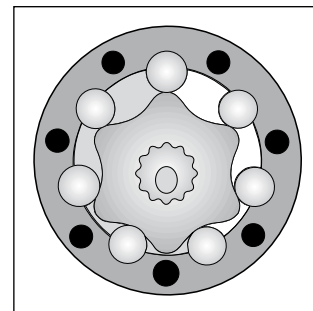
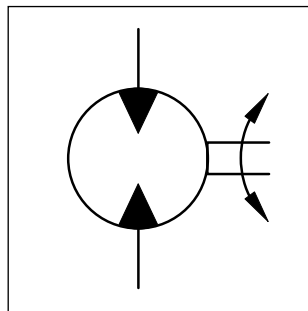

Motor series TF	Geom. Schluckvolumen Geometric displacement Cylindrée Cilindrata	Max. Drehzahl Max. speed Vitesse de rotation maxi Velocità di rotazione max	Max. Schluckstrom Max. oil flow Débit d'huile max Portata max	Max. Druckdifferenz * Chute de pression * Caduta di pressione *	Max. Eingangsdruck Max. supply pressure Pression maxi entrée Pressione max in entrata	Max. Drehmoment Max. torque Couple maxi Coppia max	Max. Leistungsgabe Max. performance Puissance de sortie maxi Potenza meccanica max	Min. Anlaufmoment Min. starting torque Couple min. fourni au démarrage Coppia min. di spunto
	[cm ³ /U] [cm ³ /rev]	cont / int [U/min] [rev/min]	cont / int [l/min]	cont / int [bar]	max [bar]	cont / int [Nm]	cont / int [KW]	cont / int [Nm]
TF 80	81	550/730	45/60	210/280	300	220/295	22	172/236
TF 100	100	600/750	60/75	160/240	300	200/320	25	168/252
TF 130	128	470/580	60/75	140/210	300	230/360	22	192/280
TF 140	141	370/530	60/75	140/210	300	250/390	22	197/308
TF 170	169	355/440	60/75	140/210	300	320/490	23	264/388
TF 195	197	300/380	60/75	140/210	300	365/560	22	304/448
TF 240	238	320/420	75/100	140/210	300	430/670	28	368/548
TF 280	280	270/350	75/100	140/210	300	550/800	28	440/672
TF 360	364	200/260	75/100	130/190	300	590/910	24	517/779
TF 405	405	170/230	75/100	130/175	300	660/920	22	575/789
TF 475	477	150/200	75/100	115/140	300	680/850	17	603/740

int. =

Intermittierende Werte maximal: 10% von jeder Betriebsminute.

Intermittent operation rating applies to 10% of every minute.

Fonctionnement interm.: 10% max. de chaque minute d'utilisation.

Servizio intermittente: 10% max di ogni minuto di utilizzazione.

- * Druckdifferenz Δp zwischen Ein- und Ausgang
- * Pressure difference is Δp between input and output
- * La différence de pression est Δp entre l'entrée et la sortie
- * La differenza di pressione corrisponde al Δp tra ingresso e uscita

Achtung: Höhere Drücke auf Anfrage möglich.

Notice: Higher pressures are possible on request.

Remarque : des pressions supérieures sont possibles sur demande.

Nota: Pressioni superiori possibili su richiesta.



Code E

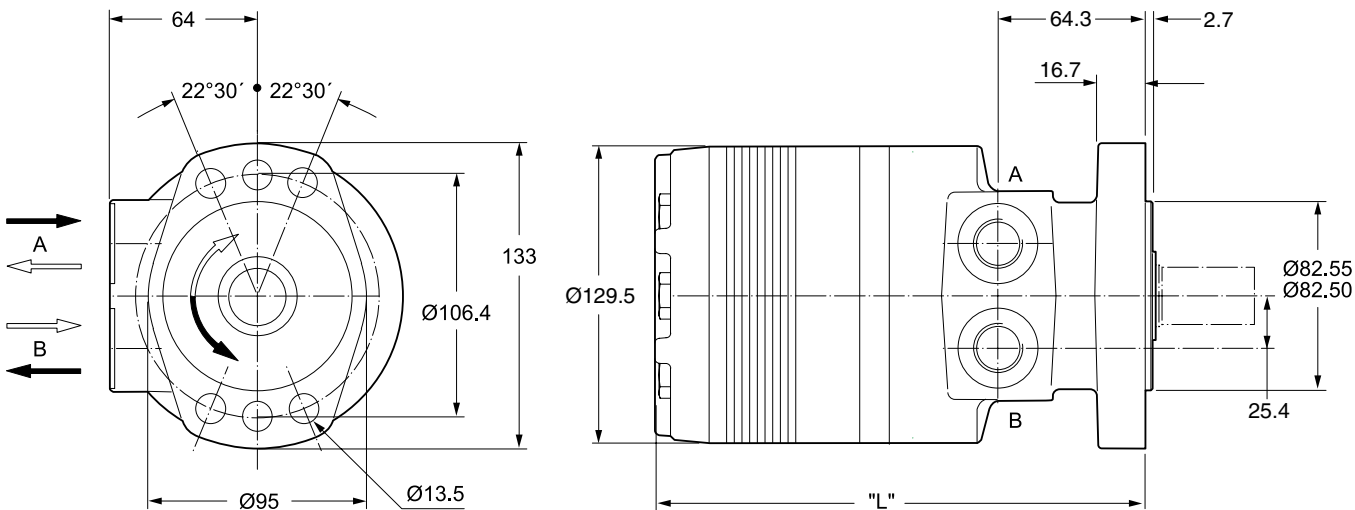

Code M

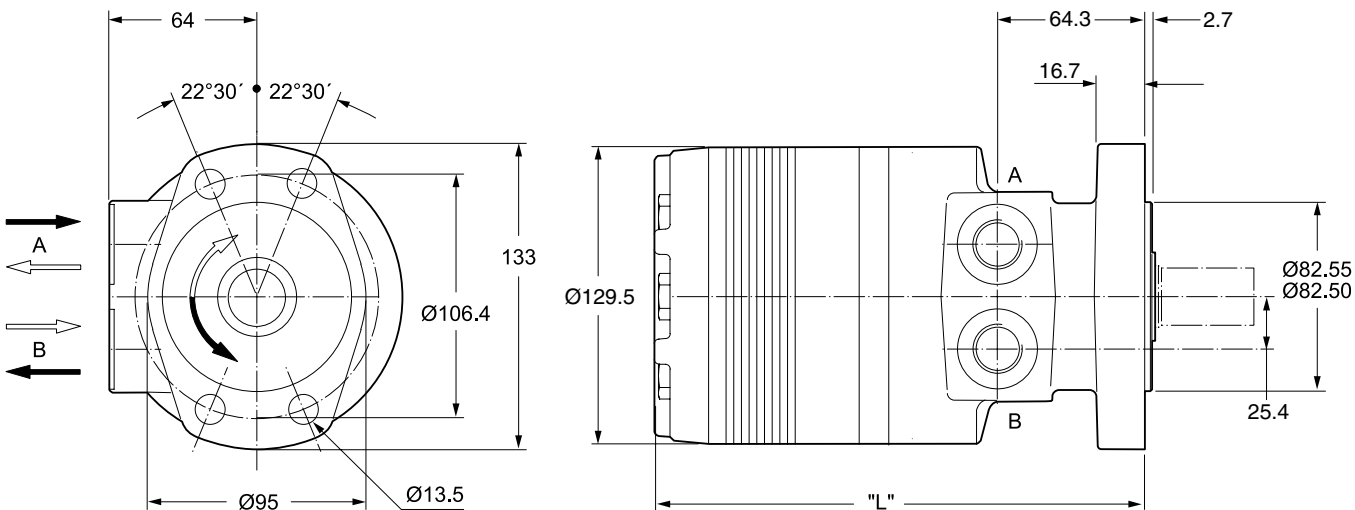

Gewicht / Weight		TF80	TF100	TF130	TF140	TF170	TF195	TF240	TF280	TF360	TF405	TF475
Poids / Peso [kg]		13.6	13.7	13.9	14.0	14.2	14.7	15.0	15.5	16.0	16.5	17.5
Code E	"L" [mm]	186	186	189	191	194	197	202	206	215	220	229
Code M	"L" [mm]	191	191	194	196	199	202	207	212	220	225	234

Code H

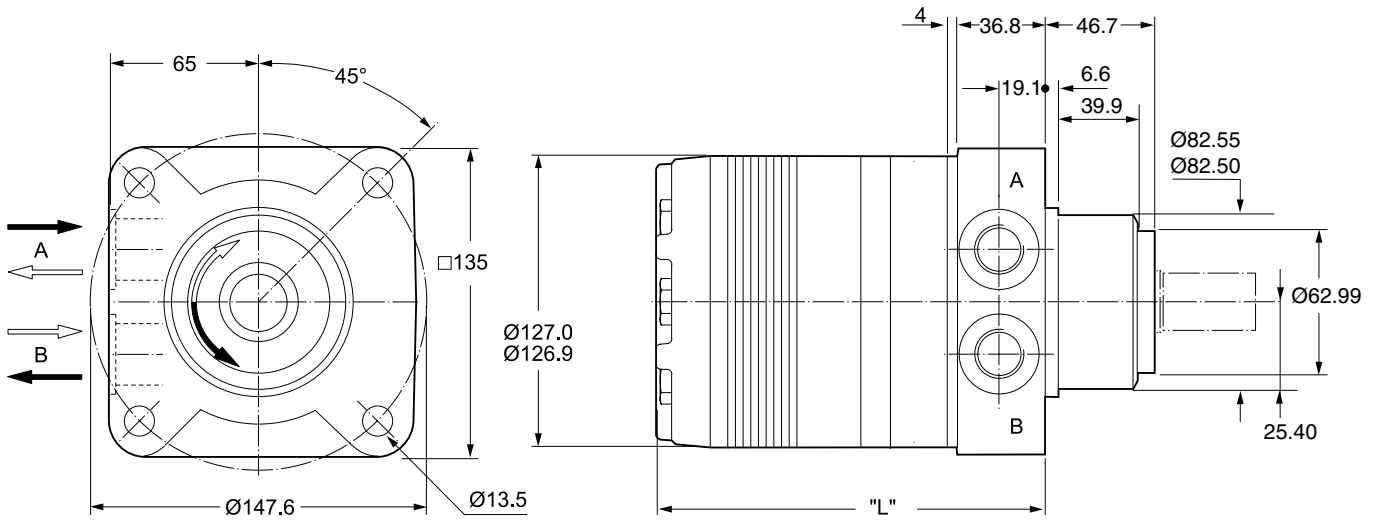

Code V

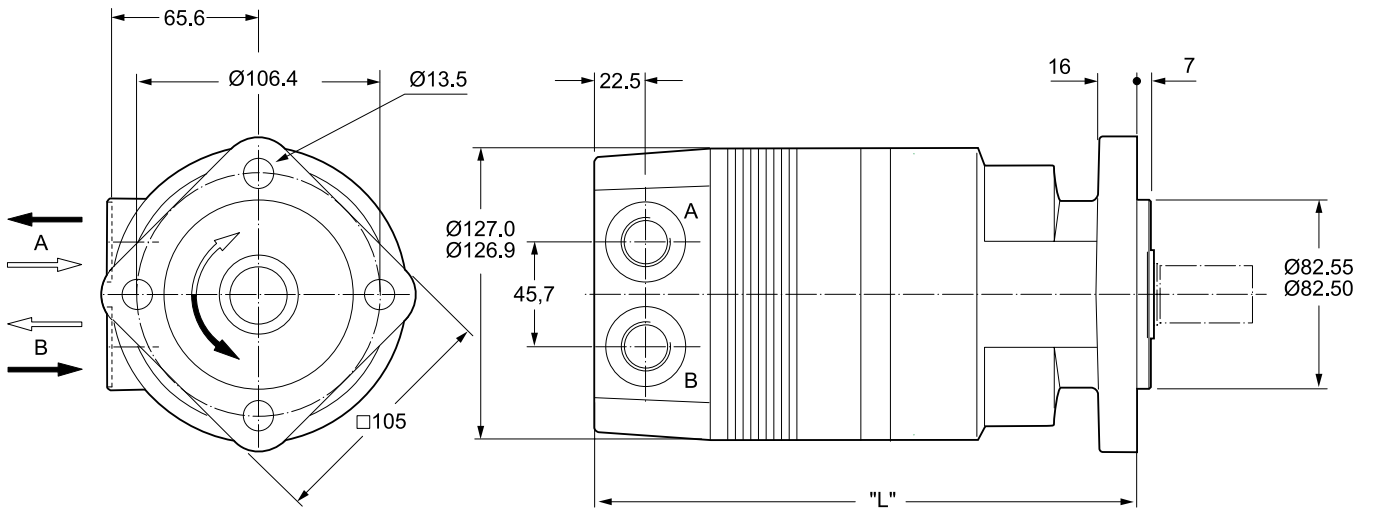

Gewicht / Weight	TF80	TF100	TF130	TF140	TF170	TF195	TF240	TF280	TF360	TF405	TF475
Poids / Peso [kg]	14.0	14.0	14.2	14.3	14.6	14.9	15.3	15.6	16.3	17.0	17.5
Code H "L" [mm]	146	146	149	151	154	157	162	167	175	180	189
Code V "L" [mm]	213	213	216	218	221	224	229	233	242	247	256

Code W

G1/2 x 15

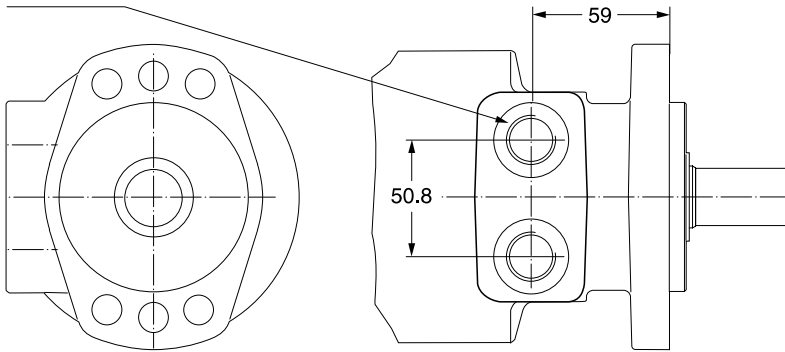

Code N

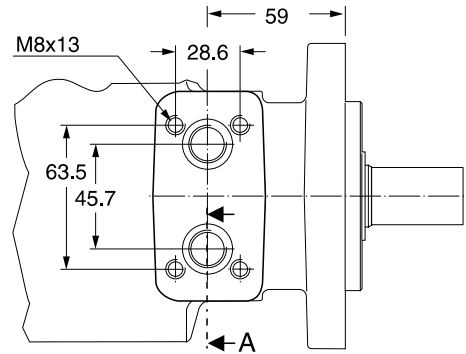

Code W

G1/2 x 15

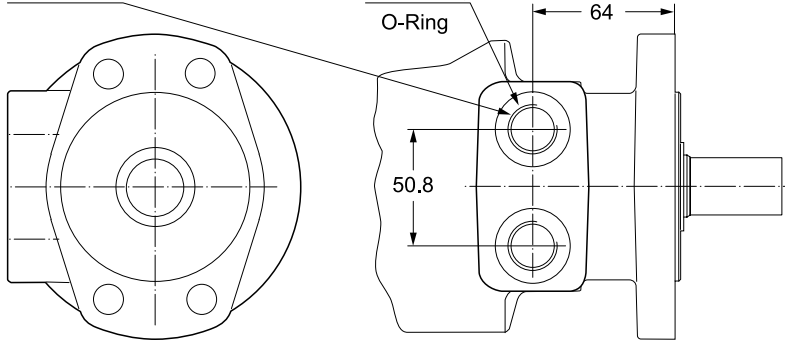

Code V

7/8-14UNF,
 O-Ring

Code N

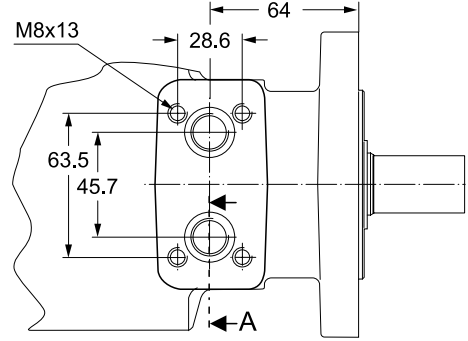

Code W

G1/2 x 15

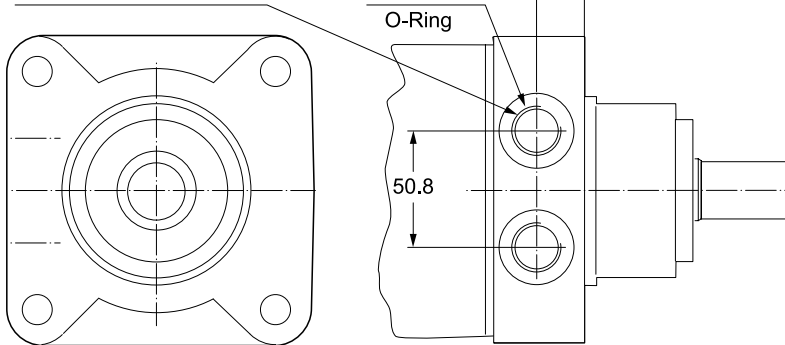

Code V

7/8-14UNF,
 O-Ring

Code K

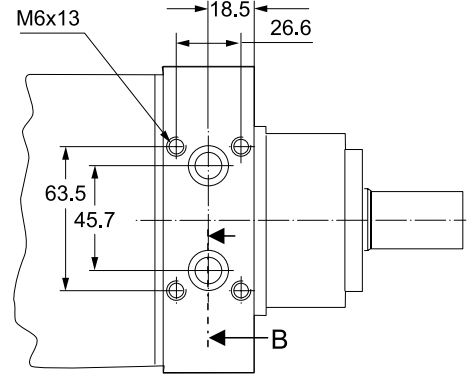

Section A

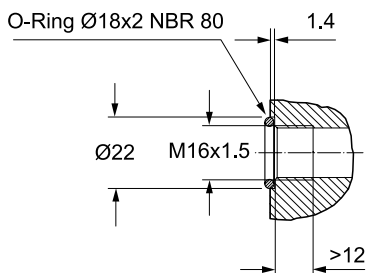

Section B

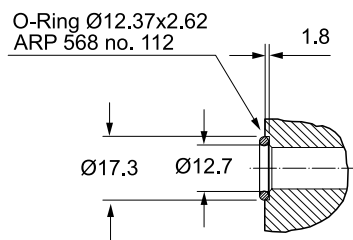

Zum Motor mit Universalanschluss werden 2 O-Ringe geliefert.

Motor with manifold mount is supplied with 2 O-rings.

Deux joints toriques sont livrés avec les moteurs au plan de raccordement universel.

Il blocchetto connessioni è corredato da 2 OR.

Code B 7/8-14UNF Code X G 1/2

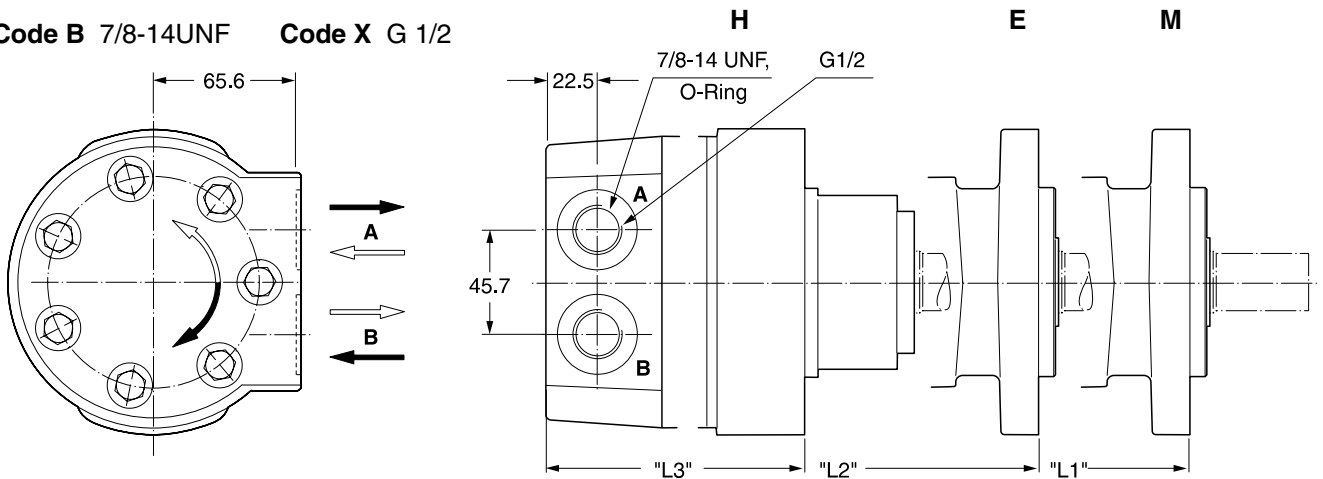

Code L

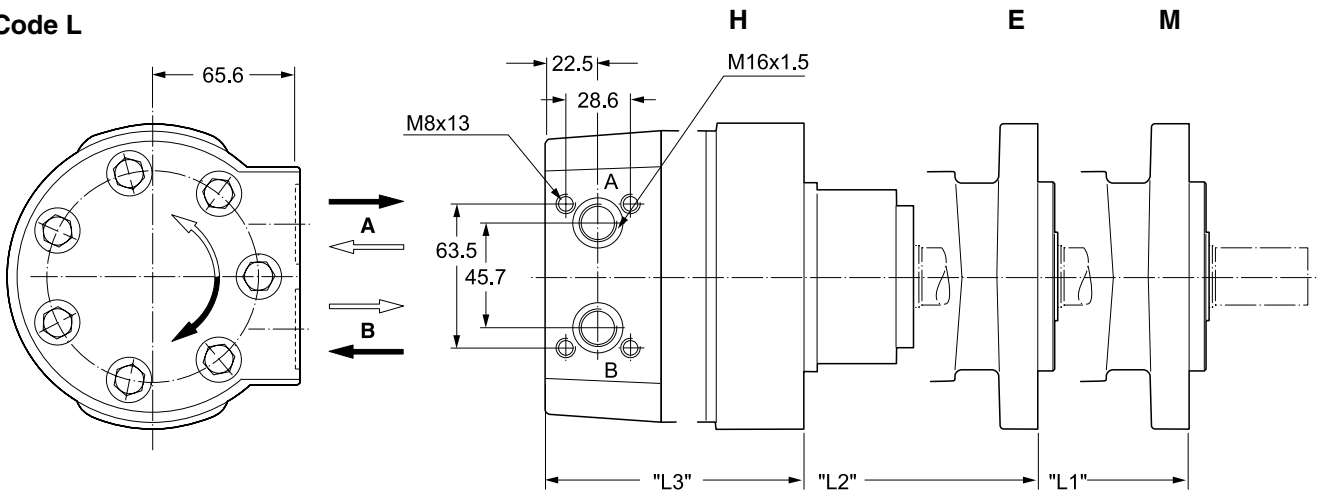

Code A 7/8-14UNF Code Y G 1/2

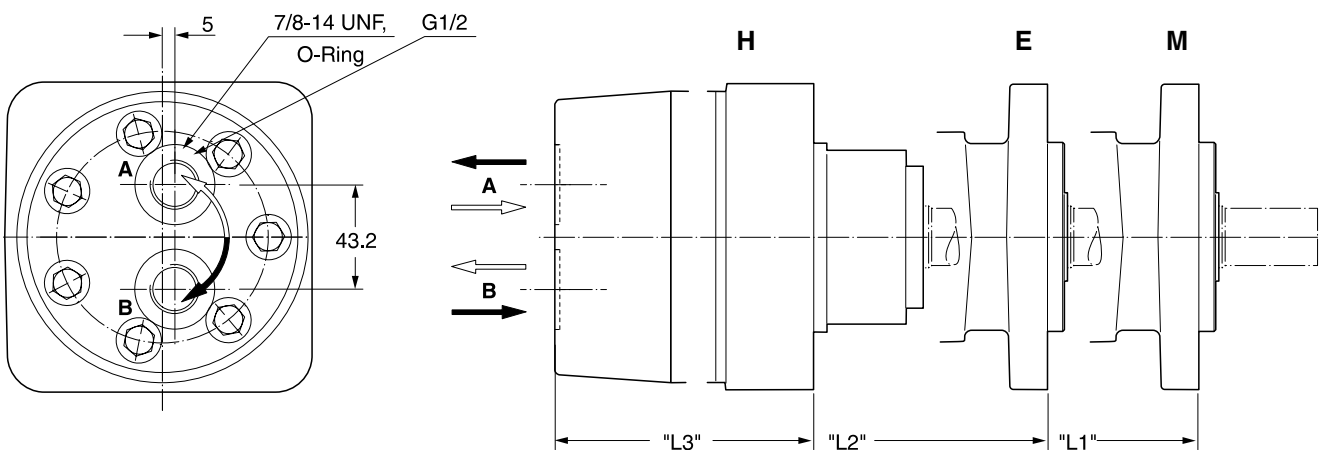

Gewicht / Poids / Peso [kg]	TF 80	TF100	TF130	TF140	TF170	TF195	TF240	TF280	TF360	TF405	TF475
	15,3	15,4	15,6	15,7	16,0	16,3	16,7	17,0	17,8	18,3	19,0
Code B, "L1"[mm]	211	211	214	216	219	222	227	231	240	245	254
A, X, Y, "L2"[mm]	216	216	219	221	224	227	232	236	246	250	259
L "L3"[mm]	170	170	173	175	178	181	186	191	201	205	213

Code 44

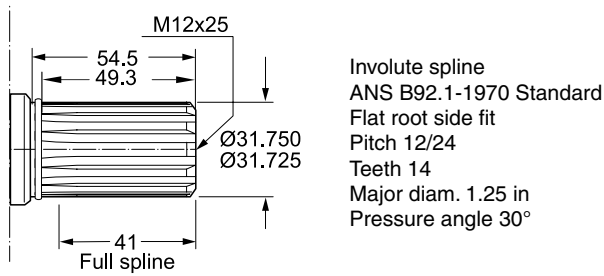

Code 45

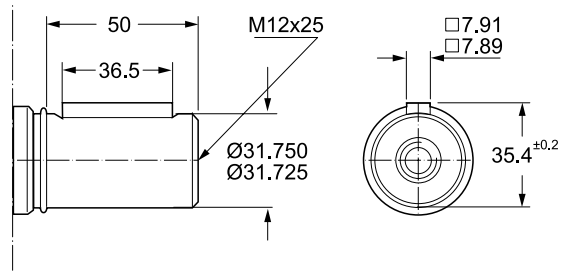

Code 08

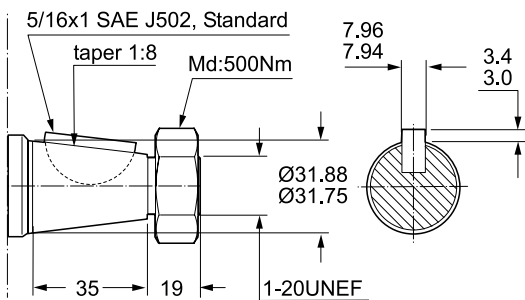

Code 46

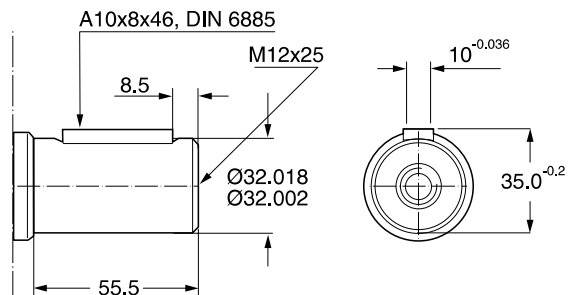

Code 26

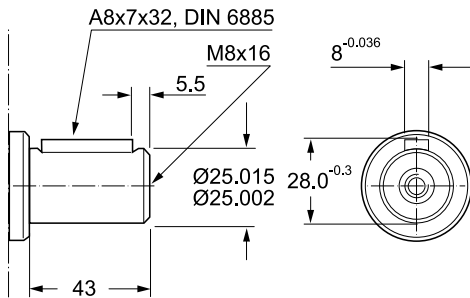

Code 47

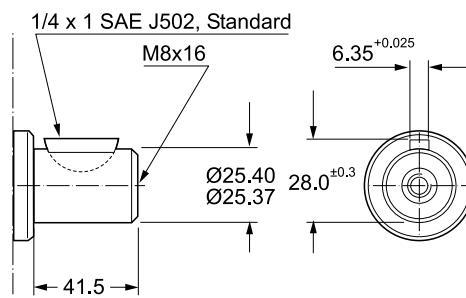

Code 41

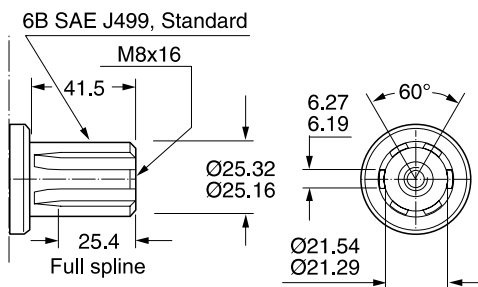

Codes 26, 41, 47

Abtriebswelle	Ø 25mm	Max. Moment cont./int.	} 450/550 Nm
Coupling shaft	Ø 1 inch	Max. torque cont./int.	
Arbre	6B SAE	Couple maxi cont./int.	
Albero		Coppia max cont./int.	

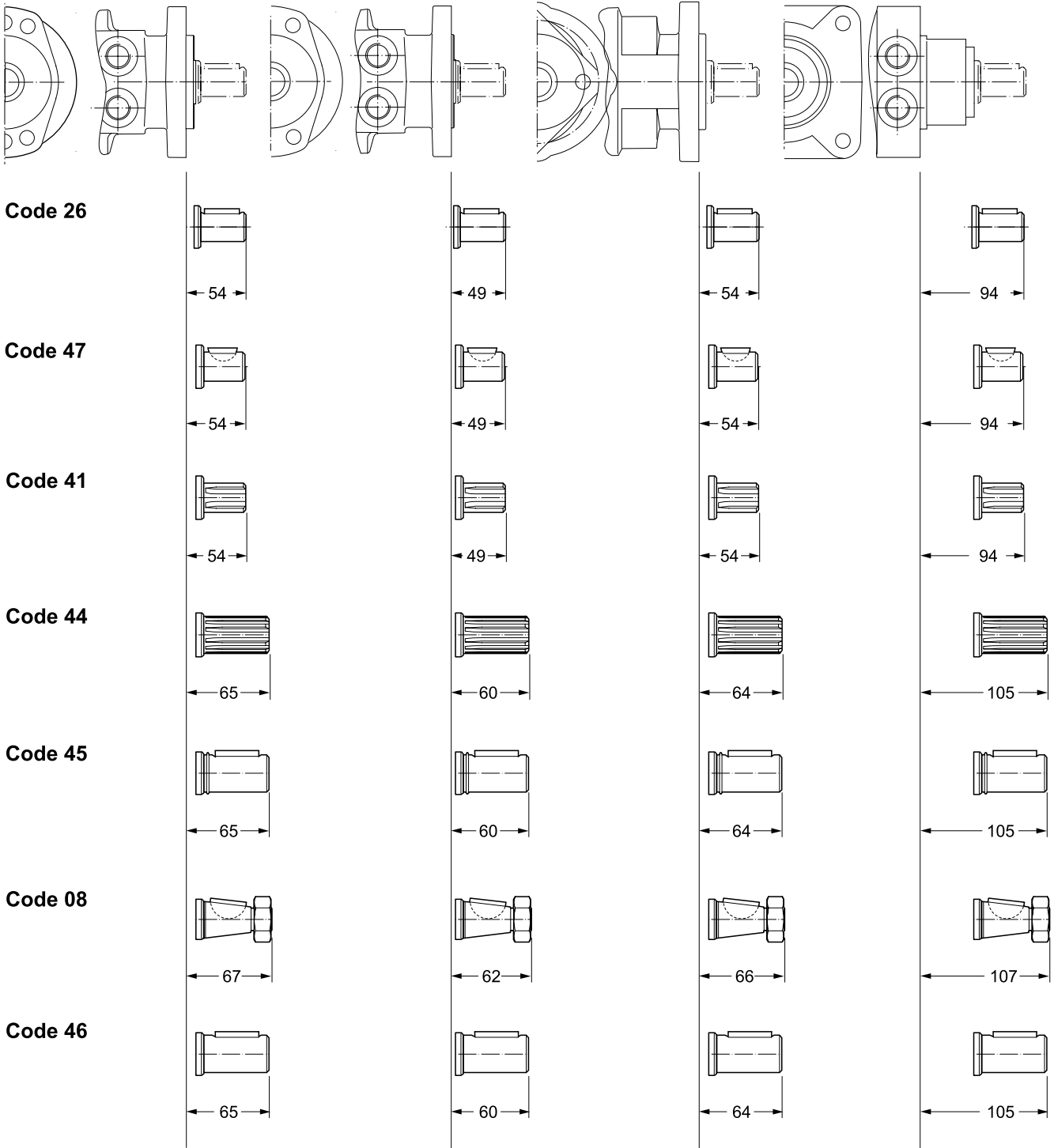

TF 80

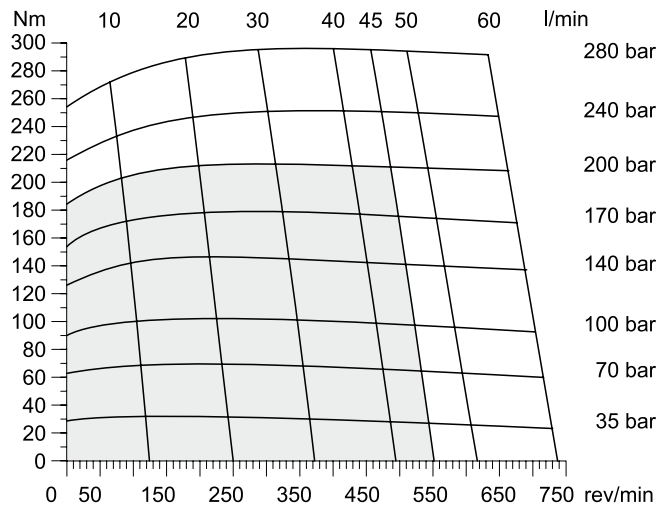

TF 100

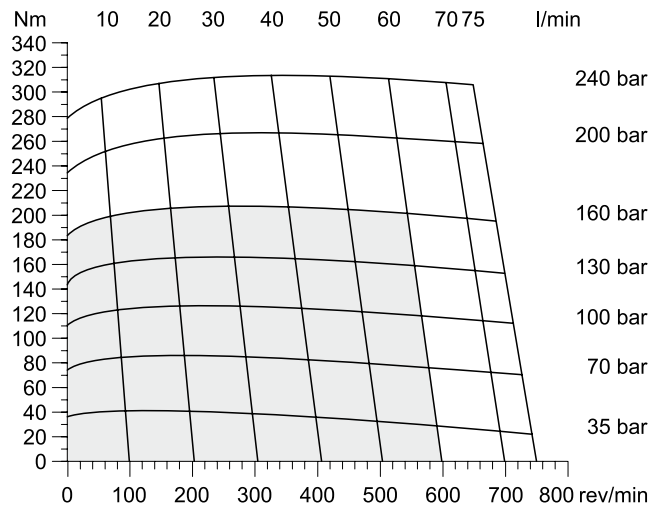

TF 130

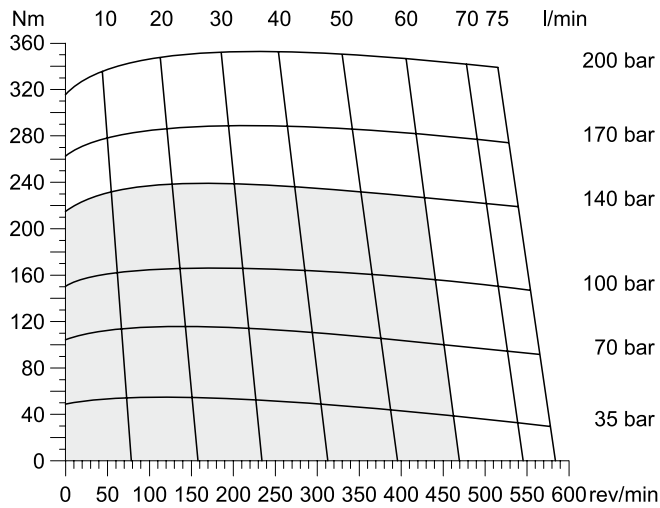

TF 140

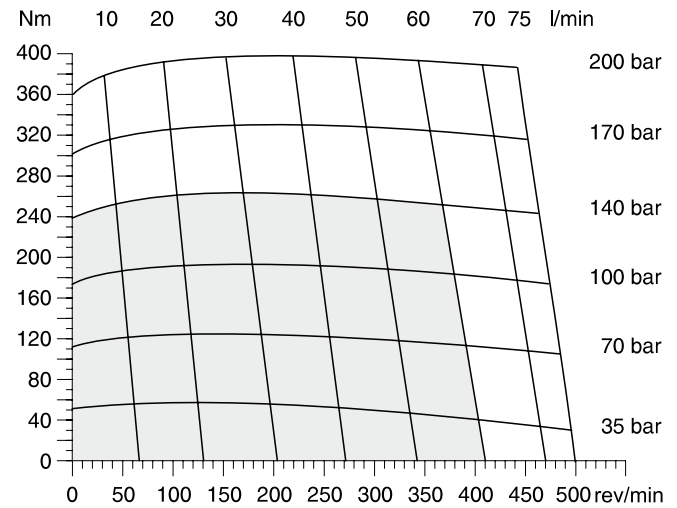

TF 170

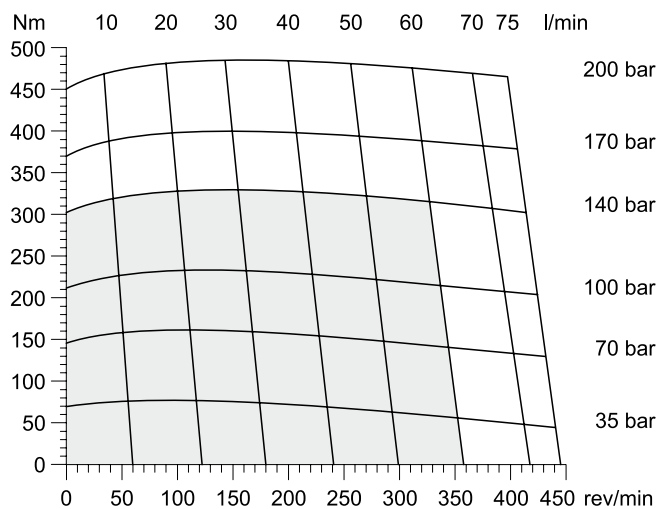

TF 195

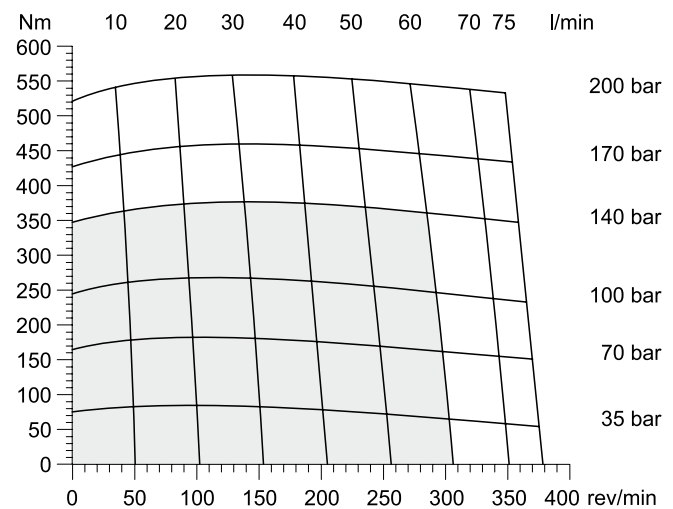

□ Cont. □ Int.

int. =
Intermittierende Werte maximal: 10% von jeder Betriebsminute.
Intermittent operation rating applies to 10% of every minute.
Fonctionnement interm.: 10% max. de chaque minute d'utilisation.
Servizio intermittente: 10% max di ogni minuto di utilizzazione.

TF 240

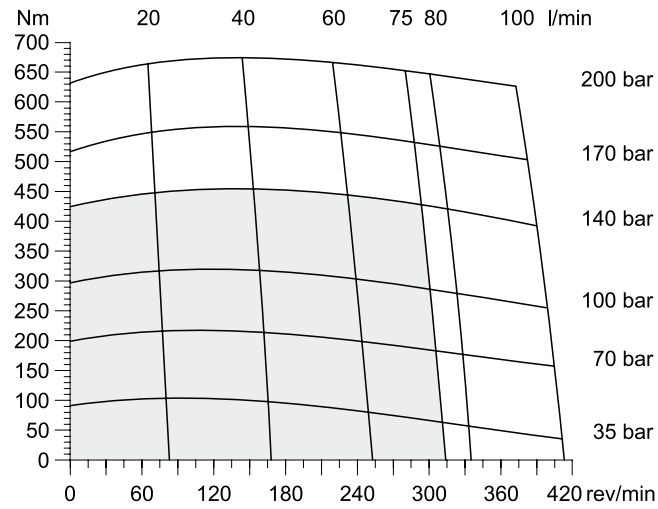

TF 280

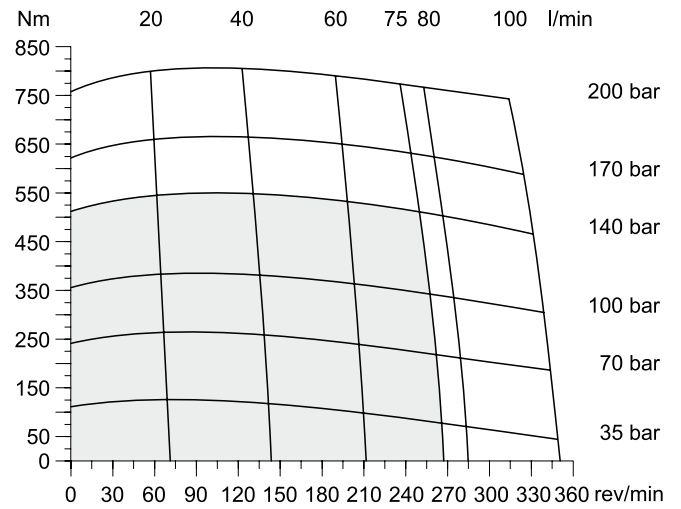

TF 360

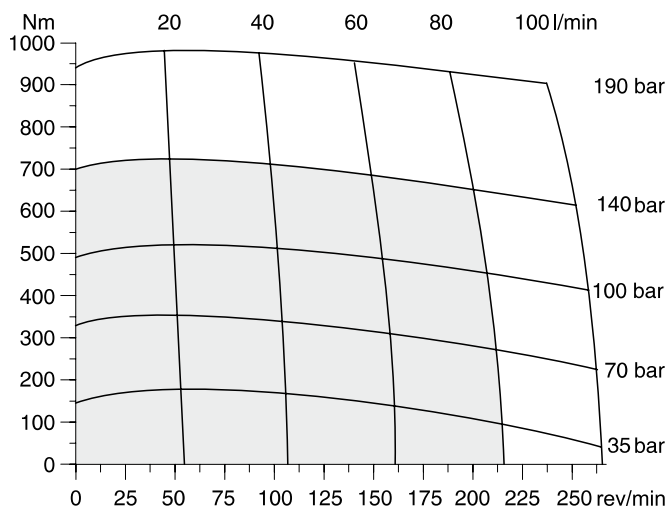

TF 405

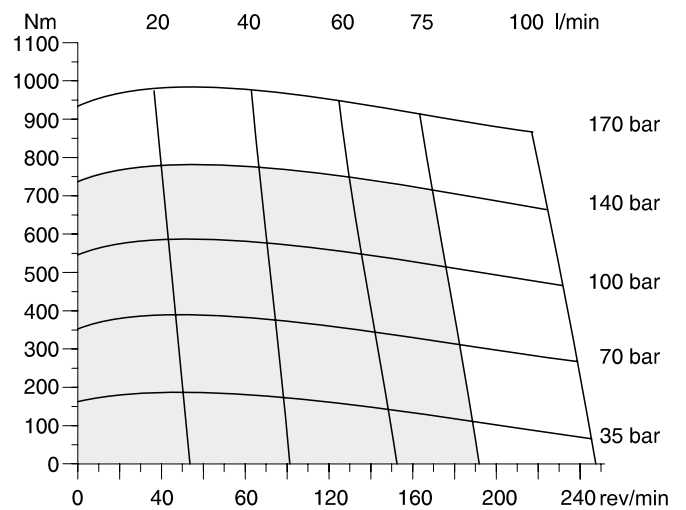

TF475

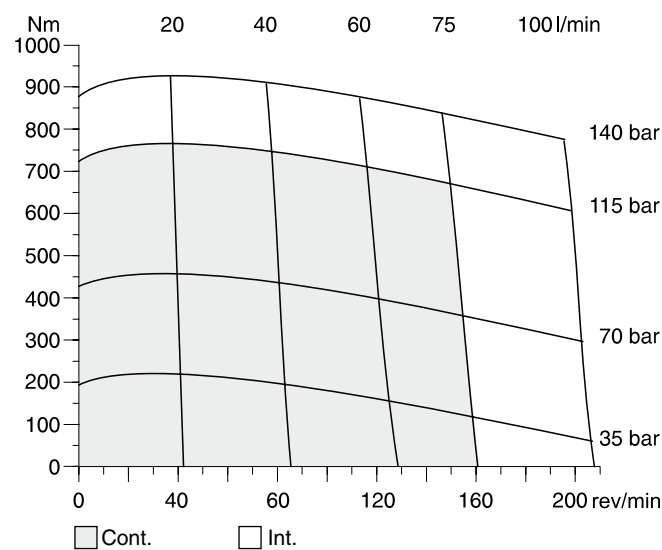

□ Cont. □ Int.

int. =
Intermittierende Werte maximal: 10% von jeder Betriebsminute.
Intermittent operation rating applies to 10% of every minute.
Fonctionnement interm.: 10% max. de chaque minute d'utilisation.
Servizio intermittente: 10% max di ogni minuto di utilizzazione.

Code E

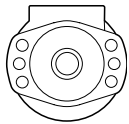

$$L_h = \frac{\left(\frac{670000}{F_R \cdot \left(1.10 + \frac{L}{88\text{mm}} \right)} \right)^{3.3}}{n}$$

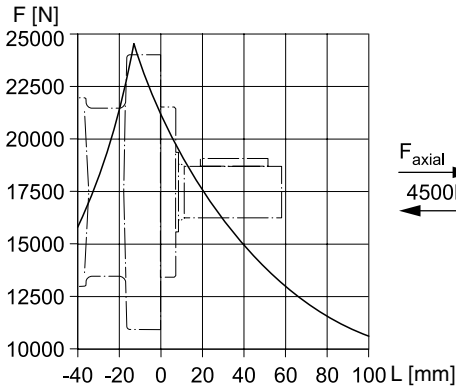

F_{Radial} [N]

Code M

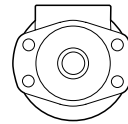

$$L_h = \frac{\left(\frac{670000}{F_R \cdot \left(1.16 + \frac{L}{88\text{mm}} \right)} \right)^{3.3}}{n}$$

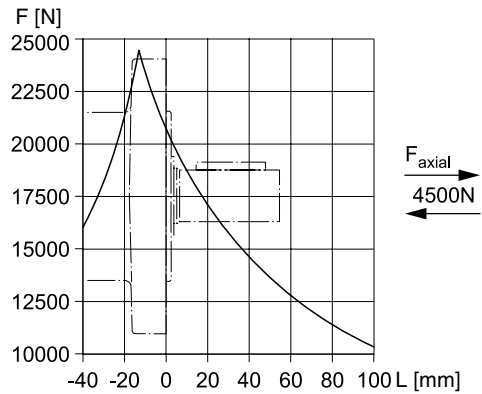

Code H

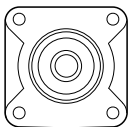

$$L_h = \frac{\left(\frac{670000}{F_R \cdot \left(0.56 + \frac{L}{88\text{mm}} \right)} \right)^{3.3}}{n}$$

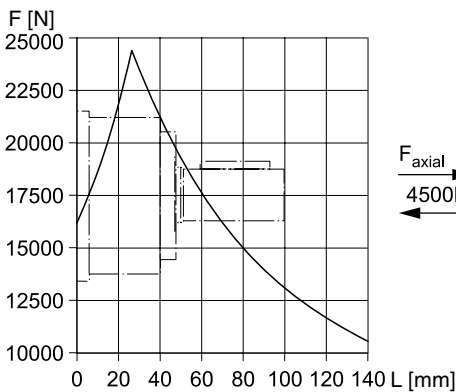

F_{Radial} [N]

Code V

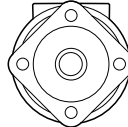

$$L_h = \frac{\left(\frac{670000}{F_R \cdot \left(1.11 + \frac{L}{88\text{mm}} \right)} \right)^{3.3}}{n}$$

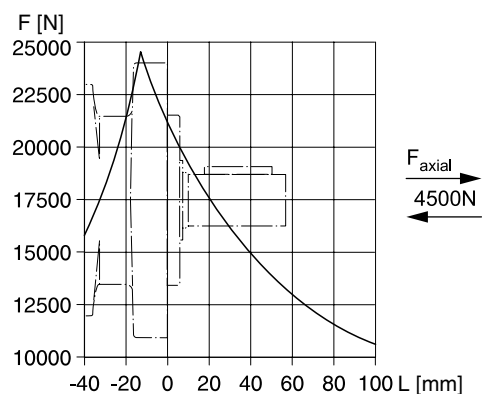

Die Lebensdauer der Radiallager (L_h in Stunden) lässt sich nach folgender Formel berechnen. Die Größe F_R ist durch die mechanische Festigkeit der Abtriebswelle begrenzt (siehe Diagramm). Das Maß "L" ist das Längenmaß vom Gehäuseflansch bis zum Angriffspunkt der Radialkraft F_R .

La durée de vie des roulements radiaux (L_h en heures) peut être calculée par les formules suivantes. La grandeur F_R est limitée par les résistances mécaniques de l'arbre de sortie (voir diagramme). La cote "L" est la longueur entre la bride du carter jusqu'au point d'appui de l'effort radial F_R .

Life time (L_h in hours) of the radial bearings can be calculated with the following formula. The value F_R is limited by the mechanical strength of the shaft (see diagram). The measurement "L" is the length from the housing flange up to the point of impact of the radial force F_R .

La durata dei cuscinetti (L_h in ore) può essere calcolata con la seguente formula. Il valore F_R è limitato dalla resistenza meccanica dell'albero (vedi diagramma). La quota "L" è la distanza tra la flangia del corpo ed il punto di applicazione della forza radiale F_R .

Vorstehende Formeln gelten für eine B10-Lebensdauer.
The preceding formulas are valid for a B10 duration of life.
Les formules précédentes sont valables pour une durée de vie B10.
Le formule precedenti sono valide per una durata della vita B10.

L_h = [h]
 L = [mm]
 n = [rev/min]

Ordering Code

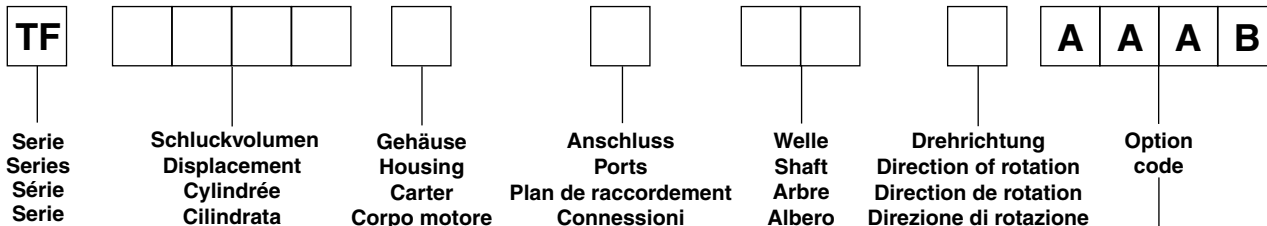

Code	cm ³ /rev
0080	81
0100	100
0130	128
0140	141
0170	169
0195	195
0240	237
0280	280
0360	364
0405	405
0475	477

Code	Housing
E	
M	
H	
V ¹⁾	

Code	Front port
W	G 1/2
V	7/8-14 UNF O-Ring
N ²⁾	Universal-M8x13
K ³⁾	Universal-M6x12

²⁾ Nicht verfügbar für Gehäuse "H"
Not possible for housing "H"
Pas disponible pour carter "H"
Non disponibile con il corpo codice "H"

³⁾ Nicht verfügbar für Gehäuse "M, E, V"
Not possible for housing "M, E, V"
Pas disponible pour carter "M, E, V"
Non disponibile con il corpo codice "M, E, V"

Code	Rear port
Y	G 1/2 Axial
A	7/8-14 UNF Axial
X	G 1/2 Radial
B	7/8-14 UNF Radial
L	Universal Radial M8x13

For further options different to standard 'AAAB' see page 84

Code	Front port
0	 Standard
1	

Code	Rear port
0	 Standard
1	

Code	Shaft
26 ⁴⁾	25
47 ⁴⁾⁵⁾	25.4
41 ⁴⁾⁵⁾	6B SAE
44	Pitch 12/24
45	31.75
08	
46	32

4) Codes 26, 41, 47
Abtriebswelle ø 25 mm Max. Moment cont./int. 450/550 Nm
Coupling shaft ø 1 inch Max. torque cont./int. 450/550 Nm
Arbre 6B SAE Couple maxi cont./int. 450/550 Nm
Albero Coppia max cont./int. 450/550 Nm

5) ≤TF0280

Exceptional Power Density and Durability

The heart of the new compact Torqmotor™ is the strongest drive train in its class. Coupled with this extra heavy-duty drive train are the high efficiencies and low speed performance for which the Parker Torqmotor™ is

known. As with all Torqmotors™, high speed valving and full flow drive train lubrication are standard. Case drains are not required. Roller vanes and a sealed commutator maintain high efficiencies and provide smooth low speed performance.

- **Langsamlaufender Gerotor-Motor**

- **Spezielle Orbital-Steuerung**

Geringe interne Leckage

Hoher volumetrischer Wirkungsgrad

- **Rollen im Rotorsatz**

Reduzierte Reibung

Lange Lebensdauer

- **Patentierte Hochdruckwellendichtung**

Keine Leckölleitung

Keine Rückschlagventile

- **Vielzahl von Varianten**

Großer Einsatzbereich

- **Moteur lent système Gerotor**

- **Une distribution orbitale particulière assure**

fuites internes minimales

rendements volumétriques élevés

- **Le rotor à rouleaux**

réduit les frottements

augmente la durée de vie

- **Par l'utilisation de joints d'arbre haute pression brevetés**

pas de conduite de drainage

pas de clapets anti-retour

- **Grâce à de nombreuses variantes**

larges domaines d'application

- **Low Speed Gerotor Motor**

- **Zero leak commutation valve**

For greater, more consistent

volumetric efficiency

- **Roller vane rotor set**

Reduces friction and internal leakage

Maintaining efficiency throughout the life of the motor

- **A patented high-pressure shaft seal**

No check valves needed

No extra plumbing

- **Wide choice of displacement range, flange and shaft options**

Greater efficiency in systems design to suit your application

- **Motore orbitale a bassa velocità**

- **Una particolare distribuzione orbitale assicura**

trafilamento ridotto

elevato rendimento volumetrico

- **Con lo statore a rullini**

si riduce l'attrito interno

si mantiene nel tempo l'efficienza del motore

- **Una guarnizione di tenuta ad alta pressione brevettata elimina la necessità**

di una linea di drenaggio esterna

e di valvole di non ritorno

- **Un'ampia gamma di cilindrata, flange ed alberi**

consentono scelte adeguate ad

ogni esigenza costruttiva

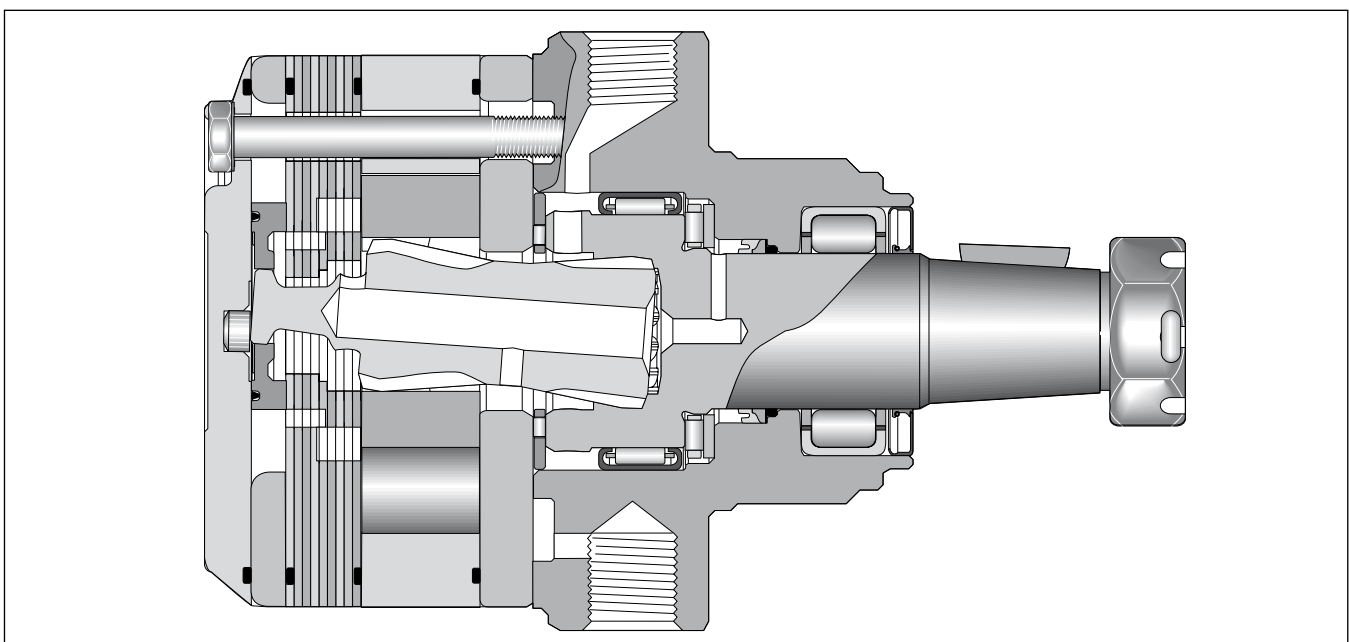

Performance

Displacements Schluckvolumen Cylindrée Despazamientos	140 . . . 364 cm ³ /rev	
Maximum Pressure Eingangsdruck Pression entrée Presion Maxima	Cont. 190 bar	Int. 241 bar
Maximum Oil Flow Schluckstrom Débit d'huile Caudal Maximo de Aceite	95 l/min	
Maximum Speed Drehzahl Vitesse de rotation Velocidad Maxima	484 rev/min	
Maximum Torque MaxDrehmoment Couple Torque Maximo	Cont. 977 Nm	Int. 1164 Nm

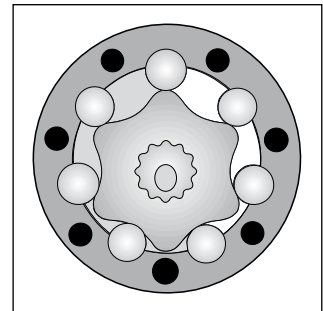
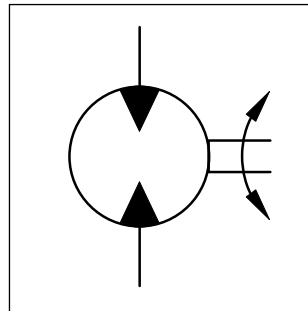

Motor series TF	Geom. Schluckvolumen Geometric displacement Cylindrée Cilindrata	Max. Drehzahl Max. speed Vitesse de rotation Velocità di rotazione	Max. Schluckstrom Max. oil flow Débit d'huile Portata max	Max. Druckdifferenz * Max. differential pressure * Chute de pression maxi * Caduta di pressione maxi *	Max. Eingangsdruck Max. supply pressure Pression maxi entrée Pressione maxi in entrata	Max. Drehmoment Max. torque Couple maxi Coppia maxi	Max. Leistungabgabe Max. performance Puissance de sortie maxi Potenza meccanica max	Min. Anlaufmoment Min. starting torque Couple min. fourni au démarrage Coppia min. di spunto
	[cm ³ /U] [cm ³ /rev]	cont / int [U/min] [rev/min]	cont / int [l/min]	cont / int [bar]	max [bar]	cont / int [Nm]	cont / int [KW]	cont / int [Nm]
TL0140	140	613	68/95	190/241	300	364/463	30	294/365
TL0170	169	512	68/95	190/241	300	449/570	31	354/445
TL0195	195	484	68/95	190/241	300	511/648	34	414/526
TL0240	238	399	68/95	190/241	300	620/790	34	536/679
TL0280	280	335	68/95	190/241	300	730/929	34	619/787
TL0310	310	310	68/95	190/241	300	847/1079	36	713/907
TL0360	364	255	68/95	172/224	300	890/1163	31	778/1002

int. =

Intermittierende Werte maximal: 10% von jeder Betriebsminute.

Intermittent operation rating applies to 10% of every minute.

Fonctionnement interm.: 10% max. de chaque minute d'utilisation.

Servizio intermittente: 10% max di ogni minuto di utilizzazione.

- * Druckdifferenz Δp zwischen Ein- und Ausgang
- * Pressure difference is Δp between input and output
- * La différence de pression est Δp entre l'entrée et la sortie
- * La differenza di pressione corrisponde al Δp tra ingresso e uscita

Achtung: Höhere Drücke auf Anfrage möglich.

Notice: Higher pressures are possible on request.

Remarque : des pressions supérieures sont possibles sur demande.

Nota: Pressioni superiori possibili su richiesta.

Code: L

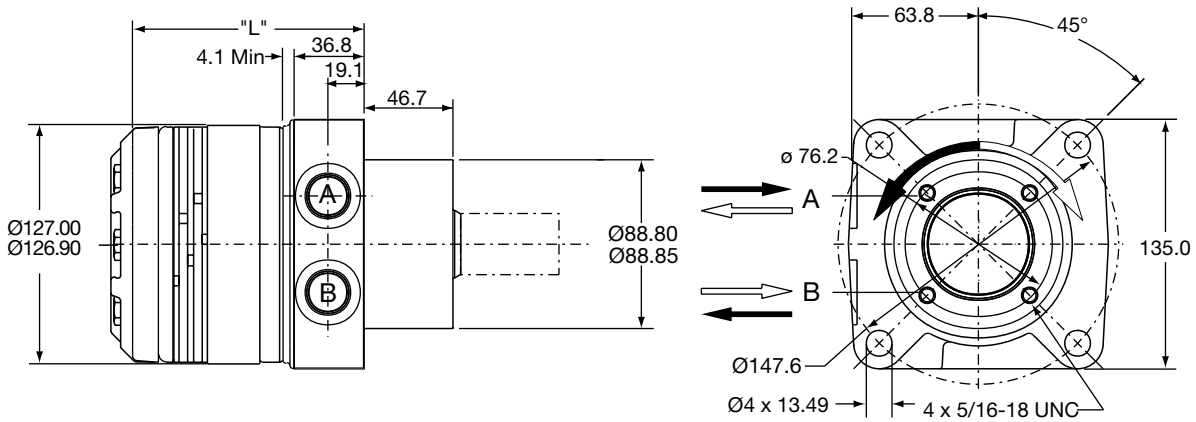

Code L	disp.	0140	0170	0195	0240	0280	0310	0360
Weight/Gewicht	kg	10.9	11.1	11.4	11.8	12.2	12.4	12.9
Poids/Peso								
Length	"L" mm	124	124	124	127	132	135	143

Code: U

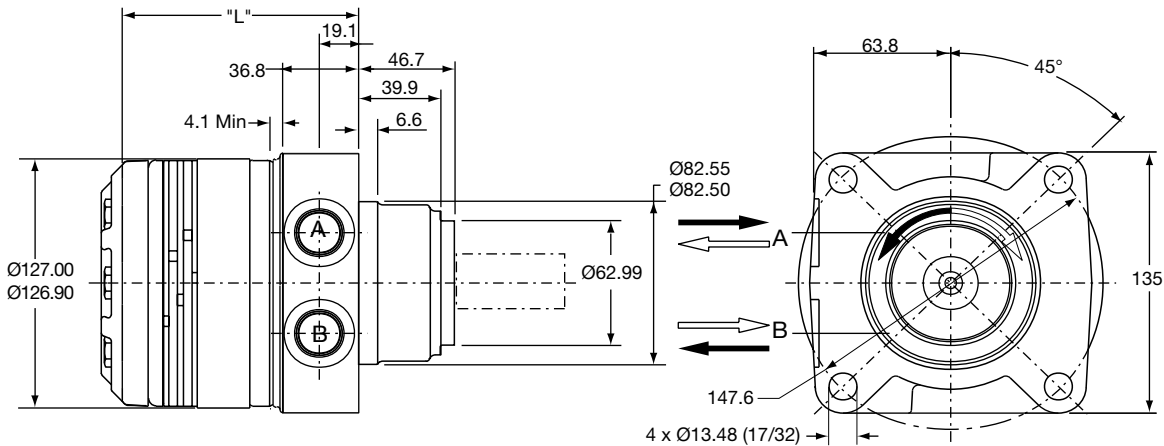

Code U	disp.	0140	0170	0195	0240	0280	0310	0360
Weight/Gewicht	[kg]	10.9	11.1	11.4	11.8	12.2	12.4	12.9
Poids/Peso								
Length	"L" mm	124	124	124	127	132	135	143

Code: S

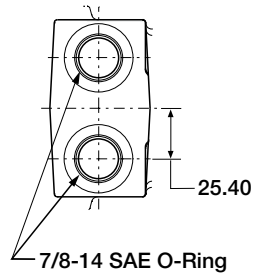

**Shafts / Abtriebswellen
 Arbore / Ejes**

Code: L, U

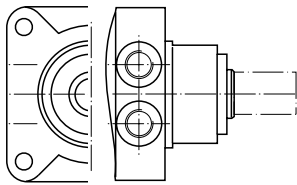

Code: 08

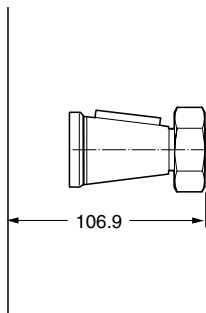

Code: 08

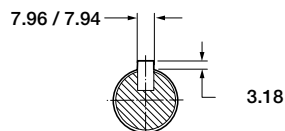
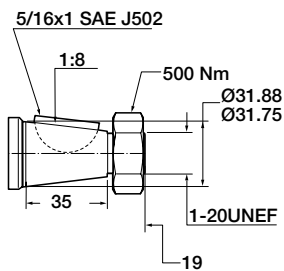

TL 140

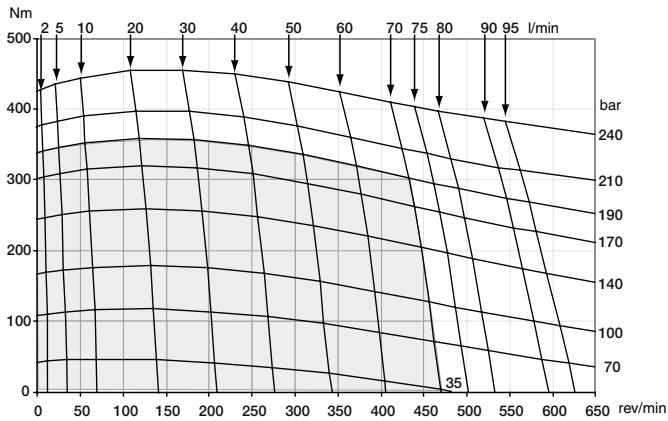

TL 169

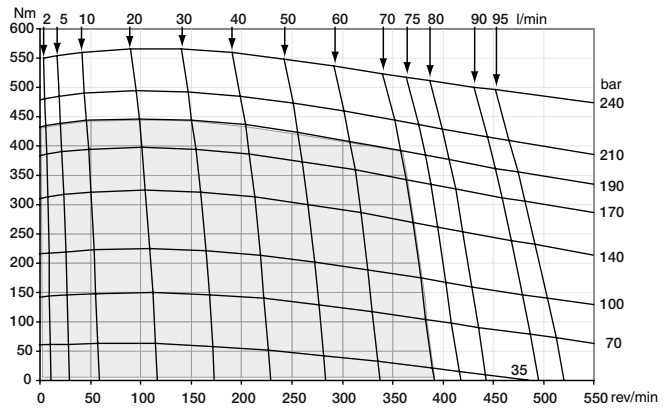

TL 195

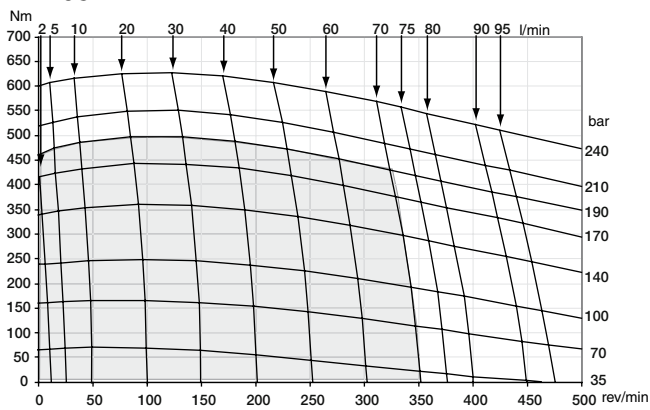

TL 238

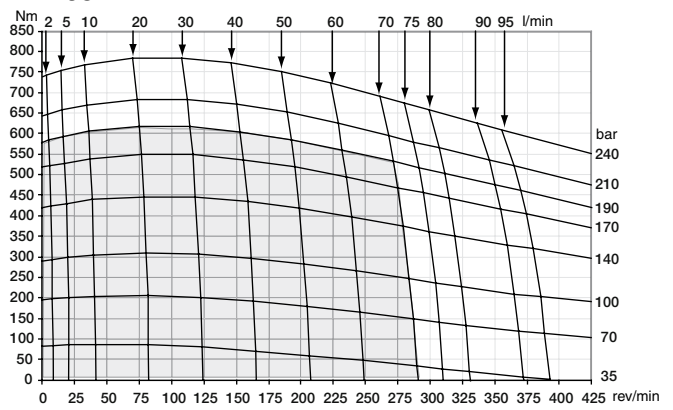

TL 280

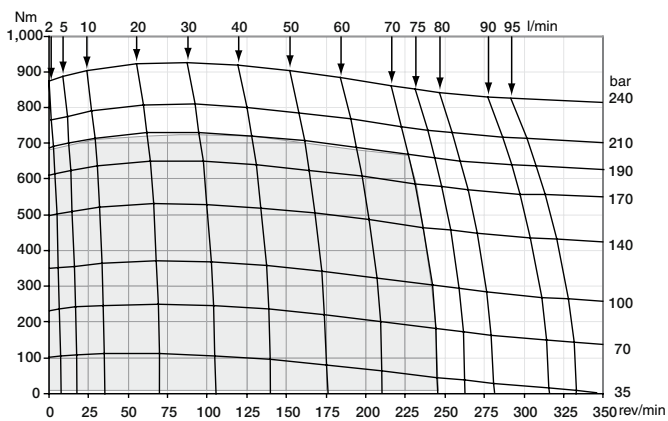

TL 310

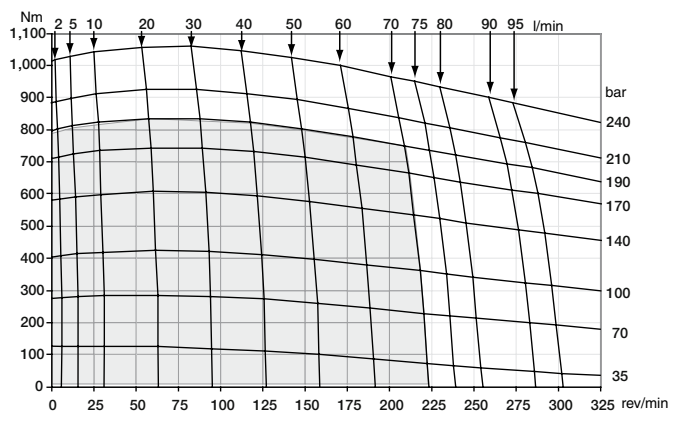

TL 334

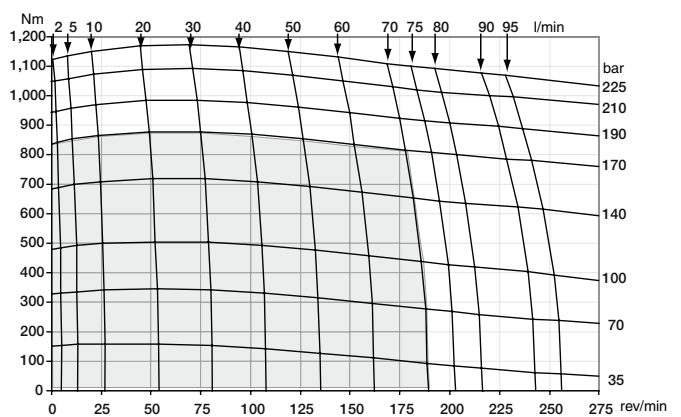

Cont. Int.

int. =
Intermittierende Werte maximal: 10% von jeder Betriebsminute.
Intermittent operation rating applies to 10% of every minute.
Fonctionnement interm.: 10% max. de chaque minute d'utilisation.
Servizio intermittente: 10% max di ogni minuto di utilizzazione.

Wheel Mount / Radnabengehäuse

Monture à roue/ Montaje de rueda

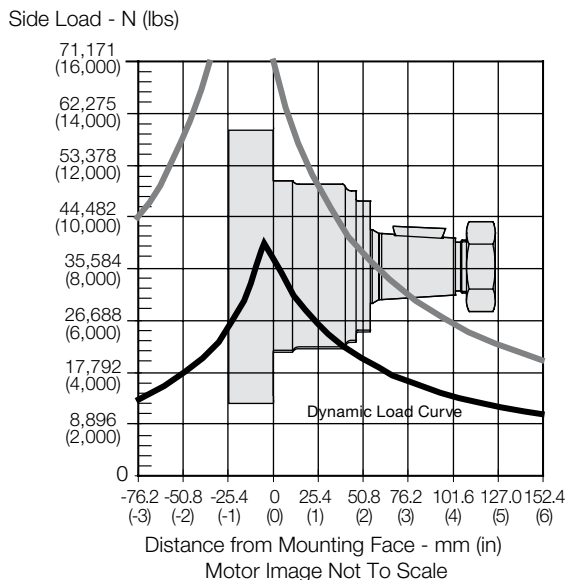

The dynamic side load curve is based on uni-directional steady state loads for L₁₀ bearing life at 3 x 10⁶ revolutions.

Die zulässige auslegbare radiale Wellenbelastungskurve ist unter ruhenden, einseitig statisch gerichteten Lastverhältnissen auf eine L₁₀ Lebensdauer mit 3 x 10⁶ Umdrehungen kalkuliert.
 La courbe de charge latérale permise se base sur des charges unidirectionnelles en régime permanent pour le roulement L₁₀ à 3 x 10⁶ révolutions.
 La curva de valores admisibles de carga lateral está basada en cargas constantes para cojinetes L₁₀ a 3 x 10⁶ revoluciones.

The maximum load curve is defined by bearing static load capacity. This curve should not be exceeded at any time including shock loads.

Die maximale radiale Wellenbelastungskurve ist definiert als maximale statische Last ohne Drehzahl. Sie gilt als Grenze und sollte keinesfalls überschritten werden.
 La courbe de charge maximale est définie par la capacité de charge statique portante. Cette courbe ne devrait être dépassée en aucun moment y compris pour les charges par à-coups.
 La curva de carga máxima queda definida por la capacidad de carga estática del cojinete. No se deben superar los valores de esta curva, ni siquiera con cargas provisorias de impacto.

**Equation to Calculate the Expected Radial Bearing Life
 Gleichung zur Ermittlung der Lagerlebensdauer**

Equation to calculate the dynamic bearing life for a given load:
 Bestimmung der erlaubten radialen Wellenbelastung mit vorgegebener Last

Use F_a, F_b and S in equation to determine hours of L₁₀ bearing life.
 Die Lebensdauer in Stunden ergibt sich durch einsetzen von F_a, F_b, und S in die nachstehende Formel.

$$L = \frac{3 \times 10^6}{60 \times S} \left\{ \frac{F_a}{F_b} \right\}^{3.33}$$

Where / Mit:

- S = Shaft Speed RPM / Abtriebswellendrehzahl in min⁻¹
- L = Life In Hours / Lebensdauer in Stunden
- F_a = Dynamic side load defined by above curve at a distance from mounting flange. / Erlaubte radiale Wellenbelastung als Function der Laenge
- F_b = Application side load. / Anwendungsseitige Wellenbelastung

Ordering Code

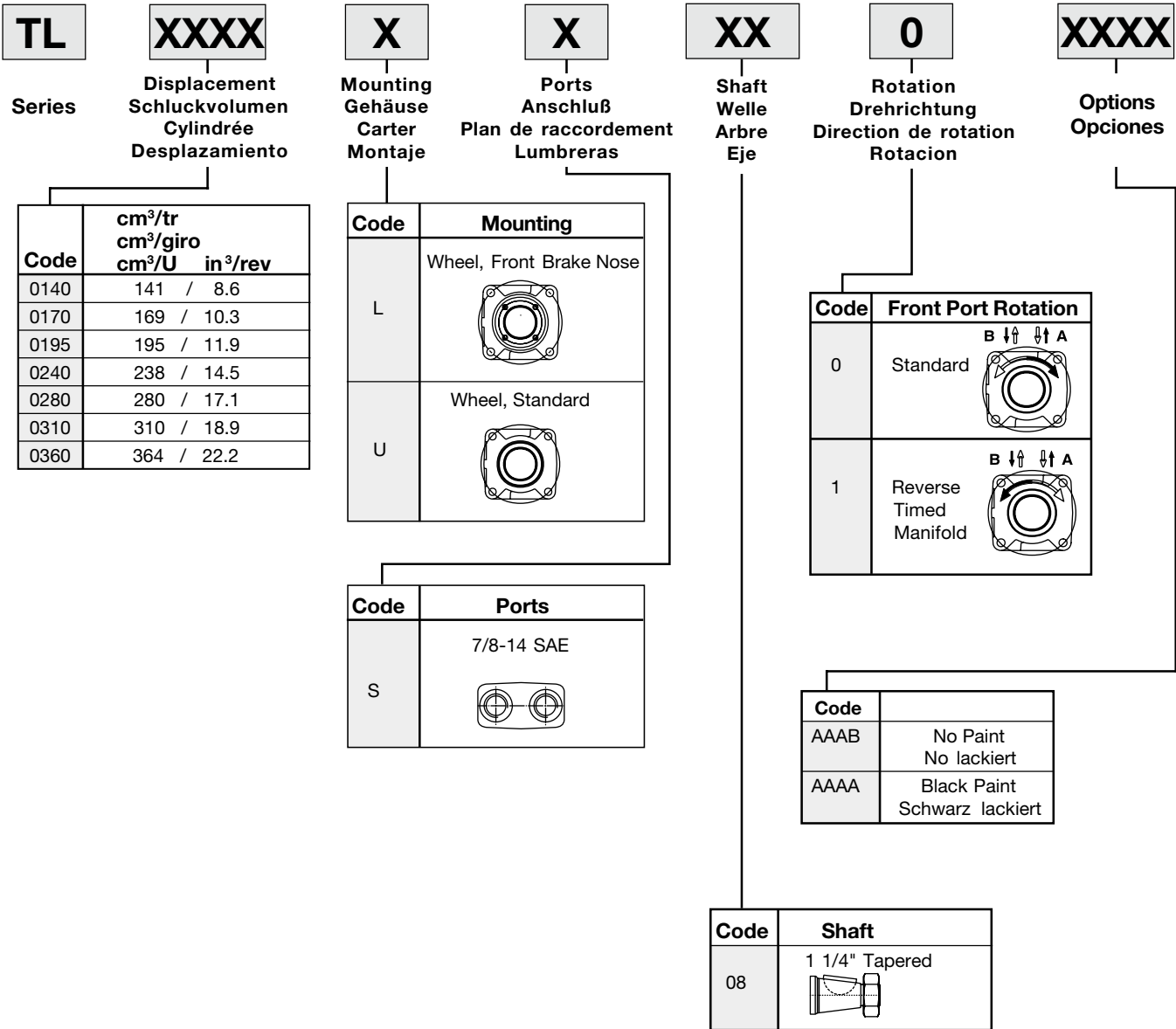

- **Langsamlaufender Gerotor-Motor**
 - **Spezielle Orbital-Steuerung**
Geringe interne Leakage
Hoher volumetrischer Wirkungsgrad
 - **Rollen im Rotorsatz**
Reduzierte Reibung
Lange Lebensdauer
 - **Patentierte Hochdruckwellendichtung**
Keine Leckölleitung
Keine Rückschlagventile
 - **Vielzahl von Varianten**
Großer Einsatzbereich
- **Low Speed Gerotor Motor**
 - **Zero leak commutation valve**
For greater, more consistent volumetric efficiency
 - **Roller vane rotor set**
Reduces friction and internal leakage
Maintaining efficiency throughout the life of the motor
 - **A patented high-pressure shaft seal**
No check valves needed
No extra plumbing
 - **Wide choice of displacement range, flange and shaft options**
Greater efficiency in systems design to suit your application
- **Moteur lent système Gerotor**
 - **Une distribution orbitale particulière assure**
fuites internes minimales
rendements volumétriques élevés
 - **Le rotor à rouleaux**
réduit les frottements
augmente la durée de vie
 - **Par l'utilisation de joints d'arbre haute pression brevetés**
pas de conduite de drainage
pas de clapets anti-retour
 - **Grâce à de nombreuses variantes**
larges domaines d'application
- **Motore orbitale a bassa velocità**
 - **Una particolare distribuzione orbitale assicura**
trafilamento ridotto
elevato rendimento volumetrico
 - **Con lo statore a rullini**
si riduce l'attrito interno
si mantiene nel tempo l'efficienza del motore
 - **Una guarnizione di tenuta ad alta pressione brevettata elimina la necessità**
di una linea di drenaggio esterna
e di valvole di non ritorno
 - **Un'ampia gamma di cilindrate, flange ed alberi**
consentono scelte adeguate ad ogni esigenza costruttiva

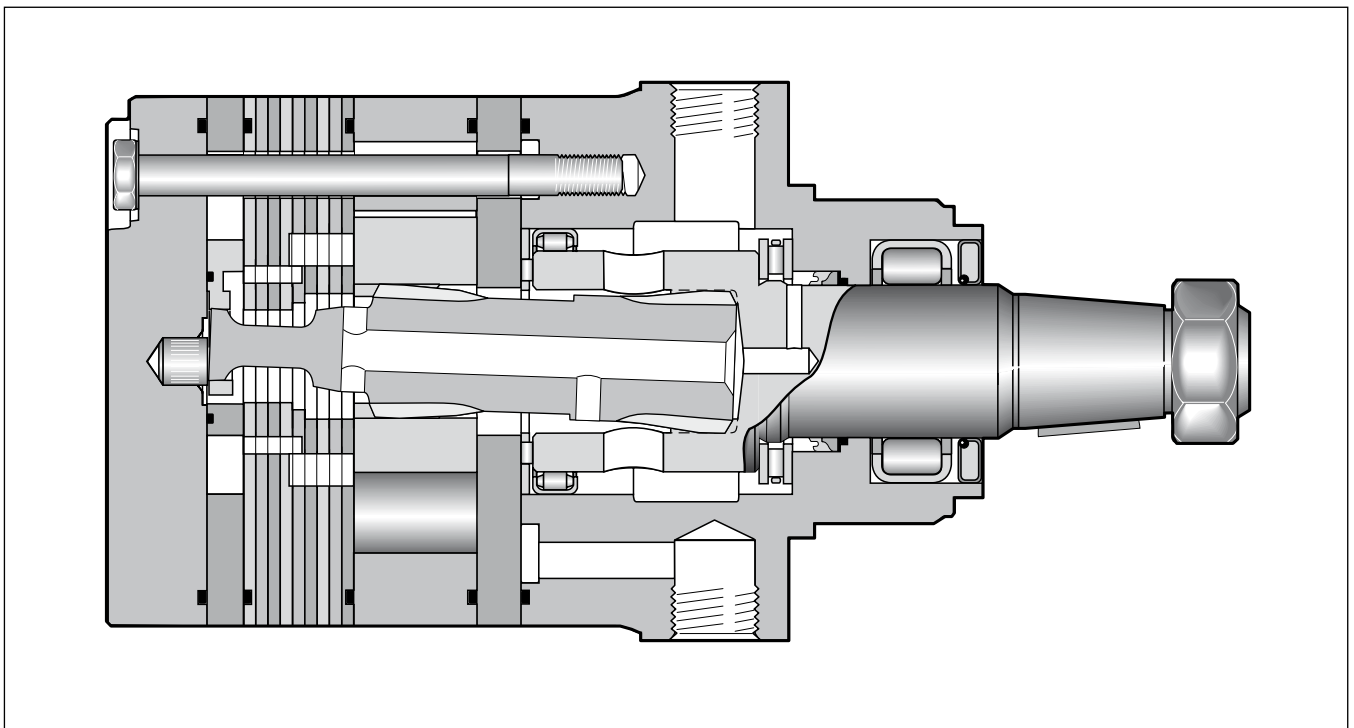

Performance

Drehzahl Speed Vitesse de rotation Velocità di rotazione	5...710 rev/min
Schluckstrom Oil flow Débit d'huile Portata	max. 115 l/min
Eingangsdruck Supply pressure Pression entrée Pressione in entrata	max. 300 bar
Drehmoment Torque Couple Coppia	max. 1490 Nm
Seitenlast Side load Charges latérales Carico radiale	max. 16.000 N

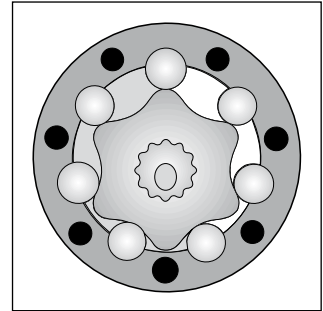
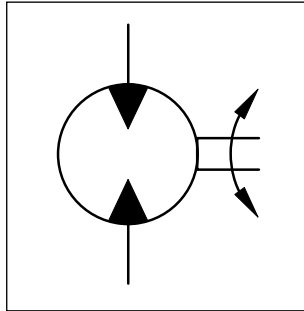

Geom. Schluckvolumen Geometric displacement Cylindrée Cilindrata	Max. Drehzahl Max. speed Vitesse de rotation maxi Velocità di rotazione max	Max. Schluckstrom Max. oil flow Débit d'huile max Portata max	Max. Druckdifferenz * Max. differential pressure * Chute de pression maxi * Caduta di pressione max *	Max. Eingangsdruck Max. supply pressure Pression maxi entrée Pressione max in entrata	Max. Drehmoment Max. torque Couple maxi Coppia max	Max. Leistungsgabe Max. performance Puissance de sortie maxi Potenza meccanica max	Min. Anlaufmoment Min. starting torque Couple min. fourni au démarrage Coppia min. di spunto
---	--	--	--	--	---	---	---

Motor series TF	[cm ³ /U] [cm ³ /rev]	cont / int [U/min] [rev/min]	cont / int [l/min]	cont / int [bar]	max [bar]	cont / int [Nm]	cont / int [KW]	cont / int [Nm]
TG 140	141	530/710	75/100	210/280	300	400/545	33	320/436
TG 170	169	440/575	75/100	210/280	300	485/670	33	388/536
TG 195	195	380/510	75/100	210/280	300	560/770	33	448/616
TG 240	238	320/420	75/100	210/280	300	685/945	32	548/756
TG 280	280	270/350	75/100	210/280	300	800/1100	31	675/880
TG 335	337	225/290	75/100	210/280	300	980/1350	30	784/1080
TG 405	405	185/245	75/100	170/240	300	960/1350	27	791/1145
TG 475	477	160/240	75/115	140/210	300	960/1400	28	768/1120
TG 530	529	140/215	75/115	140/170	300	1050/1280	23	874/1091
TG 625	613	120/185	75/115	120/160	300	1040/1360	20	895/1165
TG 785	786	95/145	75/115	100/140	300	1150/1490	17	991/1341
TG 960	959	78/119	75/115	70/100	300	925/1390	12	763/1177

int. =
Intermittierende Werte maximal: 10% von jeder Betriebsminute.
Intermittent operation rating applies to 10% of every minute.
Fonctionnement interm.: 10% max. de chaque minute d'utilisation.
Servizio intermittente: 10% max di ogni minuto di utilizzazione.

- * Druckdifferenz Δp zwischen Ein- und Ausgang
- * Pressure difference is Δp between input and output
- * La différence de pression est Δp entre l'entrée et la sortie
- * La differenza di pressione corrisponde al Δp tra ingresso e uscita

Achtung: Höhere Drücke auf Anfrage möglich.
Notice: Higher pressures are possible on request.
Remarque : des pressions supérieures sont possibles sur demande.
Nota: Pressioni superiori possibili su richiesta.

Code E

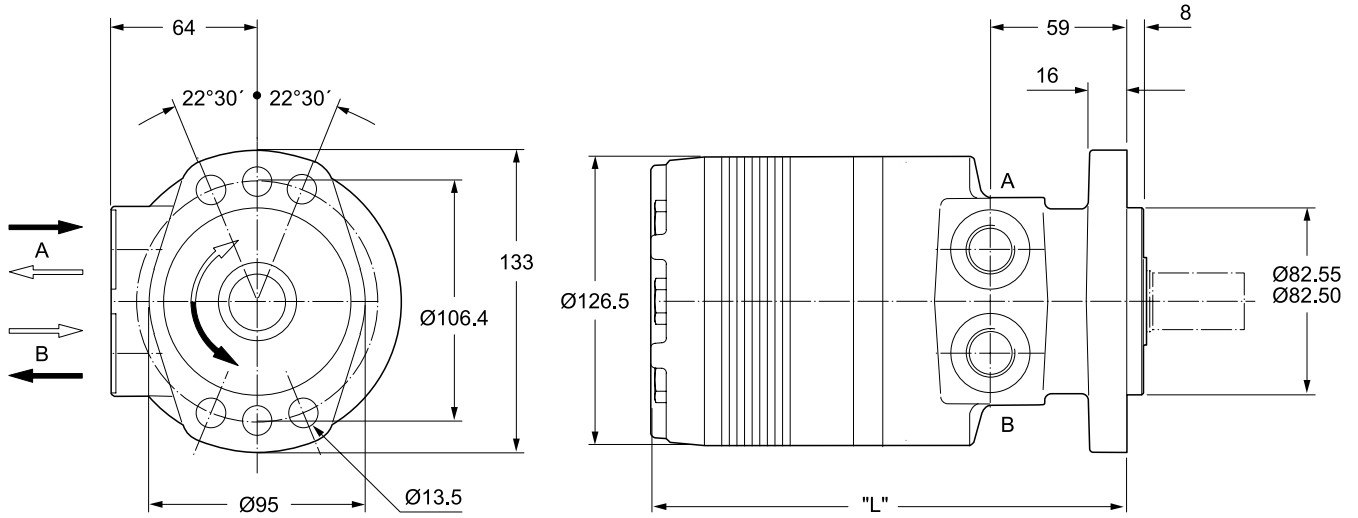

Code M

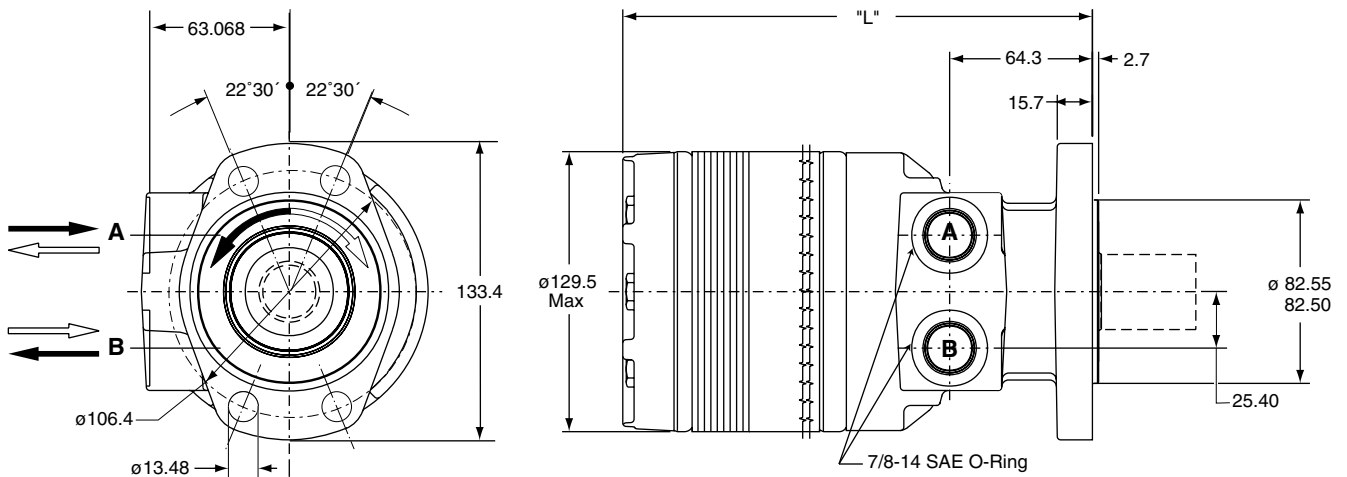

Gewicht / Weight Poids / Peso [kg]	TG140	TG170	TG195	TG240	TG280	TG335	TG405	TG475	TG530	TG625	TG785	TG960	
		14.2	14.5	14.7	15.1	15.5	15.9	16.5	17.2	17.9	18.6	20.2	22.0
Code H	"L" [mm]	191	194	197	202	207	213	220	229	235	245	264	283
Code V	"L" [mm]	196	199	202	208	212	218	225	234	240	250	269	288

Code H

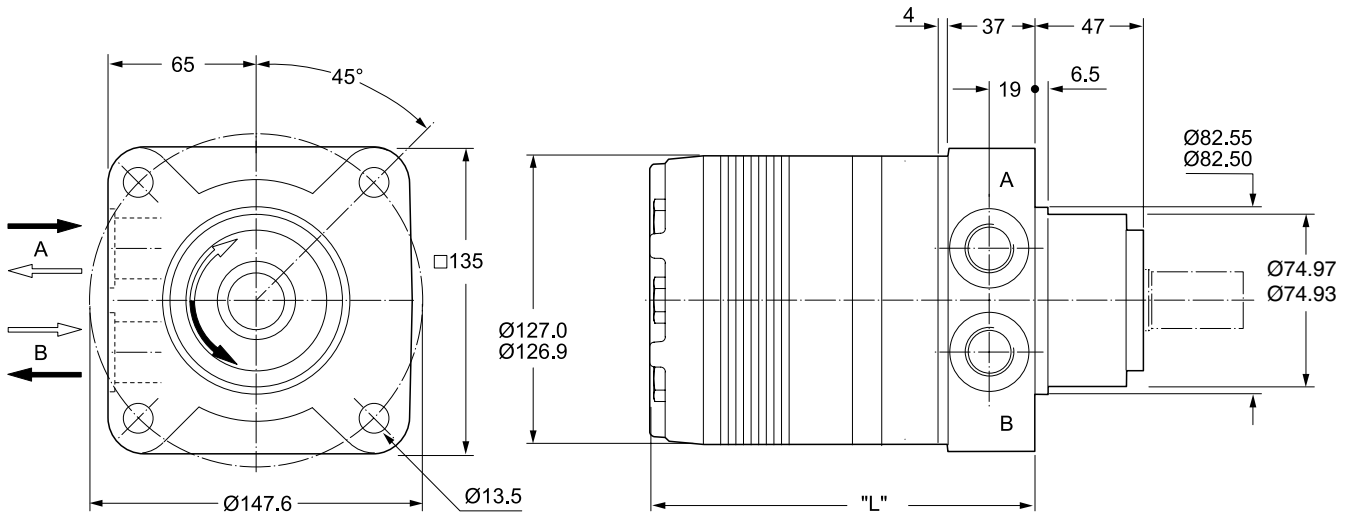

Code V

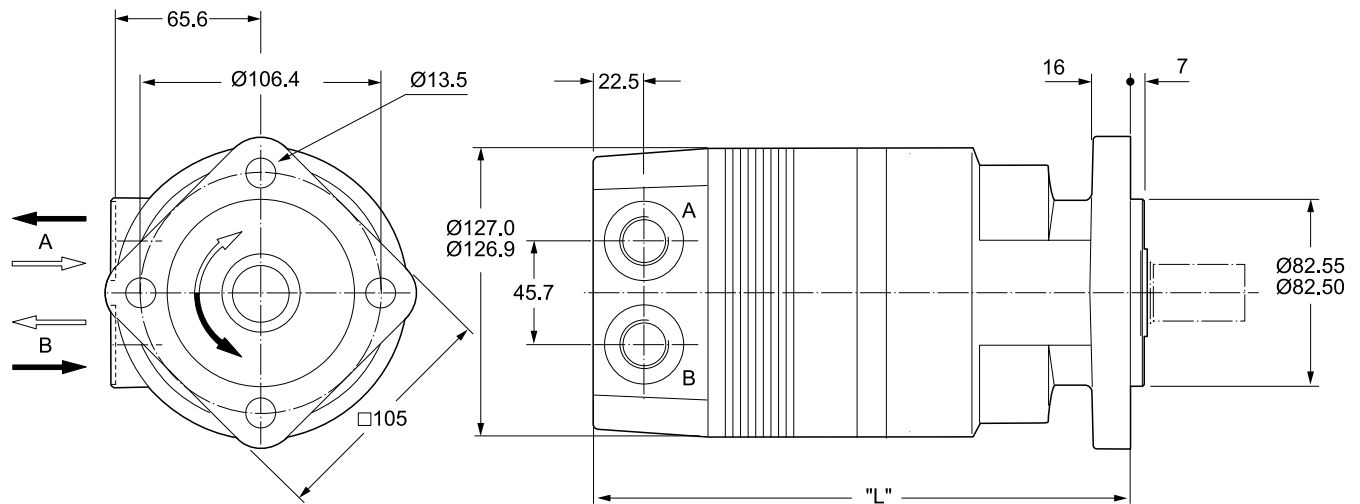

Gewicht / Poids / Peso [kg]	Weight	TG140	TG170	TG195	TG240	TG280	TG335	TG405	TG475	TG530	TG625	TG785	TG960
		Code H	"L" [mm]	150	154	157	162	166	173	180	188	195	204
Code V	"L" [mm]	217	220	224	228	233	238	246	255	262	272	290	309

Code W

G1/2 x 15

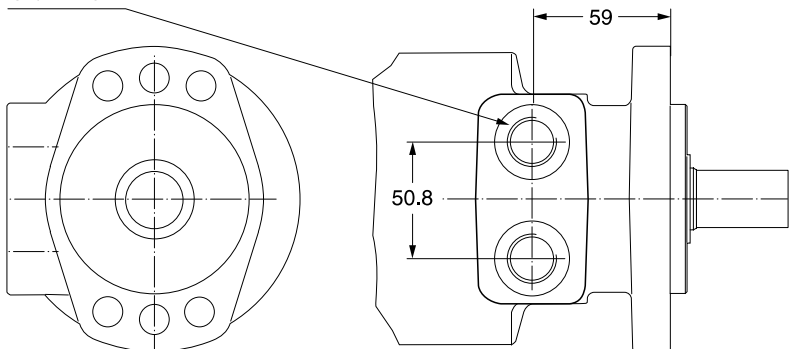

Code: N

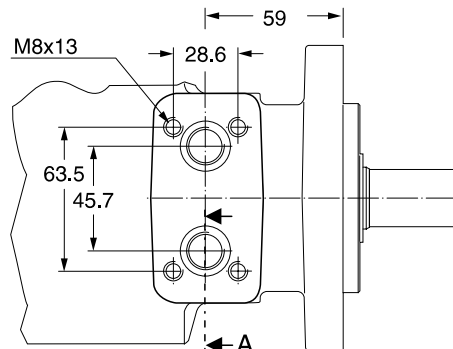

Code W

G1/2 x 15

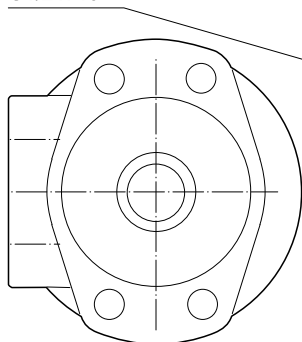

Code V

7/8-14UNF,
 O-Ring

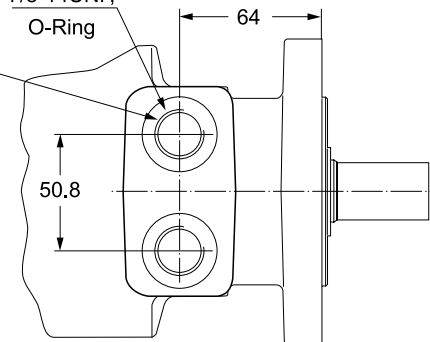

Code N

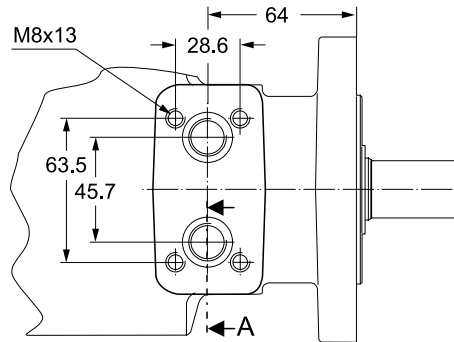

Code W

G1/2 x 15

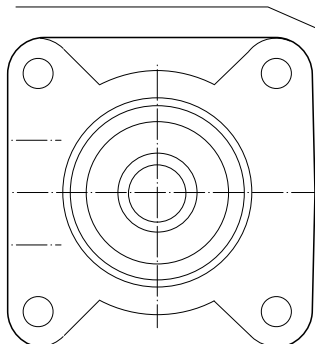

Code V

7/8-14UNF,
 O-Ring

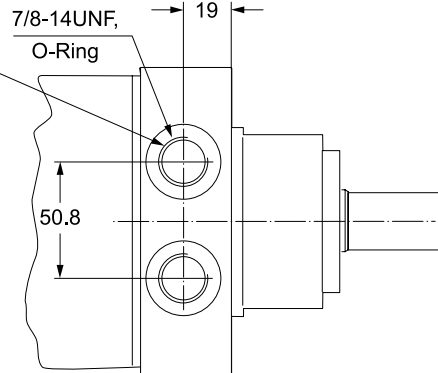

Code K

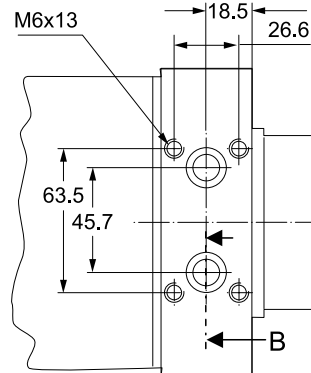

Section A

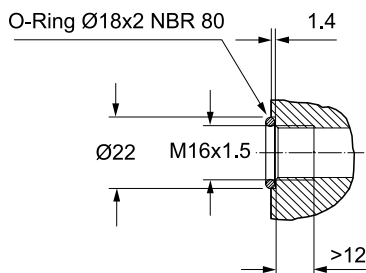

Section B

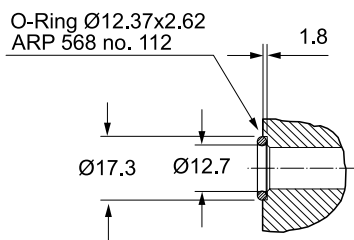

Zum Motor mit Universalanschluss werden 2 O-Ringe geliefert.

Motor with manifold mount is supplied with 2 O-rings.

Deux joints toriques sont livrés avec les moteurs au plan de raccordement universel.

Il blocchetto connessioni è corredato da 2 OR.

Code B 7/8-14UNF **Code X** G 1/2

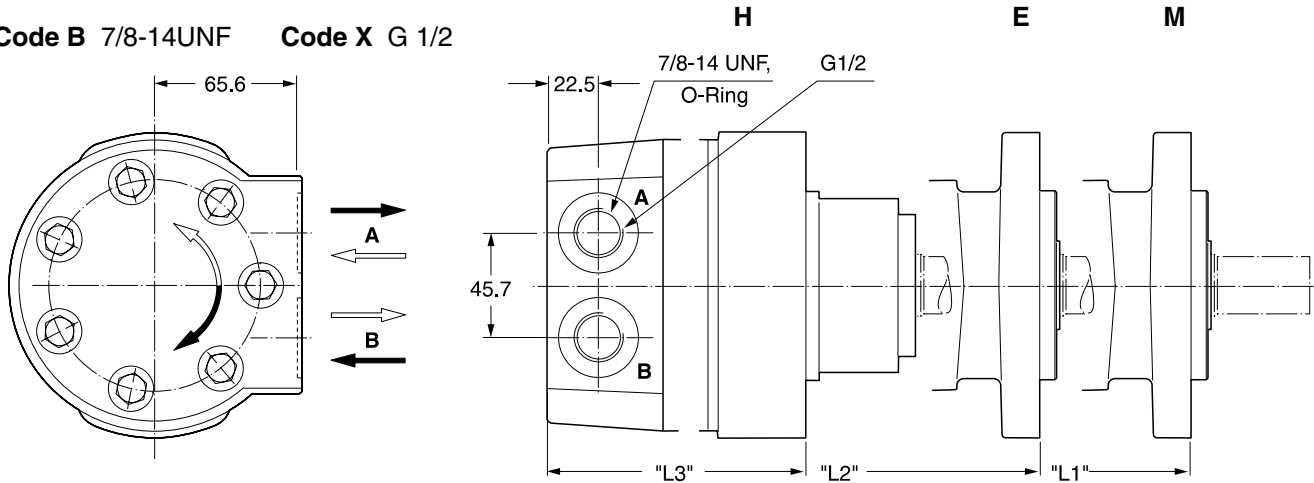

Code L

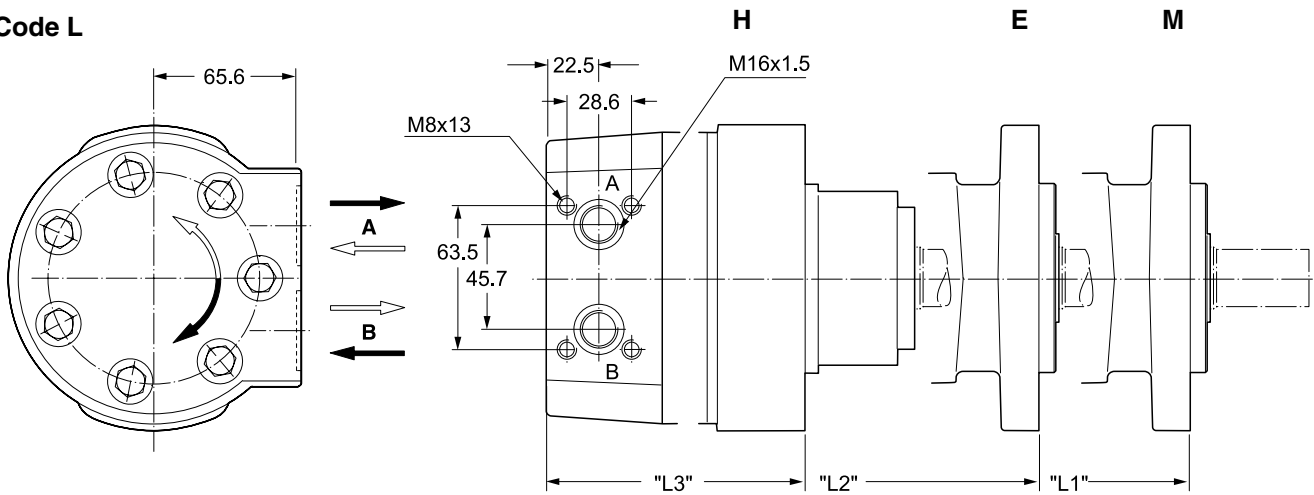

Code A 7/8-14UNF **Code Y** G 1/2

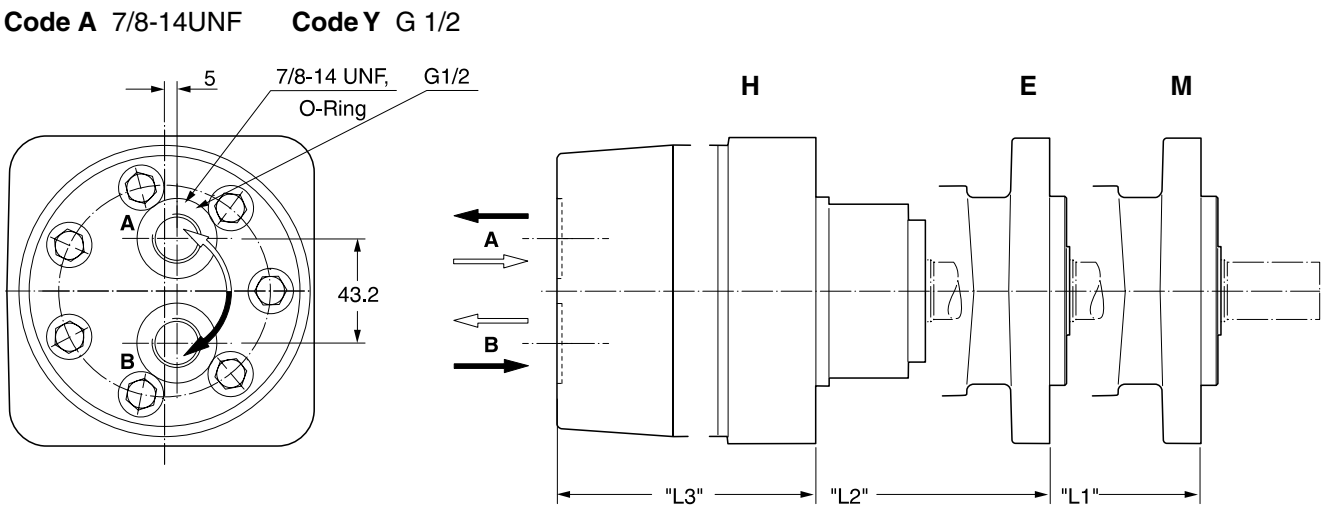

Gewicht / Weight	TG140	TG170	TG195	TG240	TG280	TG335	TG405	TG475	TG530	TG625	TG785	TG960
Poids / Peso [kg]	16.1	16.3	16.6	17.0	17.4	17.8	18.4	19.0	19.8	20.5	22.0	23.7
Code	"L1"[mm]	216	219	222	227	232	238	245	254	260	270	308
B, X, L,	"L2"[mm]	221	224	227	232	237	243	250	259	265	275	313
A, Y	"L3"[mm]	175	179	182	187	191	198	205	213	220	247	267

Code 44

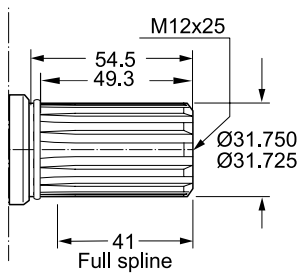

Involute spline
ANS B92.1-1970 Standard
Flat root side fit
Pitch 12/24
Teeth 14
Major diam. 1.25 in
Pressure angle 30°

Code 45

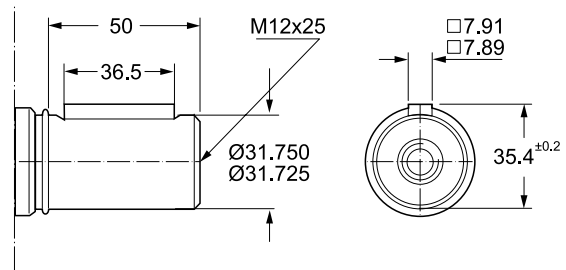

Code 08

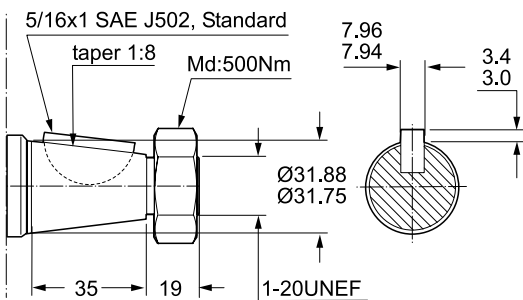

Code 46

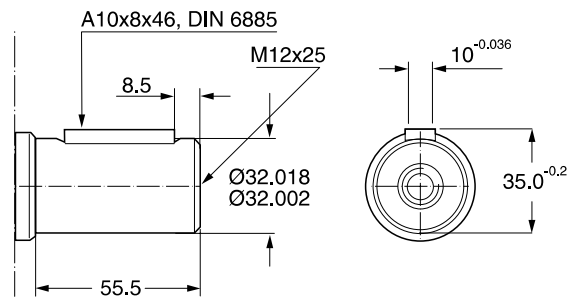

* On request shaft with 35mm diameter

Code 92

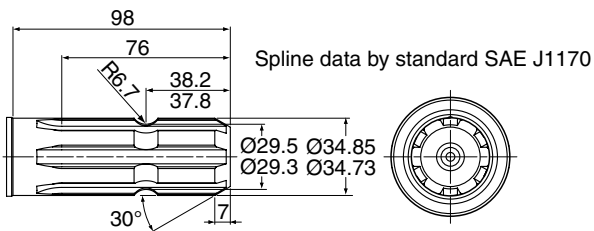

Code 94

A10x8x46, DIN 6885

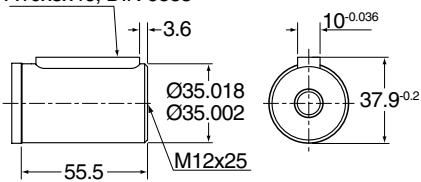

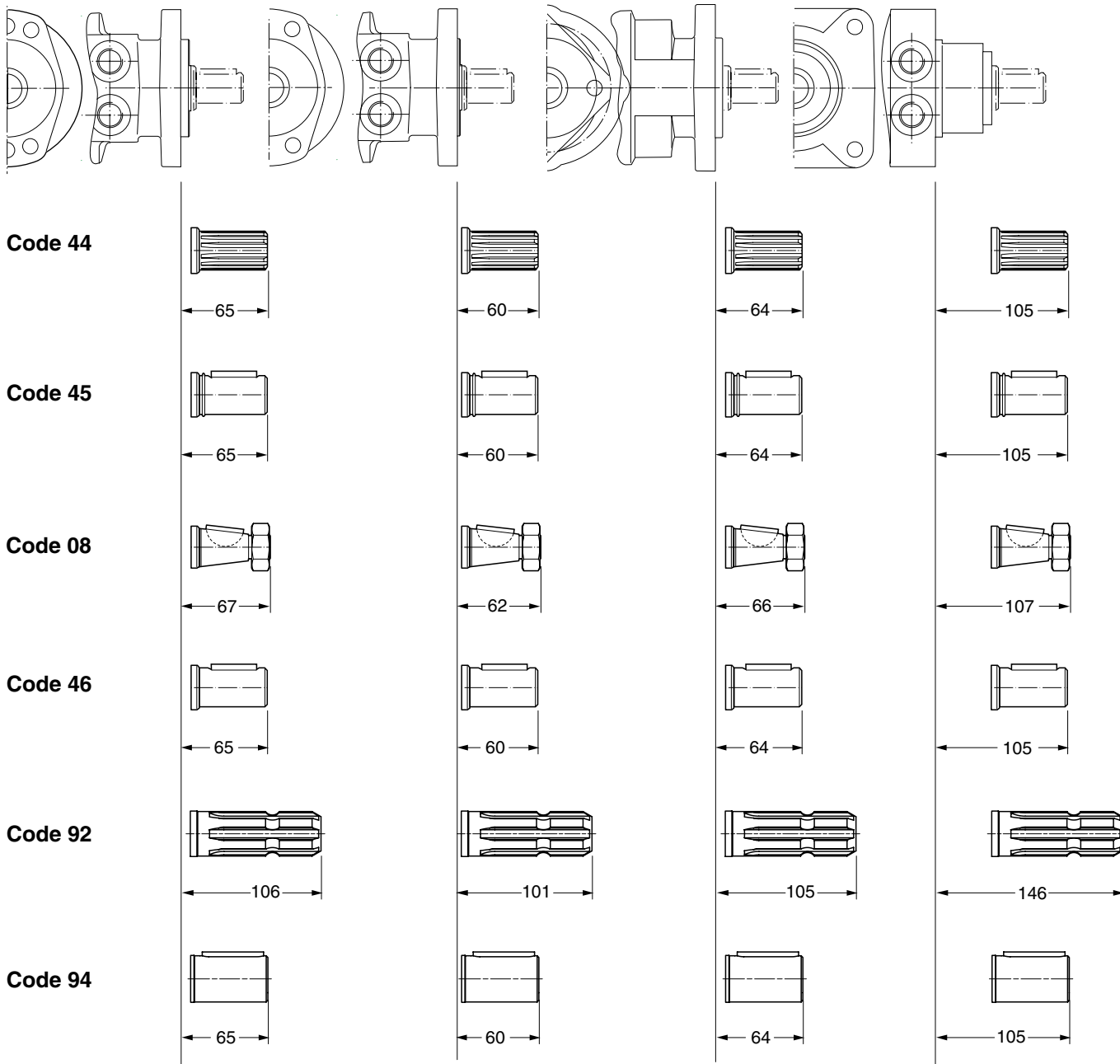

TG 140

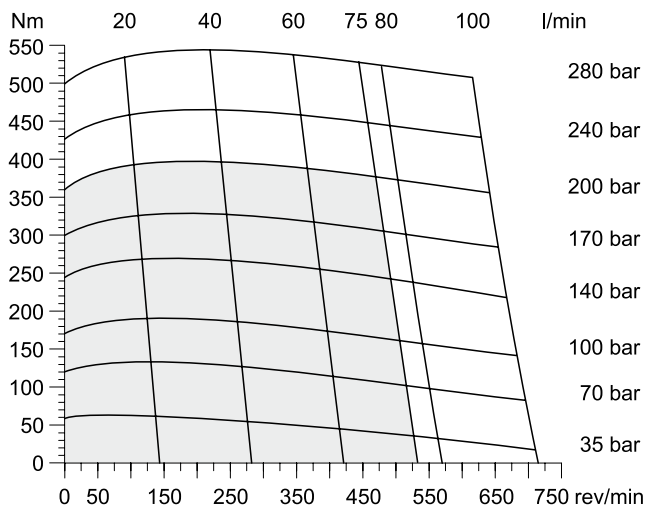

TG 170

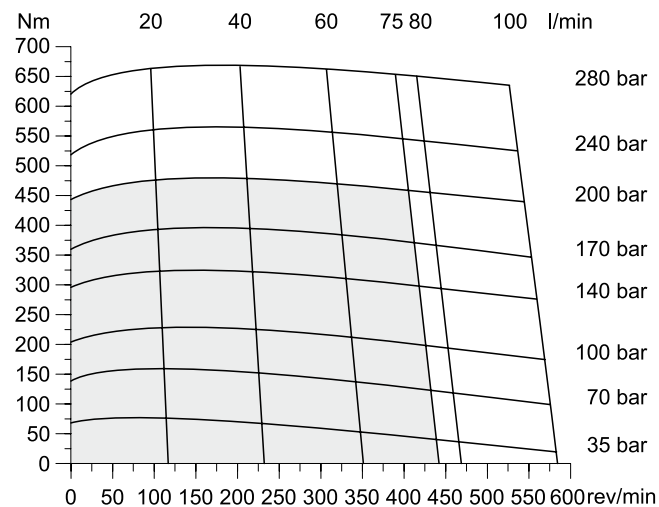

TG 195

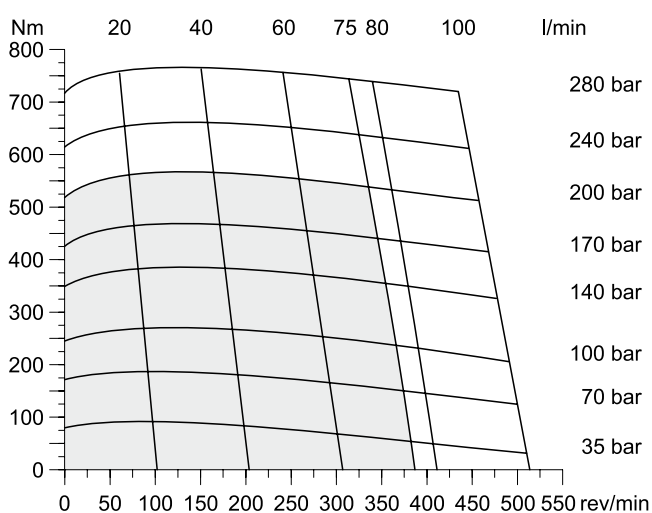

TG 240

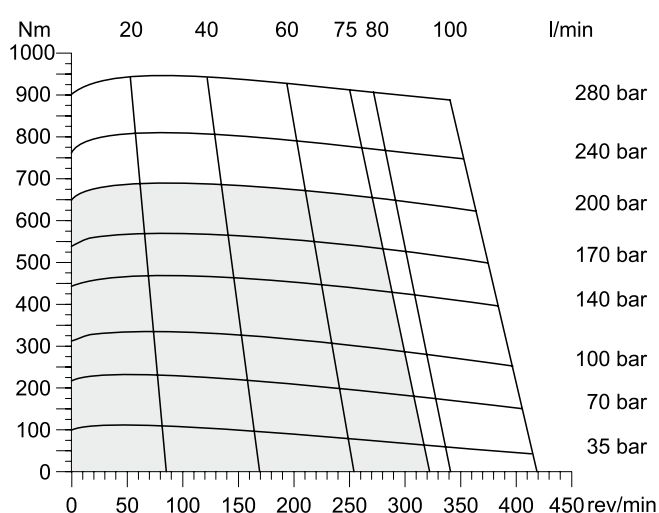

TG 280

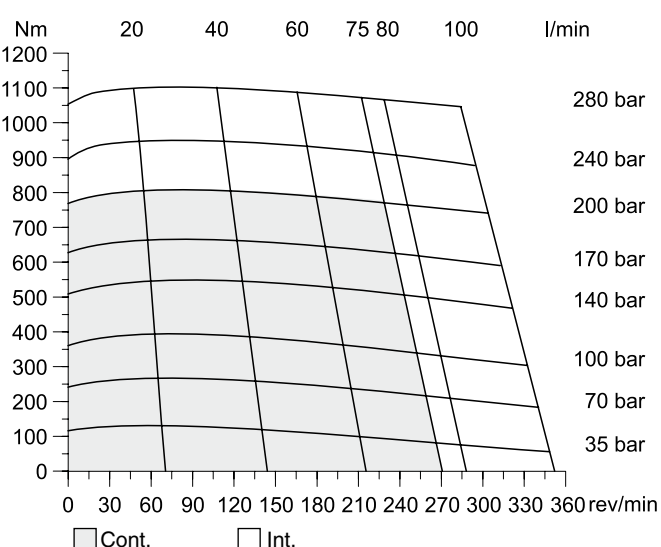

TG 335

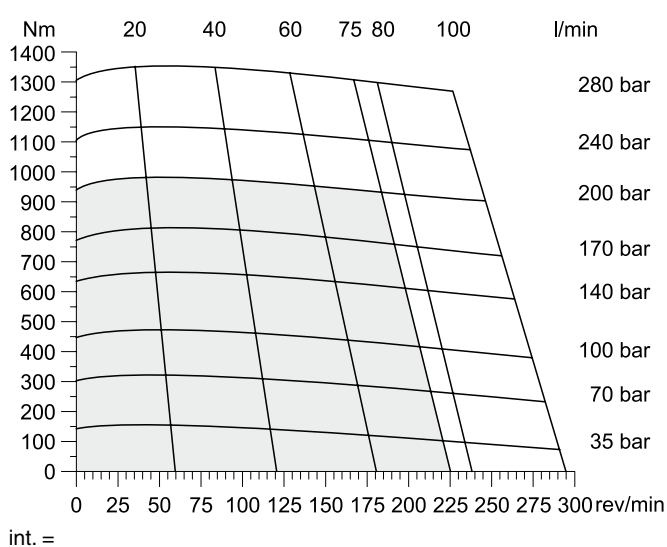

□ Cont. □ Int.

int. =
 Intermittierende Werte maximal: 10% von jeder Betriebsminute.
 Intermittent operation rating applies to 10% of every minute.
 Fonctionnement interm.: 10% max. de chaque minute d'utilisation.
 Servizio intermittente: 10% max di ogni minuto di utilizzazione.

TG 405

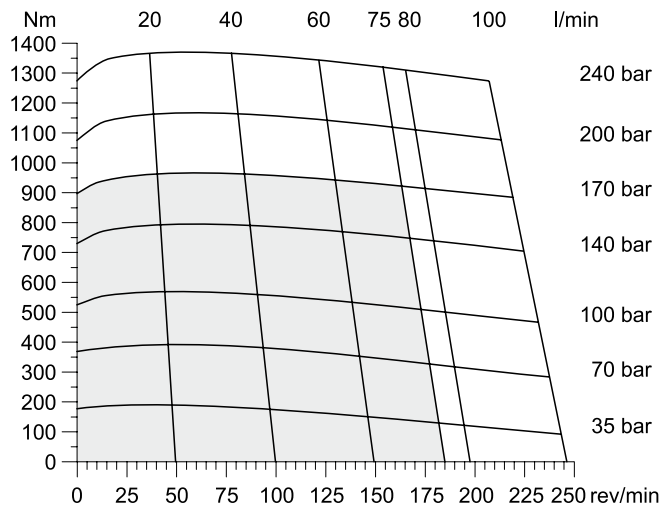

TG 475

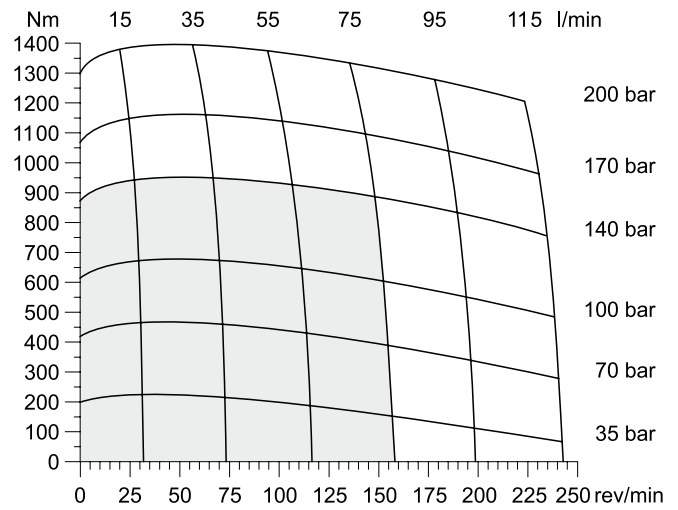

TG 530

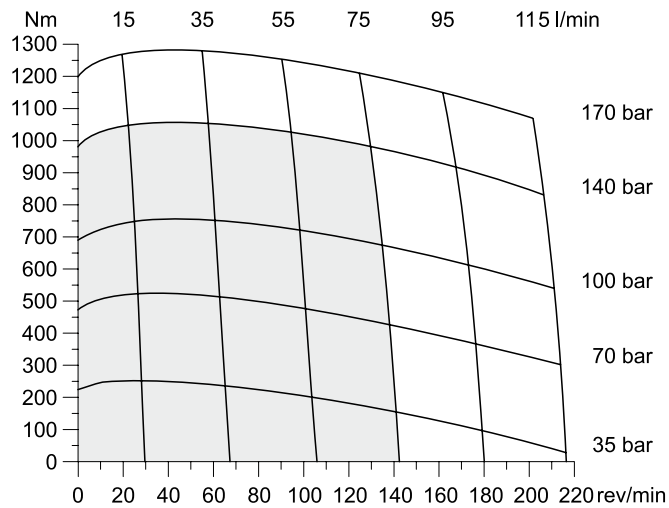

TG 625

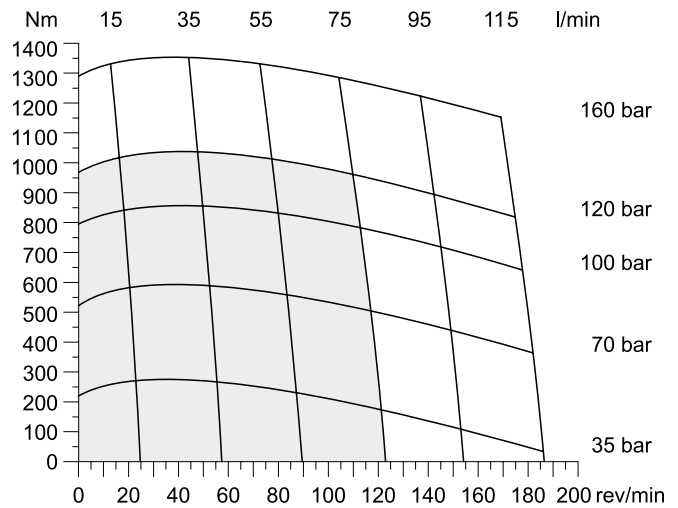

TG 785

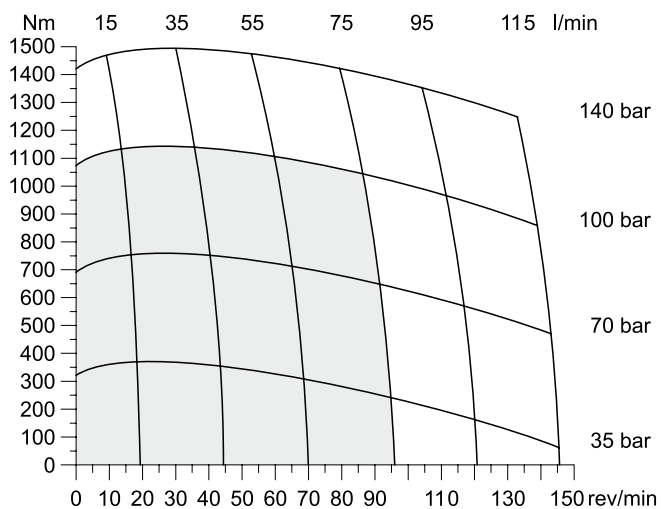

TG 960

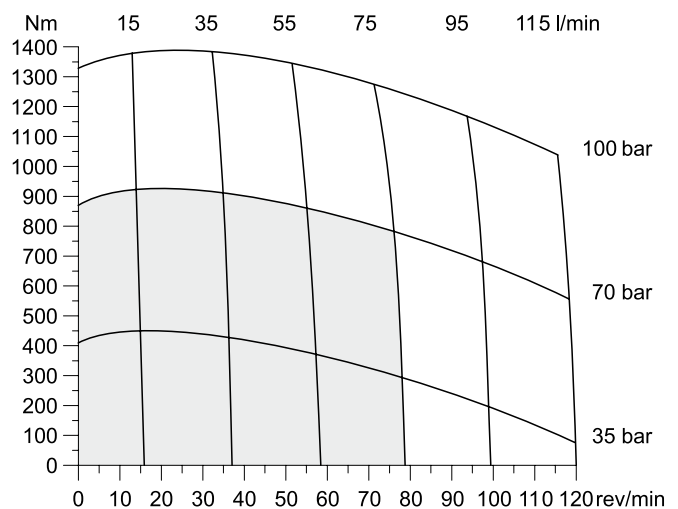

■ Cont. □ Int.

int. =
 Intermittierende Werte maximal: 10% von jeder Betriebsminute.
 Intermittent operation rating applies to 10% of every minute.
 Fonctionnement interm.: 10% max. de chaque minute d'utilisation.
 Servizio intermittente: 10% max di ogni minuto di utilizzazione.

Code E

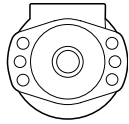

$$L_h = \frac{\left(\frac{670000}{F_R \cdot \left(1.10 + \frac{L}{88\text{mm}} \right)} \right)^{3.3}}{n}$$

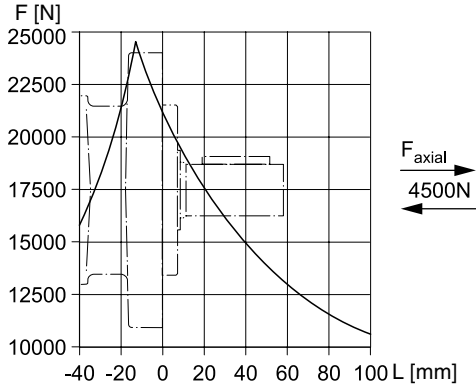

Code M

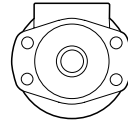

$$L_h = \frac{\left(\frac{670000}{F_R \cdot \left(1.16 + \frac{L}{88\text{mm}} \right)} \right)^{3.3}}{n}$$

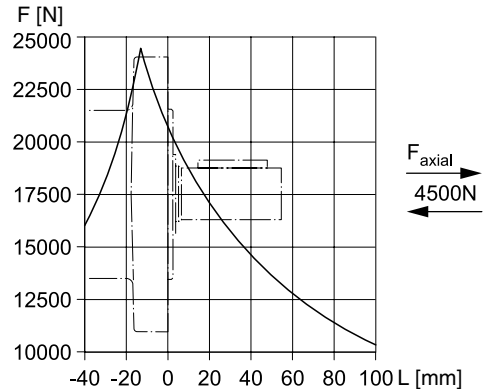

Code H

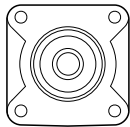

$$L_h = \frac{\left(\frac{670000}{F_R \cdot \left(0.56 + \frac{L}{88\text{mm}} \right)} \right)^{3.3}}{n}$$

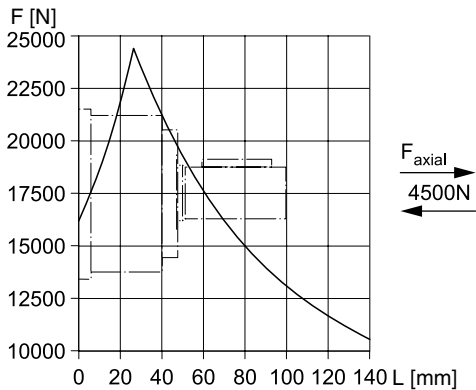

Code V

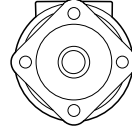

$$L_h = \frac{\left(\frac{670000}{F_R \cdot \left(1.11 + \frac{L}{88\text{mm}} \right)} \right)^{3.3}}{n}$$

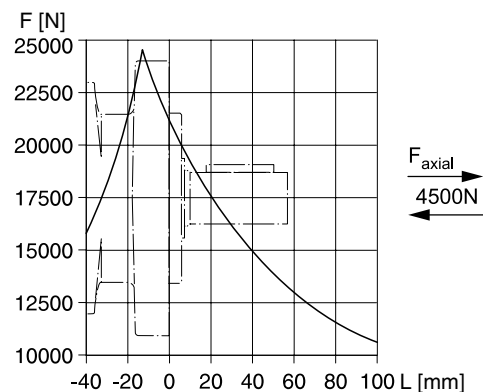

Die Lebensdauer der Radiallager (L_h in Stunden) lässt sich nach folgender Formel berechnen. Die Größe F_R ist durch die mechanische Festigkeit der Abtriebswelle begrenzt (siehe Diagramm). Das Maß "L" ist das Längenmaß vom Gehäuseflansch bis zum Angriffspunkt der Radialkraft F_R .

La durée de vie des roulements radiaux (L_h en heures) peut être calculée par les formules suivantes. La grandeur F_R est limitée par les résistances mécaniques de l'arbre de sortie (voir diagramme). La cote "L" est la longueur entre la bride du carter jusqu'à un point d'appui de l'effort radial F_R .

Life time (L_h in hours) of the radial bearings can be calculated with the following formula. The value F_R is limited by the mechanical strength of the shaft (see diagram). The measurement "L" is the length from the housing flange up to the point of impact of the radial force F_R .

La durata dei cuscinetti (L_h in ore) può essere calcolata con la seguente formula. Il valore F_R è limitato dalla resistenza meccanica dell'albero (vedi diagramma). La quota "L" è la distanza tra la flangia del corpo ed il punto di applicazione della forza radiale F_R .

Vorstehende Formeln gelten für eine B10-Lebensdauer.
 The preceding formulas are valid for a B10 duration of life.
 Les formules précédentes sont valables pour une durée de vie B10.
 Le formule precedenti sono valide per una durata della vita B10.

- L_h = [h]
- L = [mm]
- F_R = F [N]
- n = [rev/min]

Torqmotor Series TG

Ordering Code

TG

A A A B

Serie
Series
Série
Serie

Schluckvolumen
Displacement
Cylindrée
Cilindrata

Gehäuse
Housing
Carter
Corpo motore

Anschluss
Ports
Plan de raccorde-
ment
Conessioni

Welle
Shaft
Arbre
Albero

Drehrichtung
Direction of rotation
Direction de rotation
Direzione di rotazione

Option

For further options
different to standard
'AAAB' see page 57.

Code	cm ³ /rev
0140	140
0170	169
0195	195
0240	237
0280	280
0335	337
0405	405
0475	476
0530	529
0625	624
0785	786
0960	958

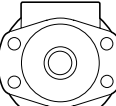
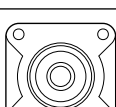
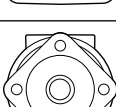
Code	Housing
E	
M	
H	
V ¹⁾	



Code	Front port
W	G 1/2
V	7/8-14 UNF O-Ring
N ²⁾	Universal M8x13
K ³⁾	Universal M6x13

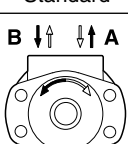

²⁾ Nicht verfügbar für Gehäuse "H"
Not possible for housing "H"
Pas disponible pour carter "H"
Non Disponibile con il corpo codice "H"
³⁾ Nicht verfügbar für Gehäuse "M, E, V"
Not possible for housing "M, E, V"
Pas disponible pour carter "M, E, V"
Non disponibile con il corpo codice "M, E, V"

Code	Rear port
Y	G 1/2 Axial
A	7/8-14 UNF Axial
X	G 1/2 Radial
B	7/8-14 UNF Radial
L	Universal Radial M8x13

¹⁾ Nur verfügbar mit Endanschluss
Only possible with rear port
Possible seulement avec orifice arrière
Possible solo con connessioni posteriori

Code	Front port
0	 Standard
1	 Standard

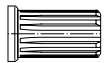
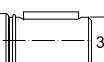
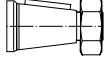
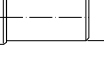
Code	Rear port
0	 Standard
1	 Standard

Code	Shaft
44	 Pitch 12/24
45	 31.75
08	
46	 32
92	 34.85
94	 35

- **Langsamlaufender Gerotor-Motor**
 - **Spezielle Orbital-Steuerung**
Geringe interne Leckage
Hoher volumetrischer Wirkungsgrad
 - **Rollen im Rotorsatz**
Reduzierte Reibung
Lange Lebensdauer
 - **Patentierter Hochdruckwellendichtung**
Keine Leckölleitung
Keine Rückschlagventile
 - **Vielzahl von Varianten**
Großer Einsatzbereich
-
- **Moteur lent système Gerotor**
 - **Une distribution orbitale particulière assurée**
fuites internes minimales
rendements volumétriques élevés
 - **Le rotor à rouleaux**
réduit les frottements
augmente la durée de vie
 - **Par l'utilisation de joints d'arbre haute pression brevetés**
pas de conduite de drainage
pas de clapets anti-retour
 - **Grâce à de nombreuses variantes**
larges domaines d'application
-
- **Low Speed Gerotor Motor**
 - **Zero leak commutation valve**
For greater, more consistent volumetric efficiency
 - **Roller vane rotor set**
Reduces friction and internal leakage
Maintaining efficiency throughout the life of the motor
 - **A patented high-pressure shaft seal**
No check valves needed
No extra plumbing
 - **Wide choice of displacement range, flange and shaft options**
Greater efficiency in systems design to suit your application
-
- **Motore orbitale a bassa velocità**
 - **Una particolare distribuzione orbitale assicurata**
trafilamento ridotto
elevato rendimento volumetrico
 - **Con lo statore a rullini**
si riduce l'attrito interno
si mantiene nel tempo l'efficienza del motore
 - **Una guarnizione di tenuta ad alta pressione brevettata elimina la necessità**
di una linea di drenaggio esterna
e di valvole di non ritorno
 - **Un'ampia gamma di cilindrate, flange ed alberi**
consentono scelte adeguate ad ogni esigenza costruttiva

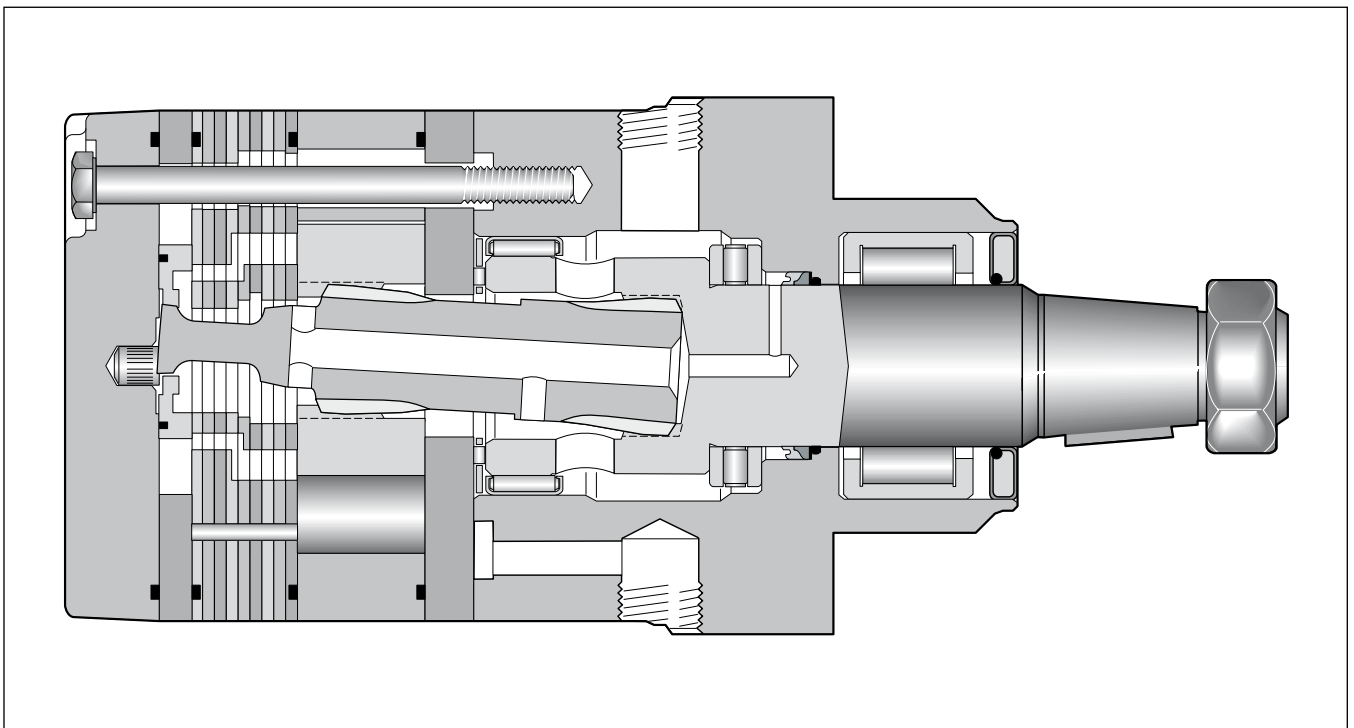

Performance

Drehzahl Speed Vitesse de rotation Velocità di rotazione	5...710 rev/min
Schluckstrom Oil flow Débit d'huile Portata	max. 115 l/min
Eingangsdruck Supply pressure Pression entrée Pressione in entrata	max. 300 bar
Drehmoment Torque Couple Coppia	max. 1490 Nm
Seitenlast Side load Charges latérales Carico radiale	max. 30.000 N

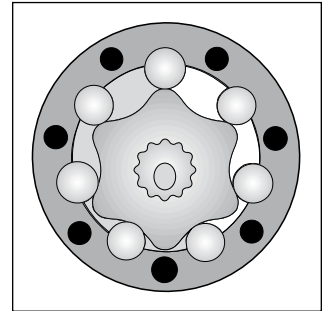
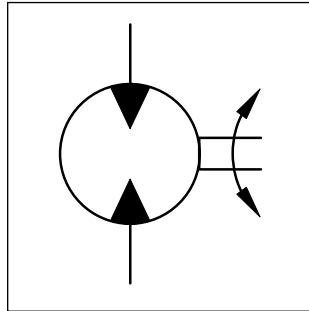

Motor series TF	Geom. Schluckvolumen Geometric displacement Cylindrée Cilindrata	Max. Drehzahl Max. speed Vitesse de rotation maxi Velocità di rotazione maxi	Max. Schluckstrom Max. oil flow Portata max	Max. Druckdifferenz * Max. differential pressure * Chute de pression maxi * Caduta di pressione max *	Max. Eingangsdruck Max. supply pressure Pression maxi entrée Pressione max in entrata	Max. Drehmoment Max. torque Couple maxi Coppia max	Max. Leistungabgabe Max. performance Puissance de sortie maxi Potenza meccanica max	Min. Anlaufmoment Min. starting torque Couple min. de démarrage Coppia min. di spunto
	[cm ³ /U] [cm ³ /rev]	cont / int [U/min] [rev/min]	cont / int [l/min]	cont / int [bar]	max [bar]	cont / int [Nm]	cont / int [KW]	cont / int [Nm]
TH 140	141	530/710	75/100	210/280	300	400/545	33	320/436
TH 170	169	440/575	75/100	210/280	300	485/670	33	388/536
TH 195	195	380/510	75/100	210/280	300	560/770	33	448/616
TH 240	238	320/420	75/100	210/280	300	685/945	32	548/756
TH 280	280	270/350	75/100	210/280	300	800/1100	31	675/880
TH 335	337	225/290	75/100	210/280	300	980/1350	30	784/1080
TH 405	405	185/245	75/100	170/240	300	960/1350	27	791/1145
TH 475	477	160/240	75/115	140/210	300	960/1400	28	768/1120
TH 530	529	140/215	75/115	140/170	300	1050/1280	23	874/1091
TH 625	613	120/185	75/115	120/160	300	1040/1360	20	895/1165
TH 785	786	95/145	75/115	100/140	300	1150/1490	17	991/1341
TH 960	959	78/119	75/115	70/100	300	925/1390	12	763/1177

int. =
Intermittierende Werte maximal: 10% von jeder Betriebsminute.
Intermittent operation rating applies to 10% of every minute.
Fonctionnement interm.: 10% max. de chaque minute d'utilisation.
Servizio intermittente: 10% max di ogni minuto di utilizzazione.

- * Druckdifferenz Δp zwischen Ein- und Ausgang
- * Pressure difference is Δp between input and output
- * La différence de pression est Δp entre l'entrée et la sortie
- * La differenza di pressione corrisponde al Δp tra ingresso e uscita

Achtung: Höhere Drücke auf Anfrage möglich.
Notice: Higher pressures are possible on request.
Remarque : des pressions supérieures sont possibles sur demande.
Nota: Pressioni superiori possibili su richiesta.

Code M

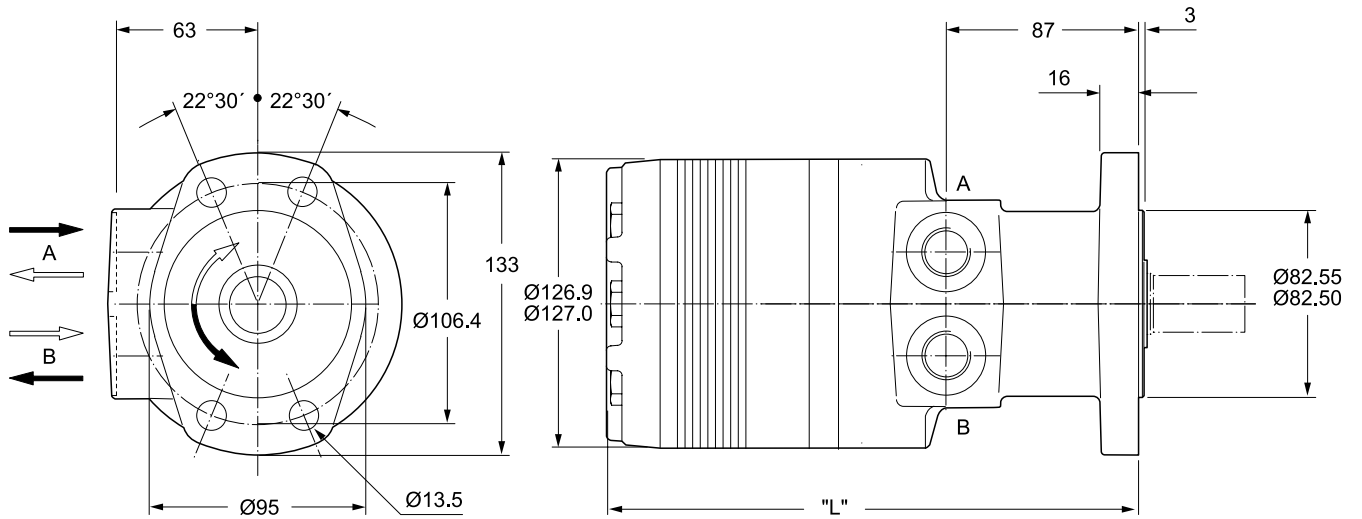

Code U

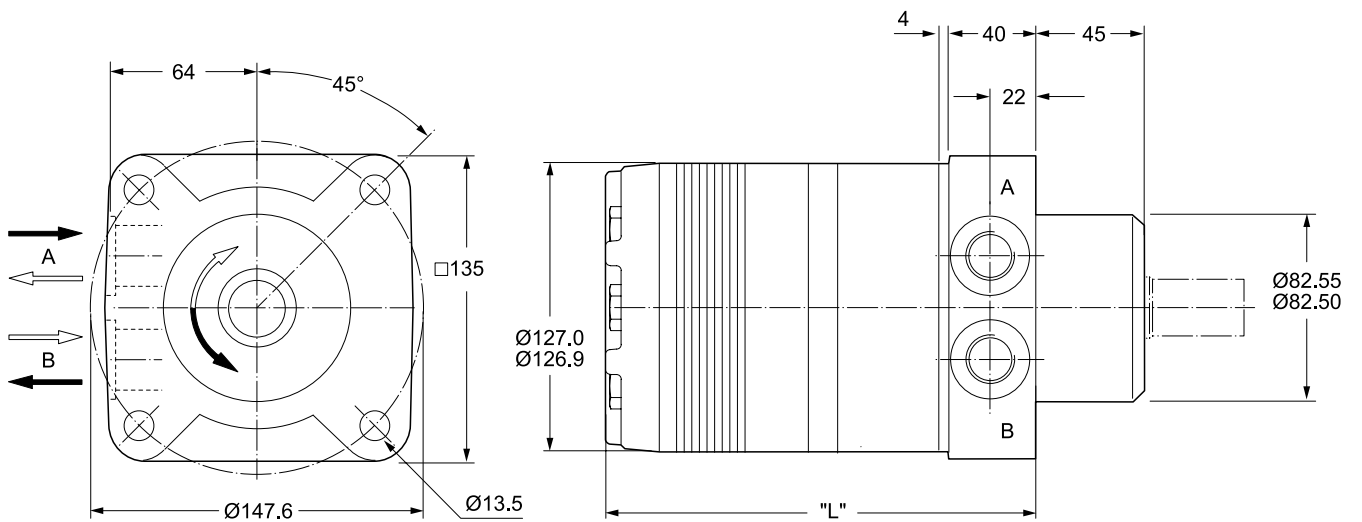

Gewicht / Weight Poids / Peso [kg]	TH140	TH170	TH195	TH240	TH280	TH335	TH405	TH475	TH530	TH625	TH785	TH960	
		17.0	17.2	17.4	17.8	18.2	18.6	19.2	19.8	20.6	21.3	22.9	24.5
Code M	"L" [mm]	216	219	222	227	232	238	245	254	260	270	289	308
Code U	"L" [mm]	173	177	180	184	189	196	203	212	218	227	246	265

Ports

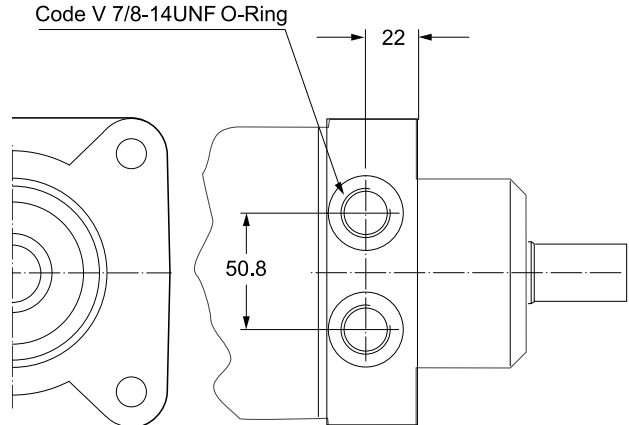
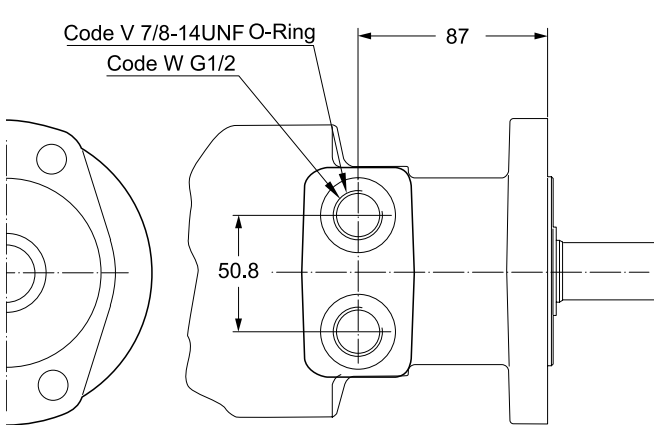

**Coupling shaft
 Code 31**

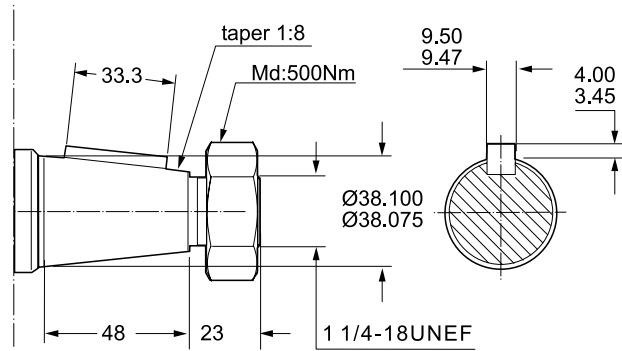

Code 32

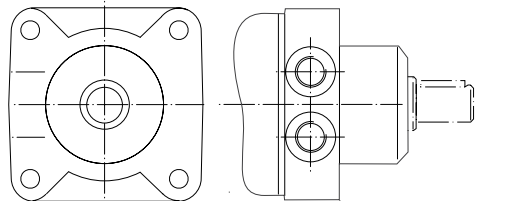
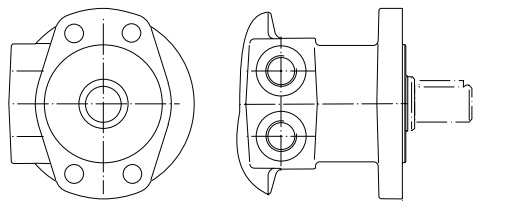
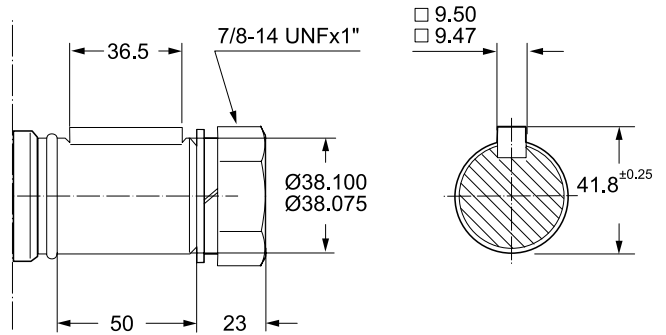

Code 31

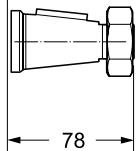

Code 32

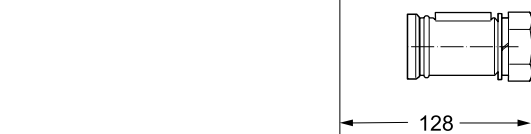
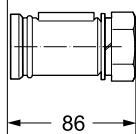

Code B 7/8-14UNF **Code X** G 1/2

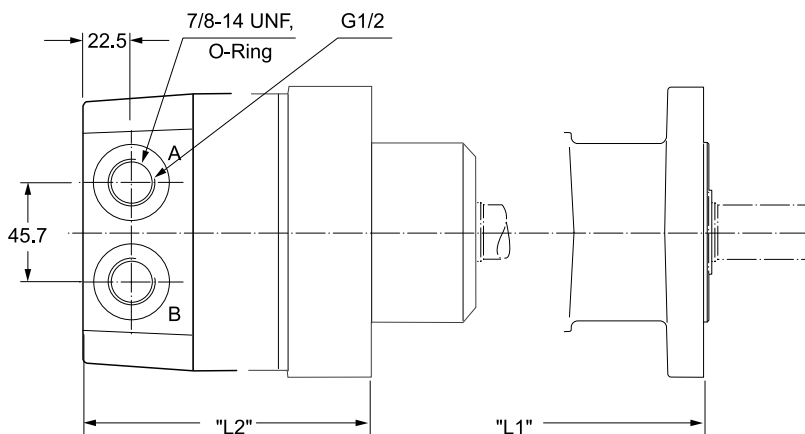
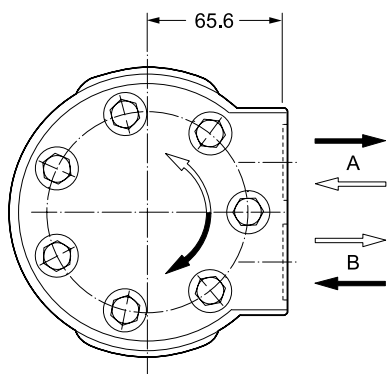

Code A 7/8-14UNF **Code Y** G 1/2

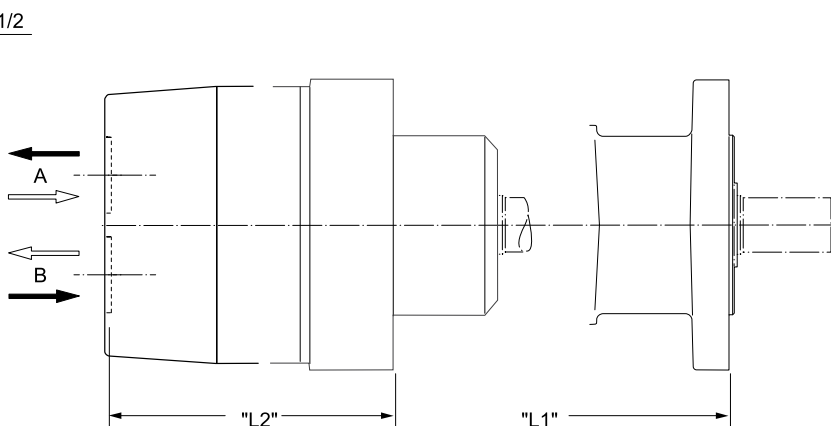
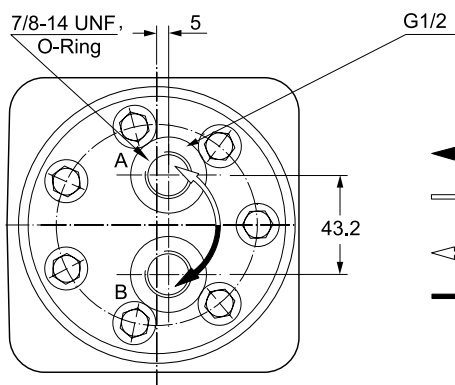

Code L

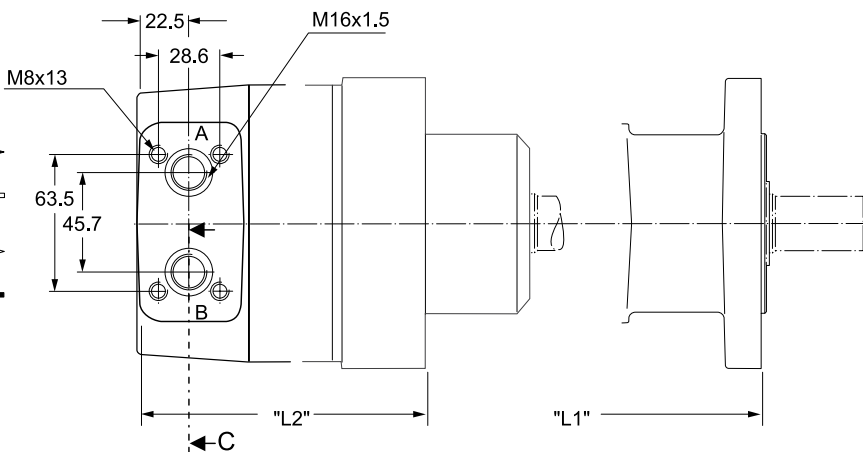
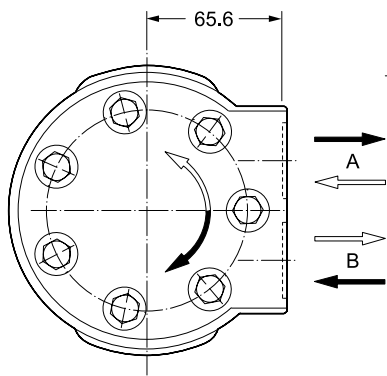

Section C

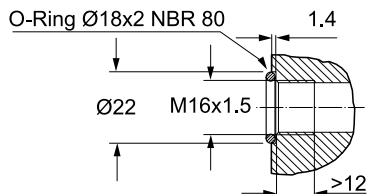

Zum Motor mit Universalanschluss werden 2 O-Ringe geliefert.

Motor with manifold mount is supplied with 2 O-rings.

Deux joints toriques sont livrés avec les moteurs au plan de raccordement universel.

Il blocchetto connessioni è corredato da 2 OR.

Gewicht / Weight Poids / Peso [kg]		TH140	TH170	TH195	TH240	TH280	TH335	TH405	TH475	TH530	TH625	TH785	TH960
		18.6	18.8	19.0	19.4	19.8	20.2	20.8	21.4	22.2	22.9	24.5	26.1
Code	"L1" [mm]	241	244	247	252	257	263	270	279	285	295	314	333
B, X, L, A, Y	"L2" [mm]	198	202	205	209	214	221	228	237	243	252	271	290

TH 140

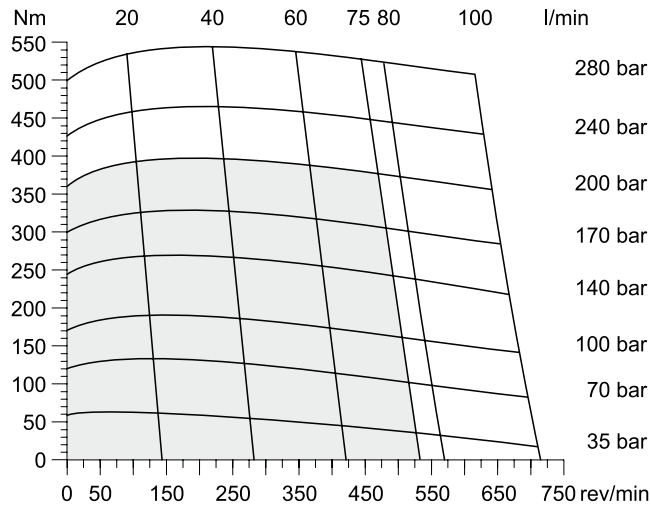

TH 170

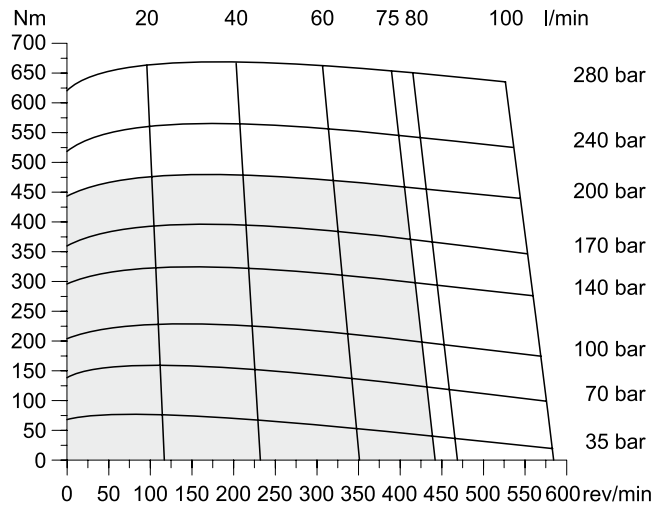

TH 195

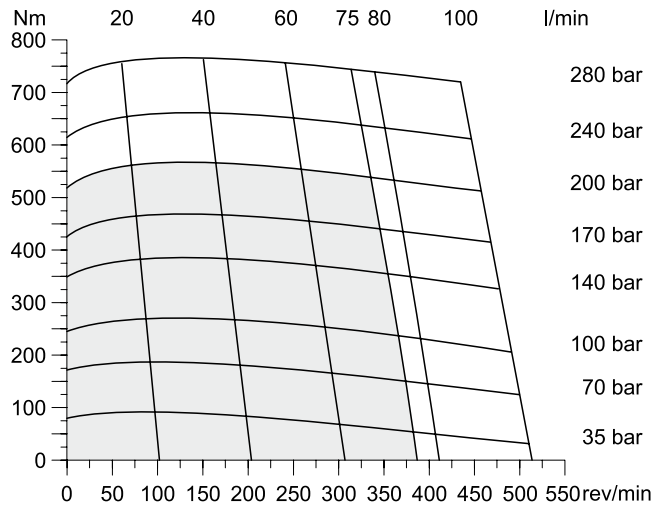

TH 240

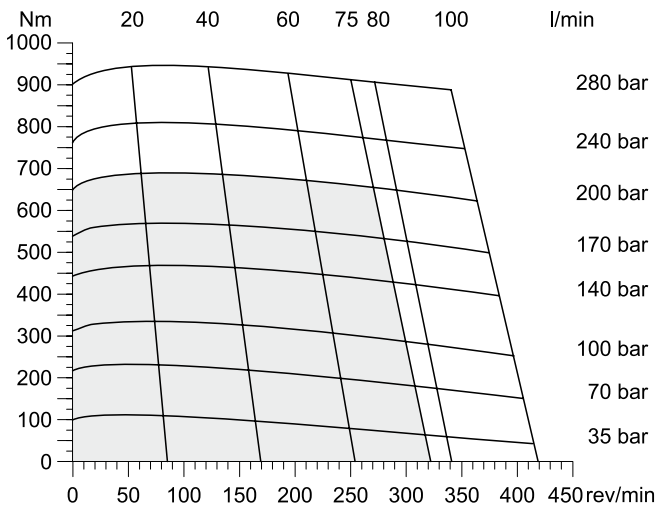

TH 280

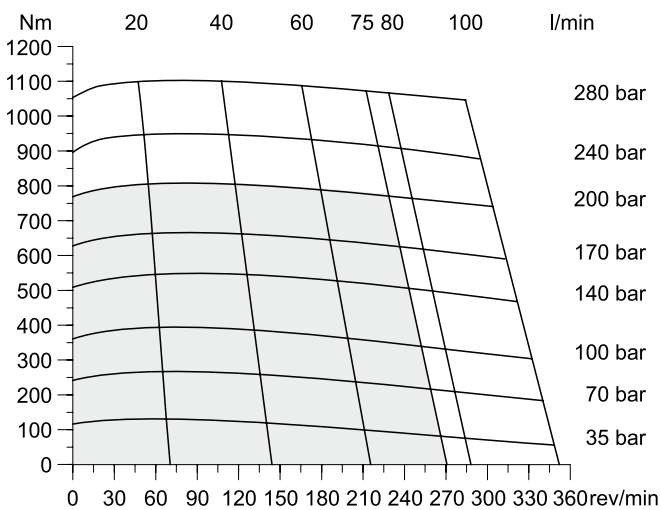

TH 335

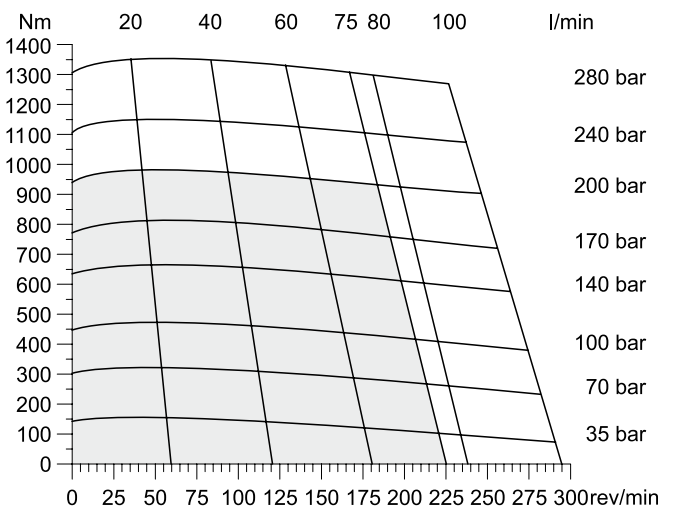

□ Cont. □ Int.

int. =
Intermittierende Werte maximal: 10% von jeder Betriebsminute.
Intermittent operation rating applies to 10% of every minute.
Fonctionnement interm.: 10% max. de chaque minute d'utilisation.
Servizio intermittente: 10% max di ogni minuto di utilizzazione.

TH 405

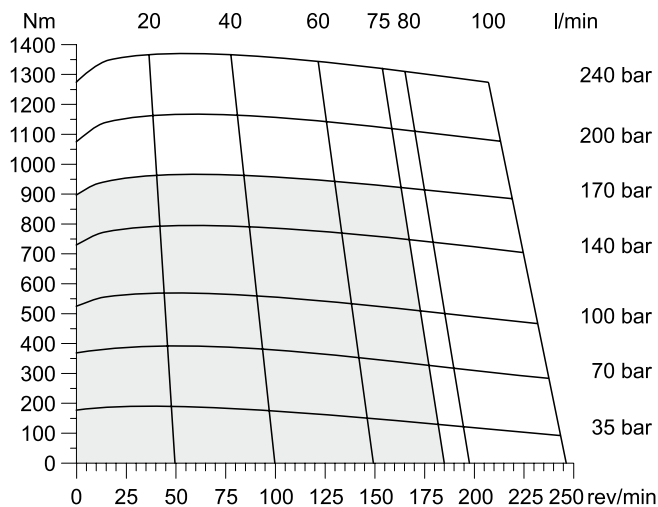

TH 475

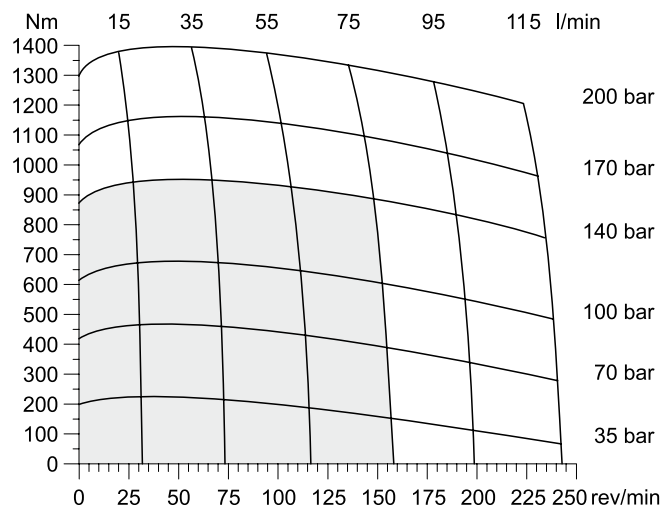

TH 530

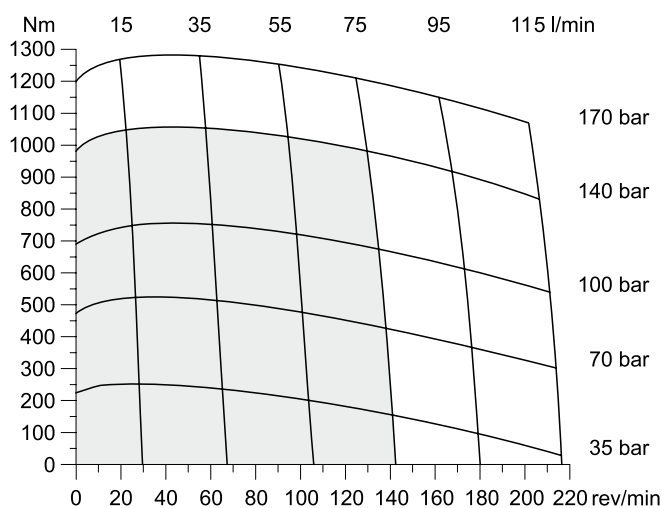

TH 625

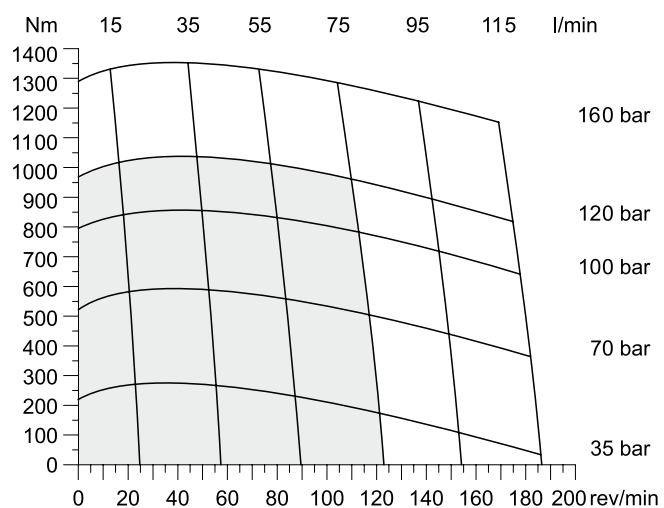

TH 785

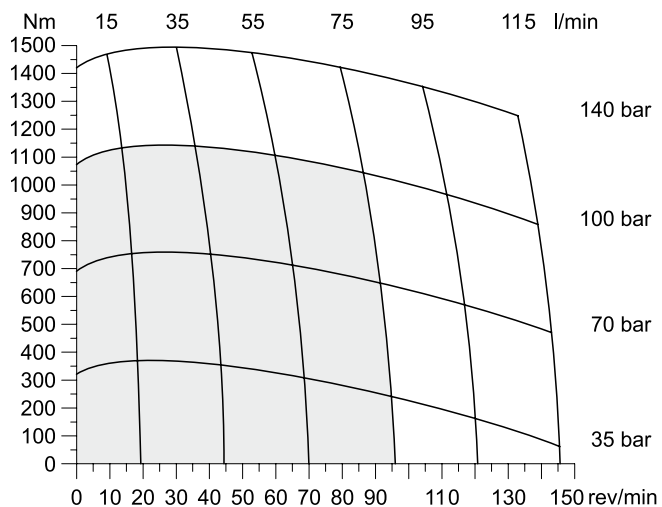

TH 960

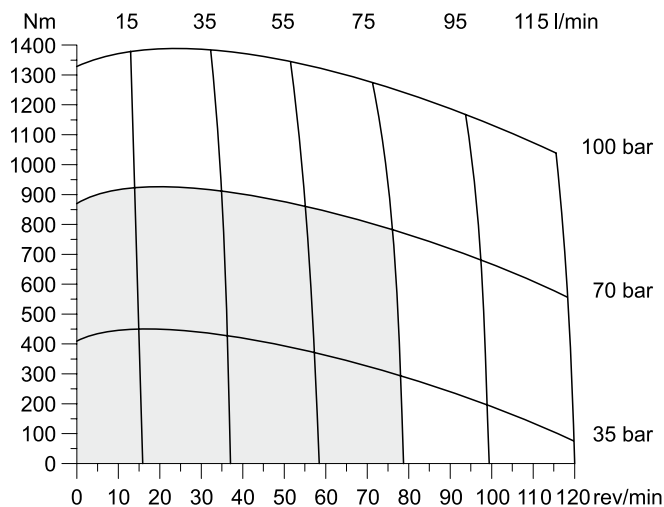

□ Cont. □ Int.

int. =
Intermittierende Werte maximal: 10% von jeder Betriebsminute.
Intermittent operation rating applies to 10% of every minute.
Fonctionnement interm.: 10% max. de chaque minute d'utilisation.
Servizio intermittente: 10% max di ogni minuto di utilizzazione.

Life Time

Code M

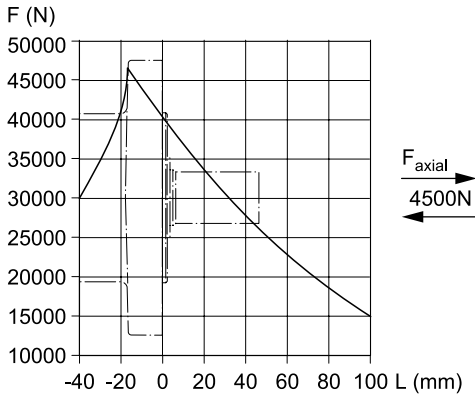

F_{Radial} [N]

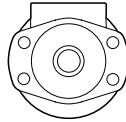

$$L_h = \frac{\left(\frac{1500000}{F_R \cdot \left(1.20 + \frac{L}{95\text{mm}} \right)} \right)^{3.3}}{n}$$

Code U

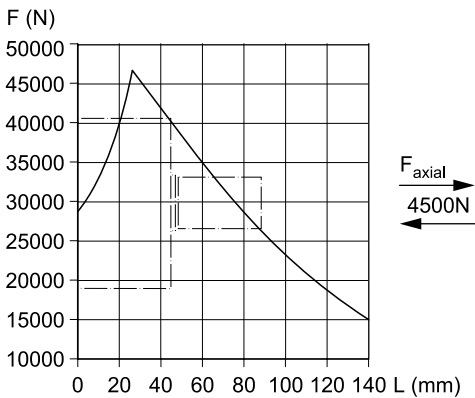

F_{Radial} [N]

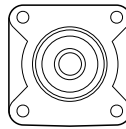

$$L_h = \frac{\left(\frac{1500000}{F_R \cdot \left(0.76 + \frac{L}{95\text{mm}} \right)} \right)^{3.3}}{n}$$

Die Lebensdauer der Radiallager (L_h in Stunden) lässt sich nach folgender Formel berechnen. Die Größe F_R ist durch die mechanische Festigkeit der Abtriebswelle begrenzt (siehe Diagramm). Das Maß "L" ist das Längenmaß vom Gehäuseflansch bis zum Angriffspunkt der Radialkraft F_R .

La durée de vie des roulements radiaux (L_h en heures) peut être calculée par les formules suivantes. La grandeur F_R est limitée par les résistances mécaniques de l'arbre de sortie (voir diagramme). La cote "L" est la longueur entre la bride du carter jusqu'au point d'appui de l'effort radial F_R .

Life time (L_h in hours) of the radial bearings can be calculated with the following formula. The value F_R is limited by the mechanical strength of the shaft (see diagram). The measurement "L" is the length from the housing flange up to the point of impact of the radial force F_R .

La durata dei cuscinetti (L_h in ore) può essere calcolata con la seguente formula. Il valore F_R è limitato dalla resistenza meccanica dell'albero (vedi diagramma). La quota "L" è la distanza tra la flangia del corpo ed il punto di applicazione della forza radiale F_R .

Vorstehende Formeln gelten für eine B10-Lebensdauer.
The preceding formulas are valid for a B10 duration of life.
Les formules précédentes sont valables pour une durée de vie B10.
Le formule precedenti sono valide per una durata della vita B10.

L_h = [h]
 L = [mm]
 n = [rev/min]

Ordering Code

Torqmotor Series TH

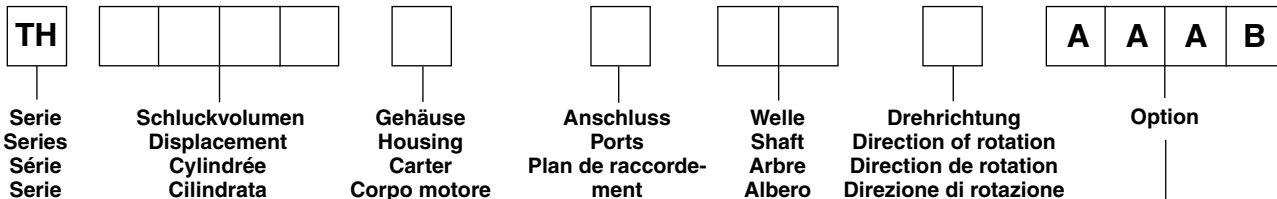

Code	cm ³ /rev
0140	140
0170	169
0195	195
0240	237
0280	280
0335	337
0405	405
0475	476
0530	529
0625	624
0785	786
0960	958

Code	Housing
M	
U	

Code	Front port
S	7/8-14 UNF O-Ring
W ¹⁾	G 1/2

¹⁾ Nicht verfügbar für Gehäuse "U"
 Not possible for housing "U"
 Pas disponible pour carter "U"
 Non Disponibile con il corpo codice "U"

Code	Rear port
Y	G 1/2 Axial
A	7/8-14 UNF Axial
X	G 1/2 Radial
B	7/8-14 UNF Radial
L	Universal Radial M8x13

Code	Shaft
31	
32	

For further options different to standard 'AAAB' see page 57.

Code	Front port
0	 Standard
1	

Code	Rear port
0	 Standard
1	

- **Langsamlaufender Gerotor-Motor**
 - **Spezielle Orbital-Steuerung**
Geringe interne Leckage
Hoher volumetrischer Wirkungsgrad
 - **Rollen im Rotoratz**
Reduzierte Reibung
Lange Lebensdauer
 - **Patentierter Hochdruckwellendichtung**
Keine Leckölleitung
Keine Rückschlagventile
 - **Vielzahl von Varianten**
Großer Einsatzbereich
- **Low Speed Gerotor Motor**
 - **Zero leak commutation valve**
For greater, more consistent volumetric efficiency
 - **Roller vane rotor set**
Reduces friction and internal leakage
Maintaining efficiency throughout the life of the motor
 - **A patented high-pressure shaft seal**
No check valves needed
No extra plumbing
 - **Wide choice of displacement range, flange and shaft options**
Greater efficiency in systems design to suit your application
- **Moteur lent système Gerotor**
 - **Une distribution orbitale particulière assure**
fuites internes minimales
rendements volumétriques élevés
 - **Le rotor à rouleaux**
réduit les frottements
augmente la durée de vie
 - **Par l'utilisation de joints d'arbre haute pression brevetés**
pas de conduite de drainage
pas de clapets anti-retour
 - **Grâce à de nombreuses variantes**
larges domaines d'application
- **Motore orbitale a bassa velocità**
 - **Una particolare distribuzione orbitale assicura**
trafilamento ridotto
elevato rendimento volumetrico
 - **Con lo statore a rullini**
si riduce l'attrito interno
si mantiene nel tempo l'efficienza del motore
 - **Una guarnizione di tenuta ad alta pressione brevettata elimina la necessità**
di una linea di drenaggio esterna
e di valvole di non ritorno
 - **Un'ampia gamma di cilindrata, flange ed alberi**
consentono scelte adeguate ad ogni esigenza costruttiva

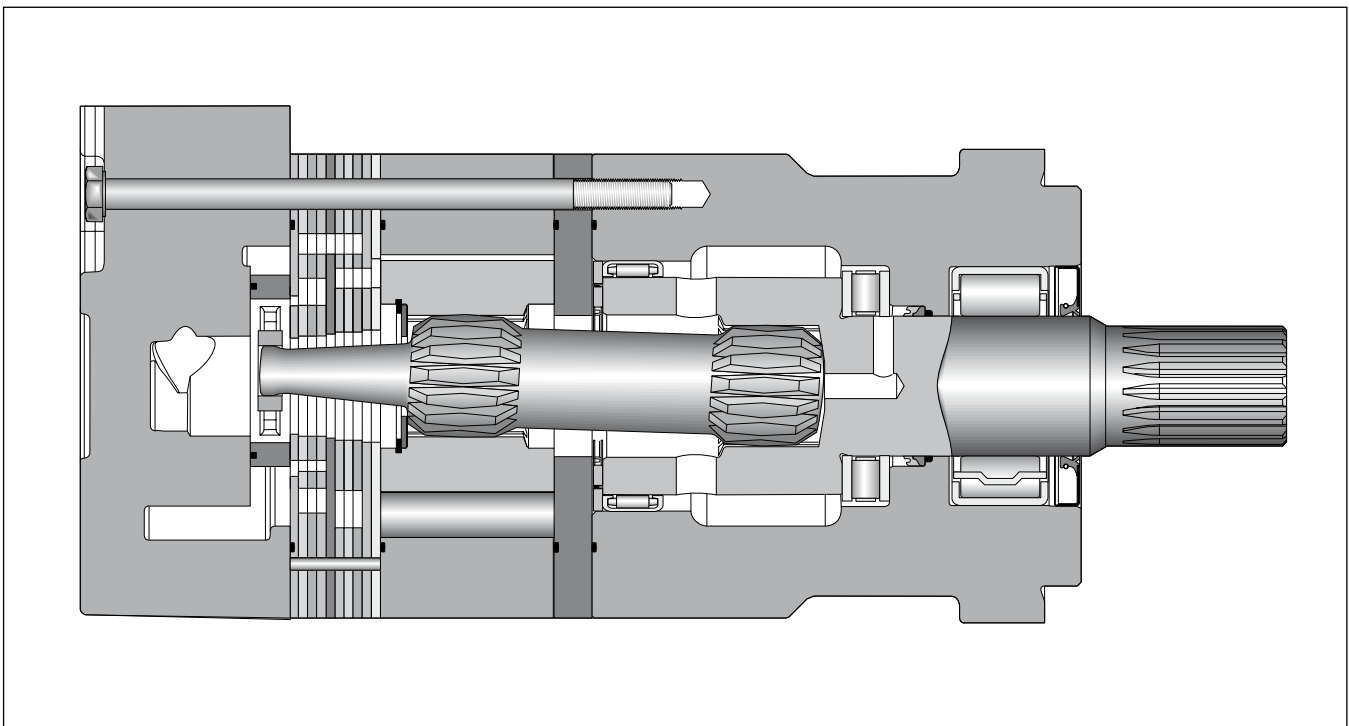

Performance

Drehzahl Speed Vitesse de rotation Velocità di rotazione	5...520 rev/min
Schluckstrom Oil flow Débit d'huile Portata	max. 225 l/min
Eingangsdruck Supply pressure Pression entrée Pressione in entrata	max. 330 bar
Drehmoment Torque Couple Coppia	max. 2700 Nm
Seitenlast Side load Charges latérales Carico radiale	max. 26.000 N

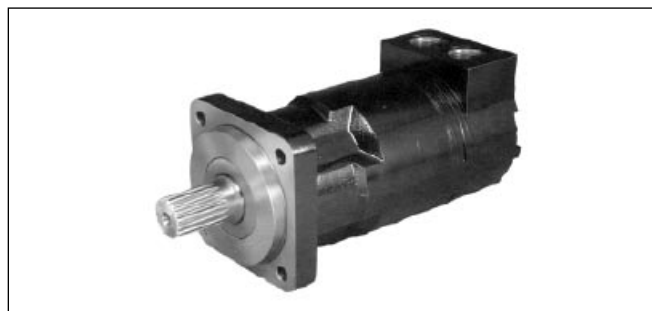
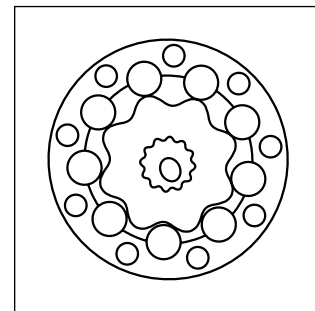
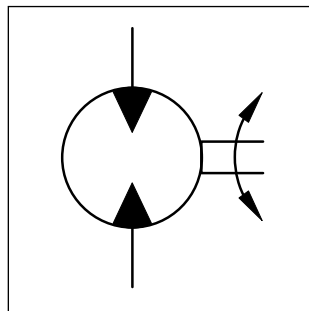

Motor series TF	Geom. Schluckvolumen Geometric displacement Cylindrée Cilindrata	Max. Drehzahl Max. speed Vitesse de rotation maxi Velocità di rotazione max	Max. Schluckstrom Max. oil flow Débit d'huile max Portata max	Max. Druckdifferenz * Max. differential pressure * Chute de pression maxi * Caduta di pressione max *	Max. Eingangsdruck Max. supply pressure Pression maxi entrée Pressione max in entrata	Max. Drehmoment Max. torque Couple maxi Coppia max	Max. Leistungabgabe Max. performance Puissance de sortie maxi Potenza meccanica max	Min. Anlaufmoment Min. starting torque Couple min. fourni au dé manrage Coppia min. di spunto
	[cm ³ /U] [cm ³ /rev]	cont / int [U/min] [rev/min]	cont / int [l/min]	cont / int [bar]	max [bar]	cont / int [Nm]	cont / int [KW]	cont / int [Nm]
TK 250	250	523	114/133	240/310	330	815/1043	49	690/880
TK 315	315	413	114/133	240/310	330	1030/1315	47	950/1220
TK 400	400	373	114/151	205/275	330	1150/1525	49	1050/1410
TK 500	500	300	114/151	205/275	330	1440/1915	48	1320/1780
TK 630	630	240	114/151	205/225	330	1620/1715	34	1500/1620
TK 800	800	276	151/227	190/205	330	1915/2300	44	1740/1900
TK 1000	1000	220	151/227	175/190	330	2410/2660	35	1980/2180

int. =

Intermittierende Werte maximal: 10% von jeder Betriebsminute.

Intermittent operation rating applies to 10% of every minute.

Fonctionnement interm.: 10% max. de chaque minute d'utilisation.

Servizio intermittente: 10% max di ogni minuto di utilizzazione.

- * Druckdifferenz Δp zwischen Ein- und Ausgang
- * Pressure difference is Δp between input and output
- * La différence de pression est Δp entre l'entrée et la sortie
- * La differenza di pressione corrisponde al Δp tra ingresso e uscita

Achtung: Höhere Drücke auf Anfrage möglich.

Notice: Higher pressures are possible on request.

Remarque : des pressions supérieures sont possibles sur demande.

Nota: Pressioni superiori possibili su richiesta.

Code K

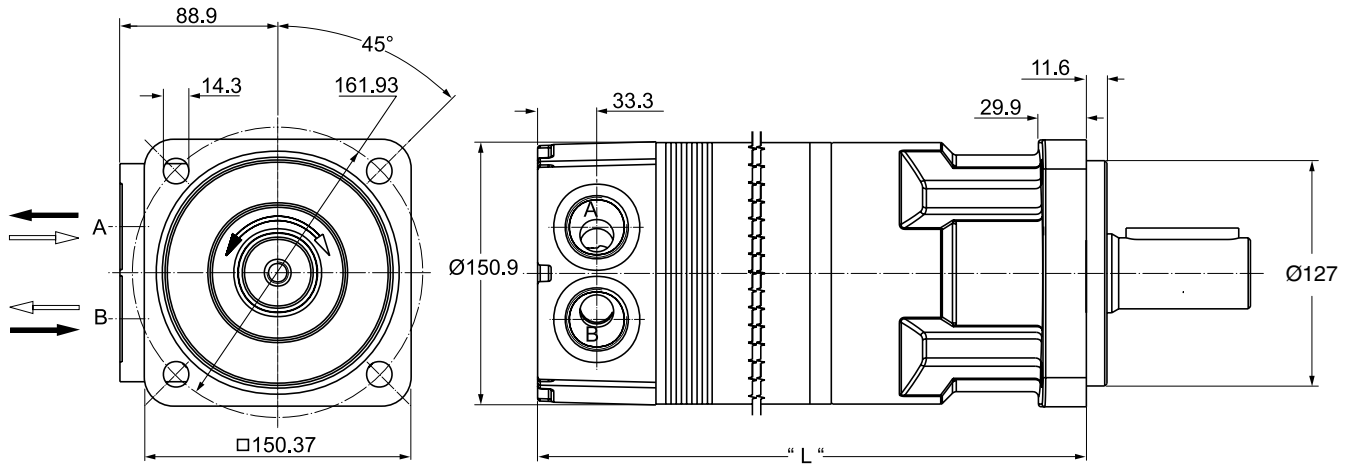

Code R

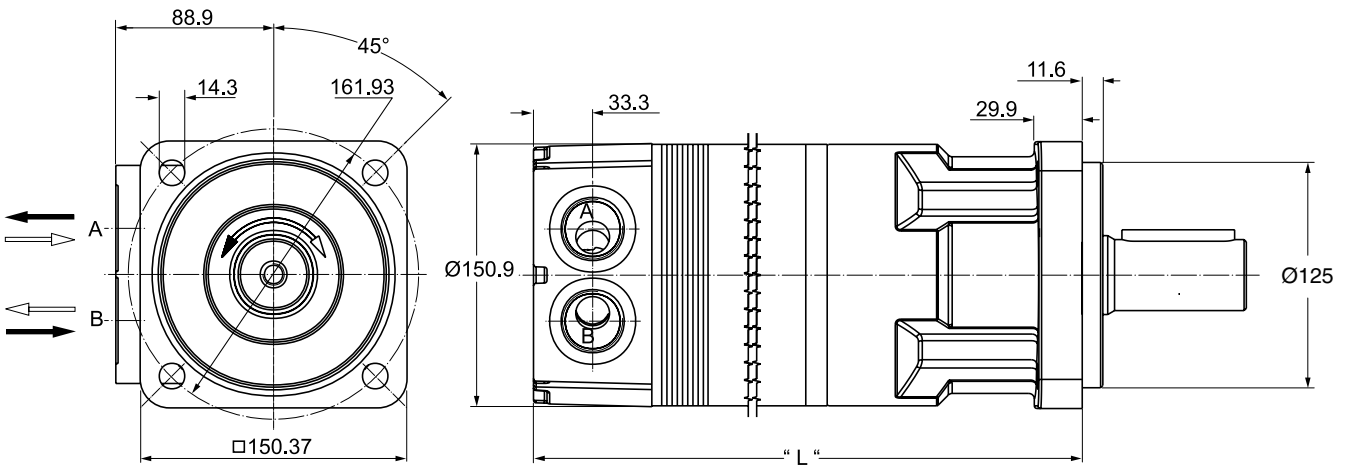

Code T

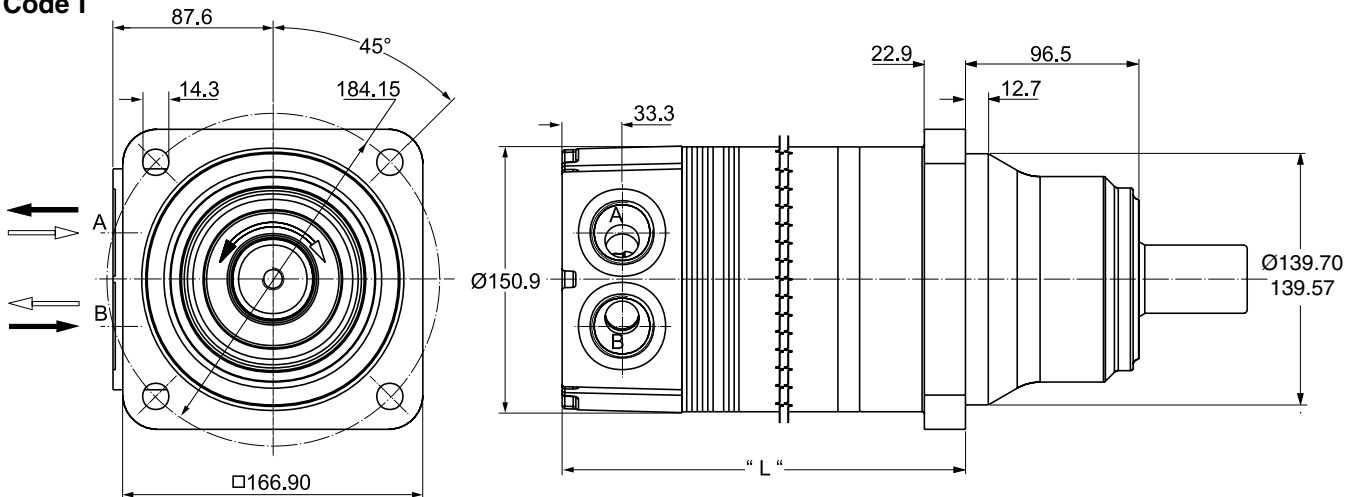

Gewicht / Weight / Poids / Peso	TK250	TK315	TK400	TK500	TK630	TK800	TK1000
Code K, R Code T	32.0	32.7	33.5	34.5	35.7	37.2	39.1
[kg]							
Code K, R Code T	277	282	290	297	310	323	340
"L" [mm]							
Code K, R Code T	191	196	203	213	224	239	257

Code 4

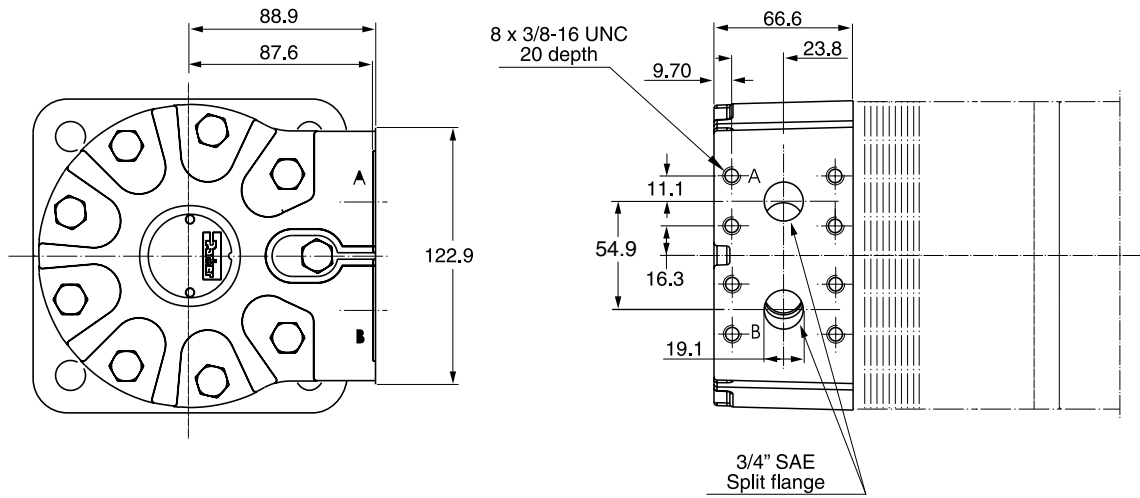

Code 5

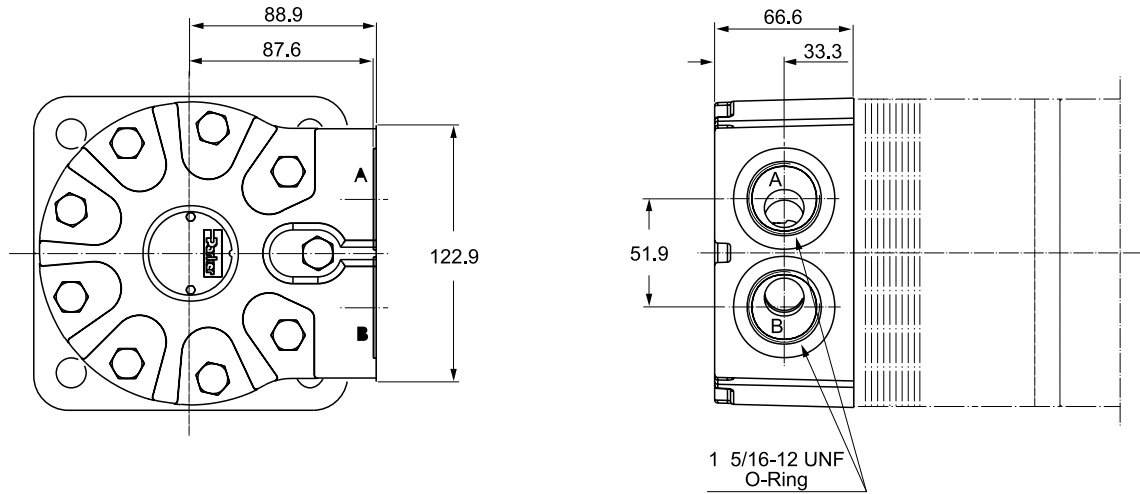

Code 6

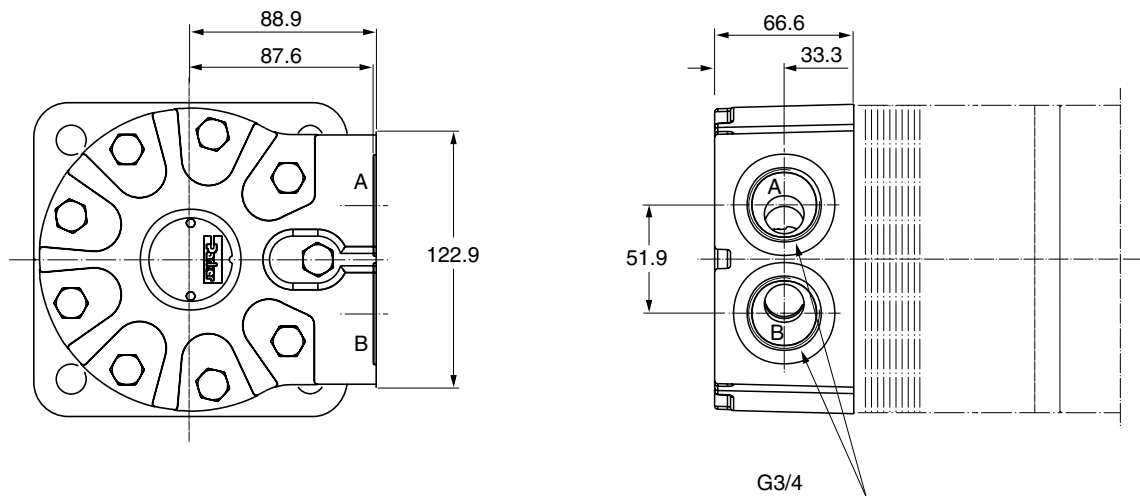

Code 64

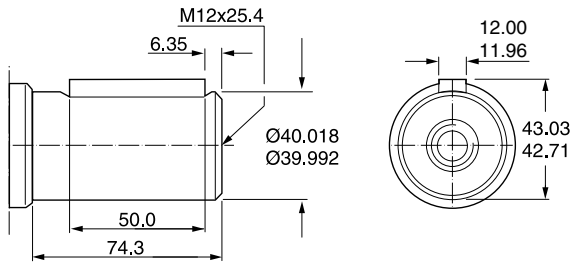

Code 32

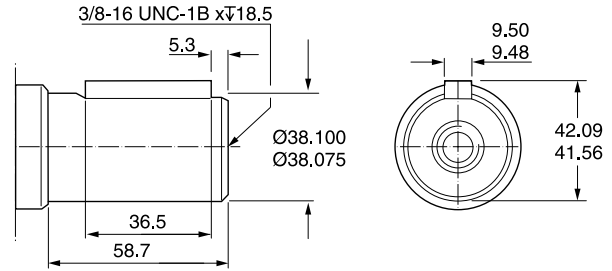

Code 36

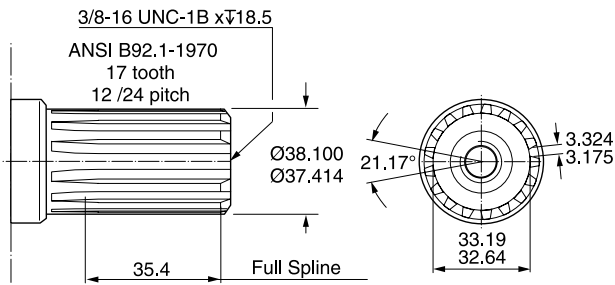

Code 63

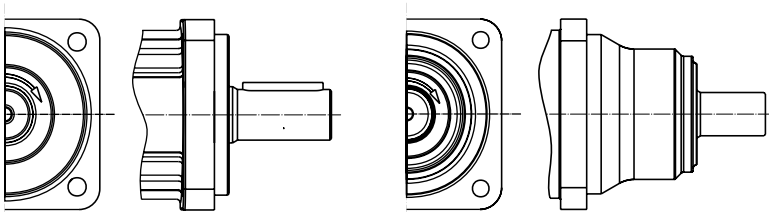
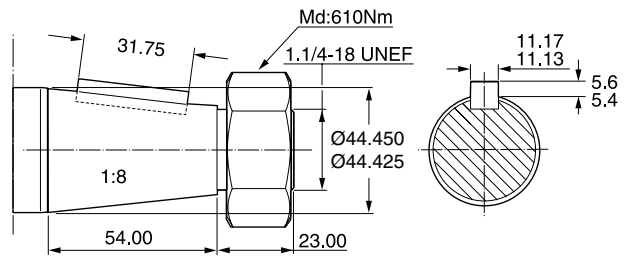

Code 64

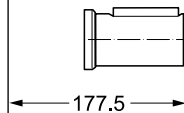
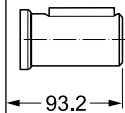

Code 32

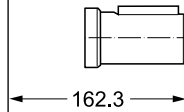
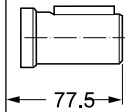

Code 36

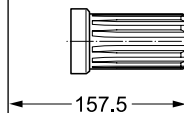
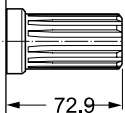

Code 63

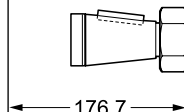
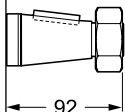

TK 250

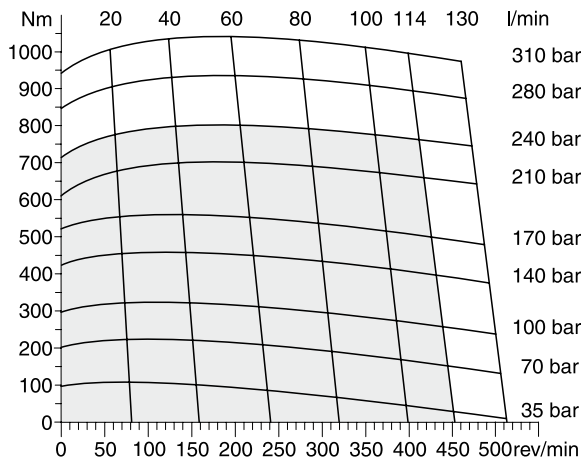

TK 315

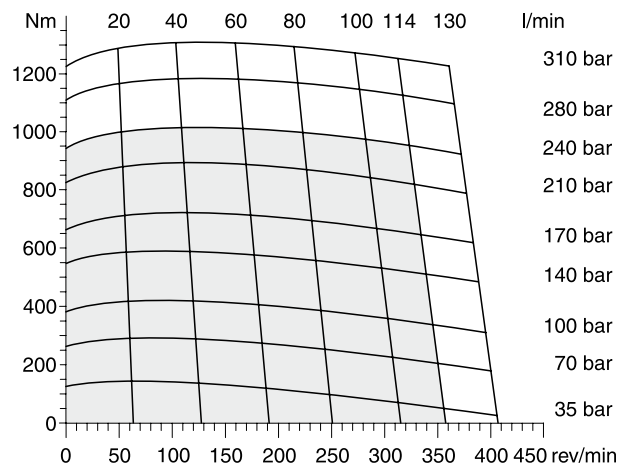

TK 400

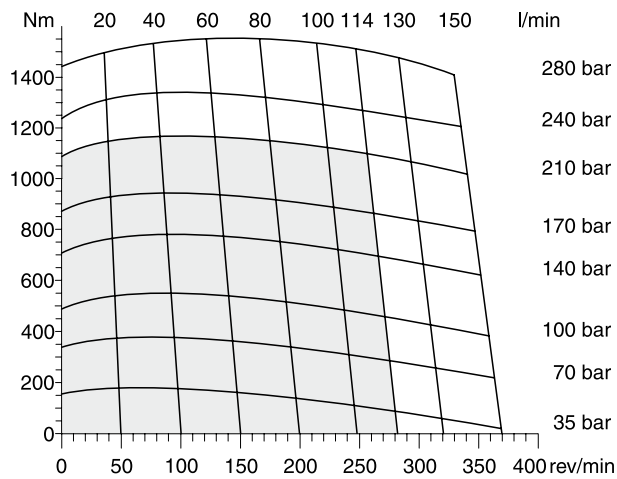

TK 500

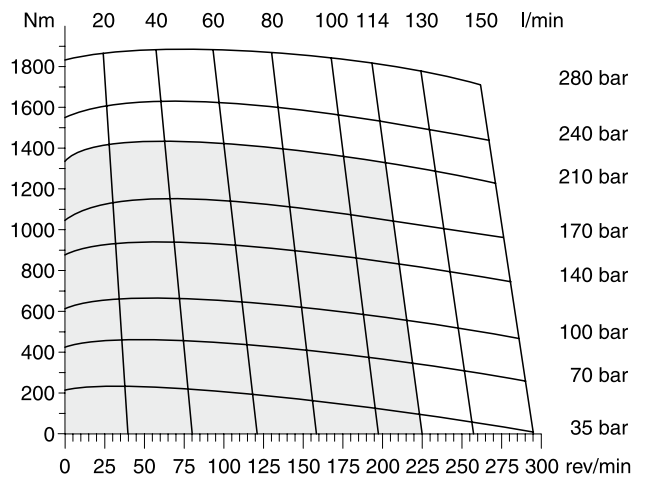

TK 630

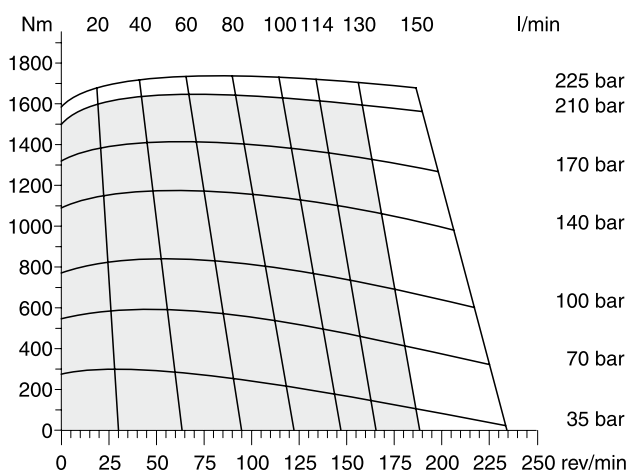

TK 800

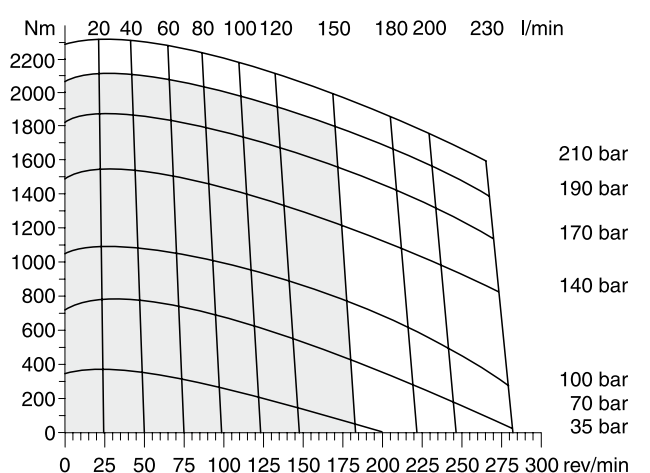

□ Cont. □ Int.

int. =
Intermittierende Werte maximal: 10% von jeder Betriebsminute.
Intermittent operation rating applies to 10% of every minute.
Fonctionnement interm.: 10% max. de chaque minute d' utilisation.
Servizio intermittente: 10% max di ogni minuto di utilizzazione.

TK 1000

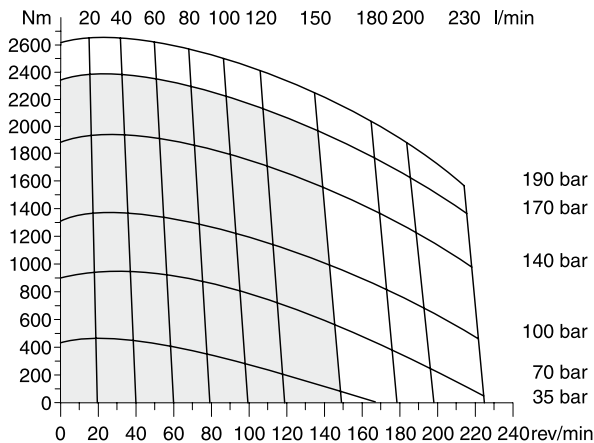

Life Time

Die Lebensdauer der Radiallager (L_h in Stunden) lässt sich nach folgender Formel berechnen. Die Größe F_R ist durch die mechanische Festigkeit der Abtriebswelle begrenzt (siehe Diagramm). Das Maß "L" ist das Längenmaß vom Gehäuseflansch bis zum Angriffspunkt der Radialkraft F_R .

La durée de vie des roulements radiaux (L_h en heures) peut être calculée par les formules suivantes. La grandeur F_R est limitée par les résistances mécaniques de l'arbre de sortie (voir diagramme). La cote "L" est la longueur entre la bride du carter jusqu'au point d'appui de l'effort radial F_R .

Life time (L_h in hours) of the radial bearings can be calculated with the following formula. The value F_R is limited by the mechanical strength of the shaft (see diagram). The measurement "L" is the length from the housing flange up to the point of impact of the radial force F_R .

La durata dei cuscinetti (L_h in ore) può essere calcolata con la seguente formula. Il valore F_R è limitato dalla resistenza meccanica dell'albero (vedi diagramma). La quota "L" è la distanza tra la flangia del corpo ed il punto di applicazione della forza radiale F_R .

Code K

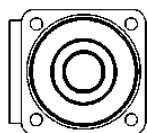

$$L_h = \frac{12 \cdot 10^6}{60 \cdot n} \left\{ \frac{F_a}{F_b} \right\}^{3.33}$$

F_{Radial} [N]

Code T

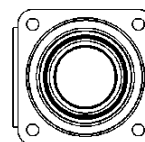

$$L_h = \frac{12 \cdot 10^6}{60 \cdot n} \left\{ \frac{F_a}{F_b} \right\}^{3.33}$$

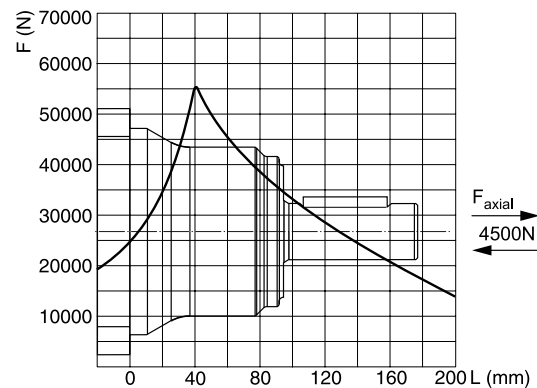
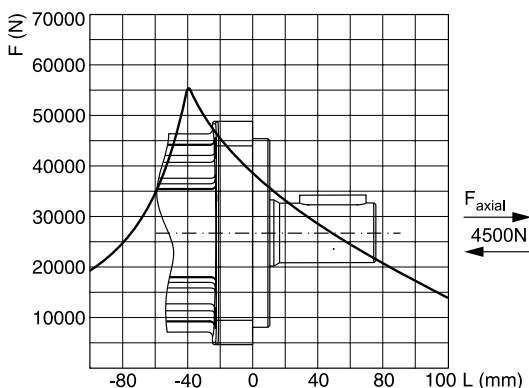

Life in hours / Lebensdauer in Stunden
 Shaft speed / Abtriebswellendrehzahl
 Allowable side load defined by above curve at a distance from mounting flange /
 Erlaubte radiale Wellenbelastung als Funktion der Länge
 Application side load / Anwendungsseitige Wellenbelastung

L_h = [h]
 n = [rev/min]
 F_b = F [N]

Vorstehende Formeln gelten für eine B10-Lebensdauer. / The preceding formulas are valid for a B10 duration of life.
 Les formules précédentes sont valables pour une durée de vie B10. / Le formule precedenti sono valide per una durata della vita B10.

Ordering Code

TK

Serie
Series
Série
Serie

□ □ □ □ □

Schluckvolumen
Displacement
Cylindrée
Cilindrata

□

Gehäuse
Housing
Carter
Corpo motore

□

Anschluss
Ports
Plan de raccorde-
ment
Conessioni

□ □

Welle
Shaft
Arbre
Albero

□



Drehrichtung
Direction of rotation
Direction de rotation
Direzione di rotazione

A A A B

Option

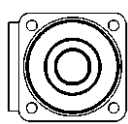
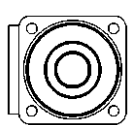
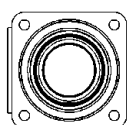
Code	cm ³ /rev
0250	250
0315	315
0400	400
0500	500
0630	630
0800	800
1000	1000

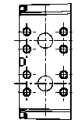
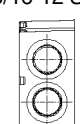
Code	Housing
K	
R ¹⁾	
T	

Code	Port
4	3/4 Split Flange Manifold 
5	1 5/16-12 SAE 
6	G3/4 

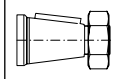
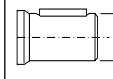
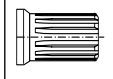
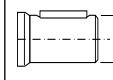
Code	Shaft
63	
32	
36	
64	

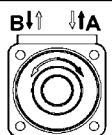
Code	Direction
0	 Standard
1	

Example

Berechnung von Wirkungsgrad und Leistung
Calculation of efficiency and output power
Dètermination du rendement et de la puissance
Calcoli di rendimento e potenza utile

TG 335

Md = 960 Nm
n = 142 rev/min
Δp = 200 bar
V = 337 cm³/rev
Q = 60 l/min

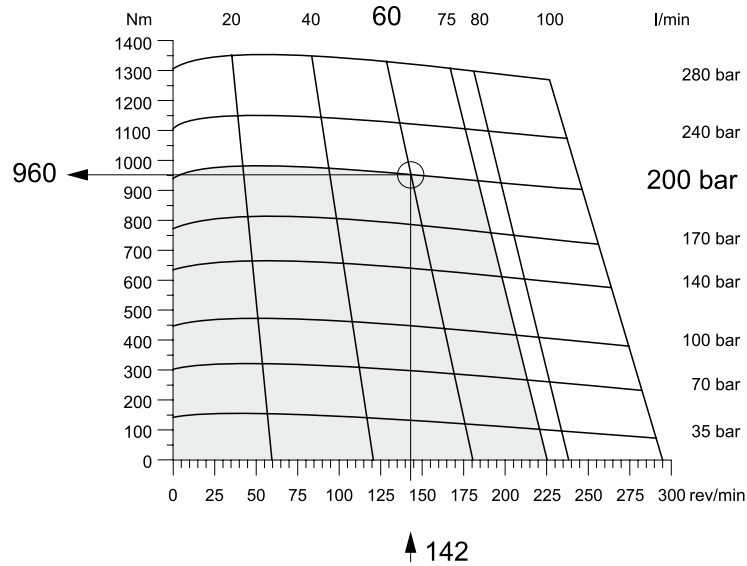

Hydraulisch-mechanischer Wirkungsgrad (η_{hm})
Hydraulic-mechanical efficiency
Rendement hydro-mècanique
Rendimento idro-meccanico

Volumetrischer Wirkungsgrad (η_{vol})
Volumetric efficiency
Rendement volumètrique
Rendimento volumetrico

$$\eta_{hm} = \frac{Md \cdot 20 \cdot \pi}{\Delta p \cdot V} = \frac{960 \cdot 20 \cdot \pi}{200 \cdot 337}$$

$$\eta_{hm} = 0.89$$

$$\eta_{vol} = \frac{n \cdot V}{Q \cdot 10^3} = \frac{142 \cdot 337}{60 \cdot 10^3}$$

$$\eta_{vol} = 0.80$$

Gesamtwirkungsgrad (η_{ges})
Overall efficiency
Rendement global
Rendimento totale

Leistung P (kW)
Power P
Puissance P
Potenza P

$$\eta_{ges} = \eta_{vol} \cdot \eta_{hm} = 0.80 \cdot 0.89$$

$$\eta_{ges} = 0.71$$

$$P = \frac{Md \cdot n \cdot \pi}{10^4 \cdot 3} = \frac{960 \cdot 142 \cdot \pi}{10^4 \cdot 3}$$

$$P = 14.3 \text{ kW}$$

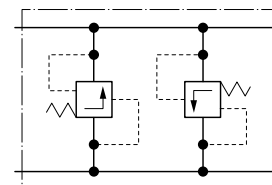
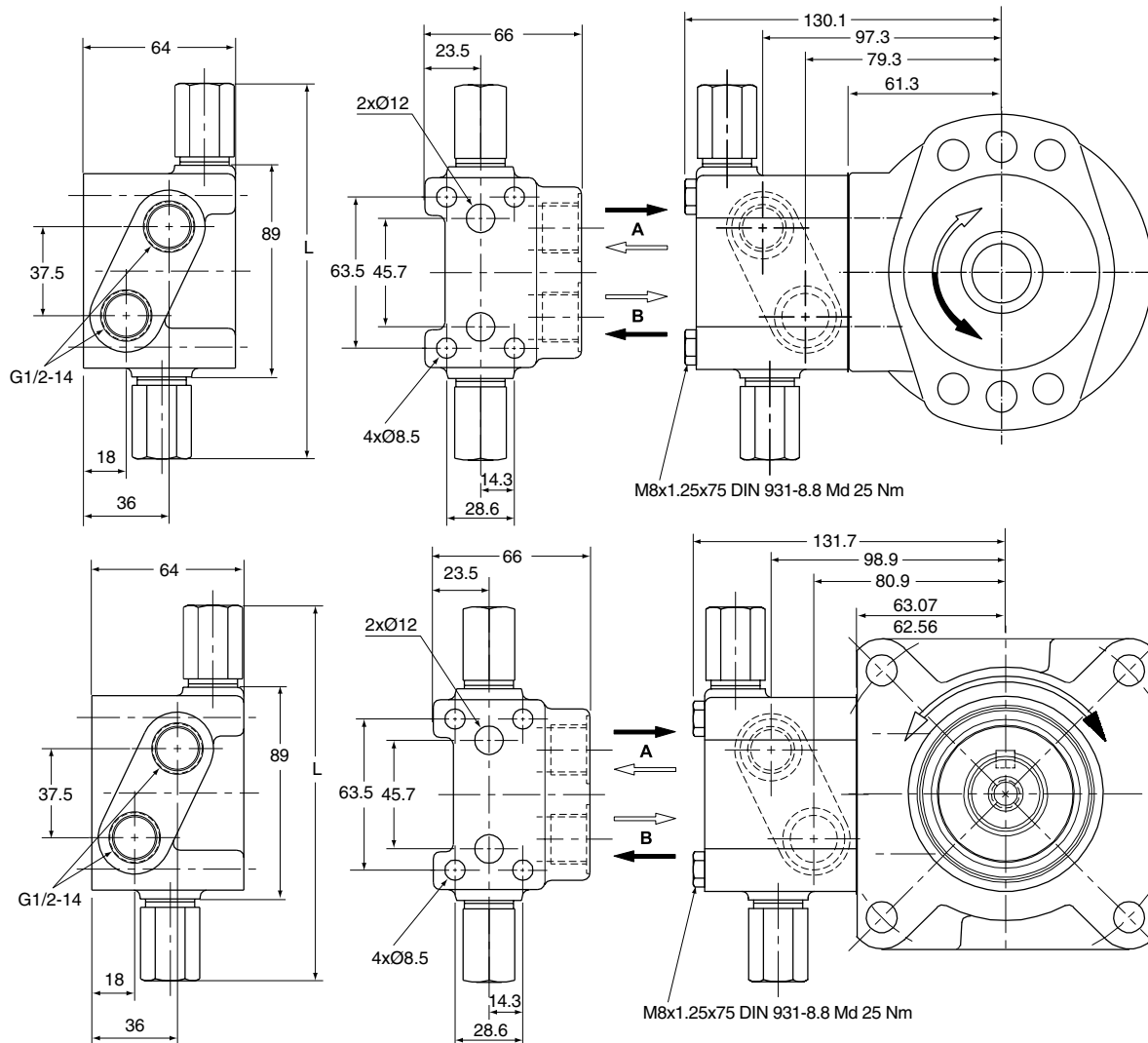

Bestellschlüssel / Ordering Code / Système de commande / Sistema di ordinazione

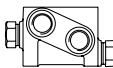
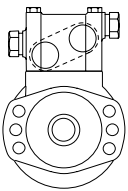
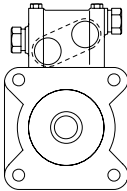
Opening pressure	Single valve 		 (M8)	 (M6)	Length "L"
	Order no. (M8)	Order no. (M6)	Option code	Option code	
100 bar	410017-100	410018-100	HAAP	HAAF	158 mm
140 bar	410017-140	410018-140	HAAU	HAAH	158 mm
170 bar	410017-170	410018-170	HAAX	HAAK	158 mm
200 bar	410017-200	410018-200	HABA	HAAM	158 mm

Zubehör / Fixtures / Fournitures / Part. di fissaggio

4 x M8 (M6) x 75mm ; 2 x O-Ring

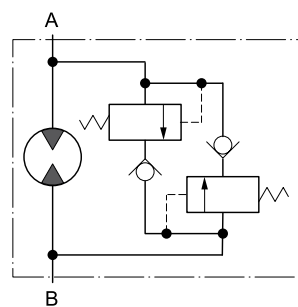
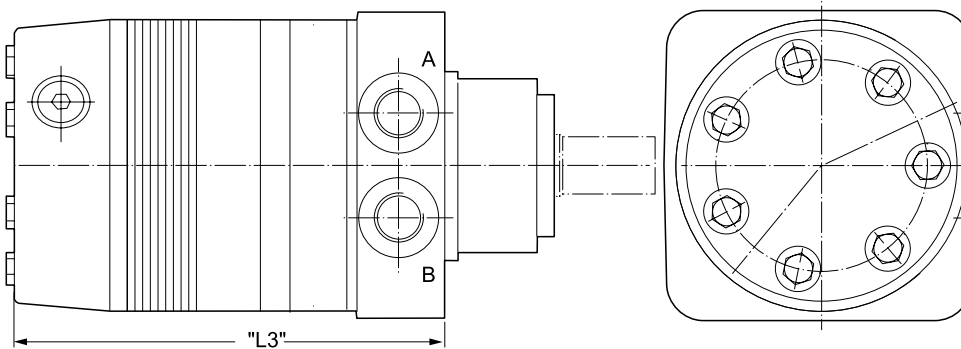
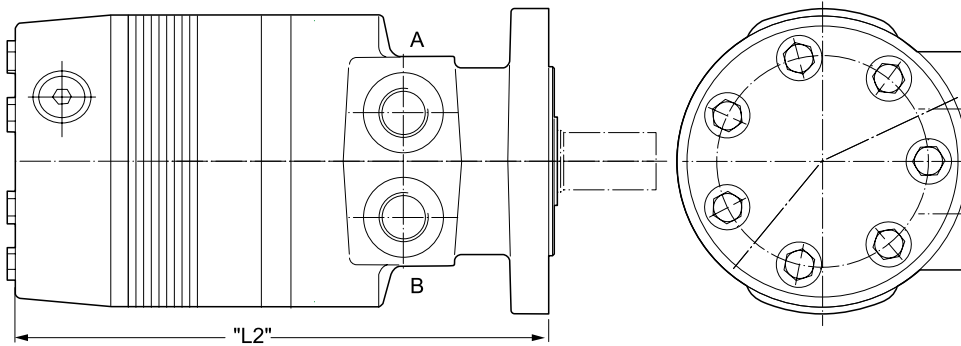
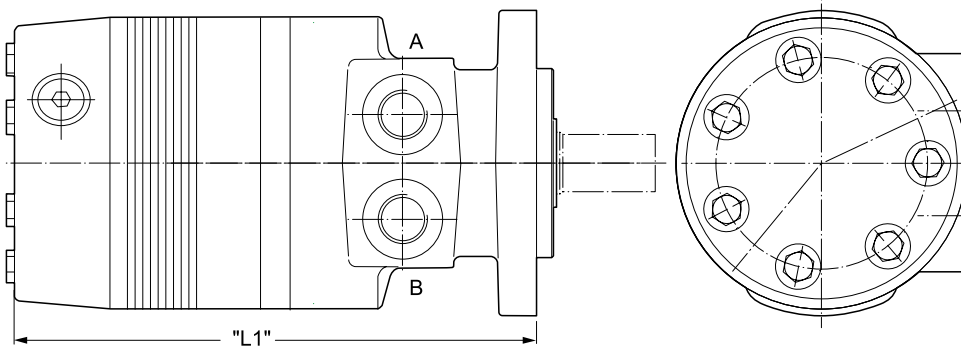

Ventilcurve auf Anfrage
 Valve curve available on request
 La courbe caractéristique de la vanne est disponible sur demande
 Curva della valvola disponibile su richiesta

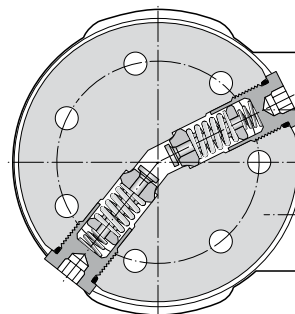

Motor Series	"L1" mm	"L2" mm	"L3" mm
TF80	213.5	218.5	173.2
TF100	213.5	218.5	173.2
TF130	216.5	221.5	176.3
TF140	218.3	223.3	178.1
TG140	218.3	223.3	178.1
TH140		243.6	201.2
TF170	221.3	226.3	181.1
TG170	221.6	226.6	180.4
TH170		246.9	204.3
TF195	224.6	229.6	184.4
TG195	224.6	229.6	184.4
TH195		250.0	207.6
TF240	229.2	234.2	189.0
TG240	229.2	234.2	189.0
TH240		254.8	212.2
TF280	234.0	239.0	193.8
TG280	234.0	239.0	193.8
TH280		259.6	217.0
TG330	240.4	245.4	200.2
TH330		266.0	223.3
TF365	243.7	248.7	203.5
TF405	247.7	252.7	207.5
TG405	247.7	252.7	207.5
TH405		275.3	230.7
TF475	256.4	261.4	216.2
TG475	256.4	261.4	216.2
TH475		281.7	239.3
TG530	262.7	267.7	222.5
TH530		288.1	245.7
TG620	272.1	277.1	231.9
TH620		297.8	255.1
TG790	291.2	296.2	251.0
TH790		316.8	274.1
TG960	310.2	315.2	270.0
TH960		335.9	293.2

Bestellschlüssel / Ordering Code / Système de commande / Sistema di ordinazione

Option code	Opening pressure
BBBM	70 bar
BBBJ	100 bar
BBBN	140 bar
BBCG	170 bar
BBBF	200 bar

Code AAFX

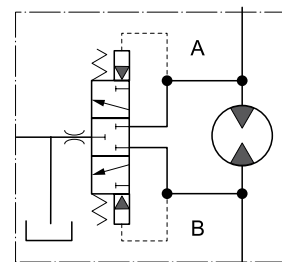
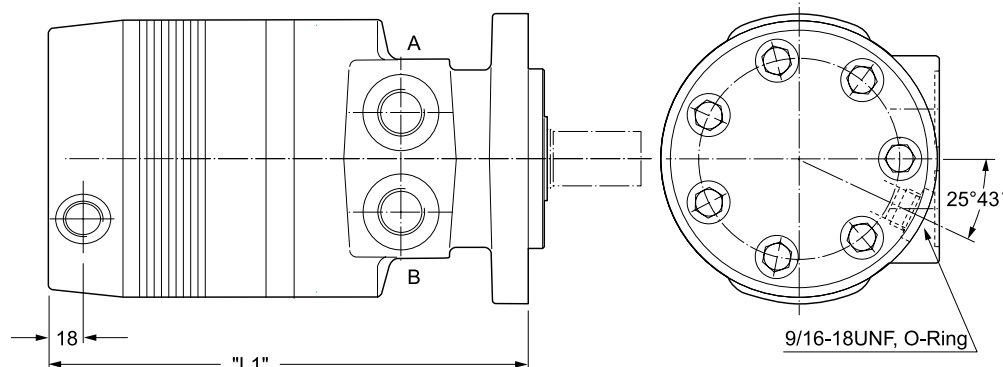

Q=3.5 l p=8 bar \dot{v} =39 mm²/s

Spülventil für geschlossene Systeme zur Rückführung einer definierten Menge des Niederdrucköls in den Tank zur Abkühlung innerhalb desselben Kreislaufs.

Hot oil shuttle valve allows for diverting of low pressure oil in closed loop applications to be returned to tank, cooler or filter for cooling in the same circuit.

Valve de rincage pour systèmes fermés pour le retour d'un volume déterminé de fluide basse pression vers le réservoir, un refroidisseur ou un filtre de réfrigération, dans le même circuit.

Una valvola selettice permette di deviare olio a bassa pressione direttamente al serbatoio o allo scambiatore di calore consentendo, nelle applicazioni a circuito chiuso, un miglior raffreddamento dell'olio.

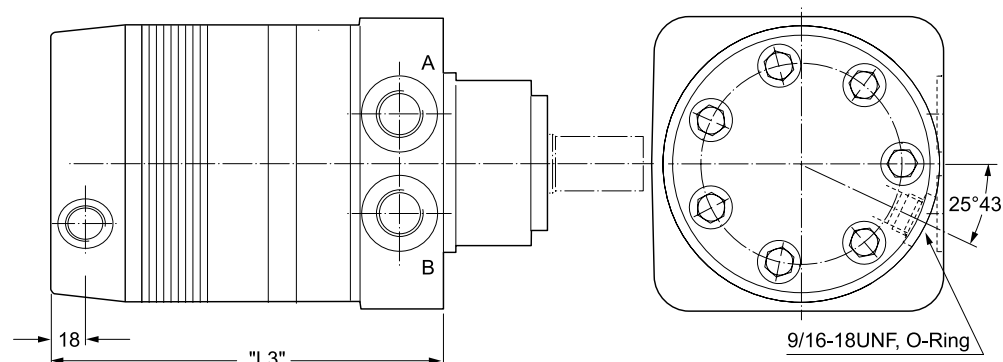
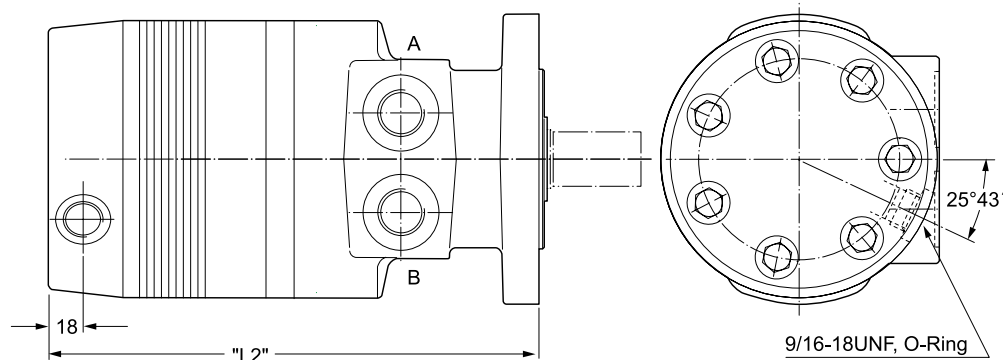

Gewicht / Weight Poids / Peso [kg]		TG140	TG170	TG195	TG240	TG280	TG335	TG405	TG475	TG530	TG625	TG785	TG960
Code AAFX "L1" [mm]		210.5	213.8	216.8	221.4	226.2	232.6	239.9	248.6	254.9	264.3	283.4	302.4
Code AAFX "L2" [mm]		215.5	218.8	221.8	226.4	231.2	237.6	244.9	253.6	259.9	269.3	288.4	307.4
Code AAFX "L3" [mm]		170.3	173.6	176.6	181.2	186.0	192.4	199.7	208.4	214.7	224.1	243.2	262.2

Gewicht / Weight Poids / Peso [kg]		TF80	TF100	TF130	TF140	TF170	TF195	TF240	TF280	TF360	TF405	TF475
Code AAFX "L1" [mm]		205.9	205.9	208.9	210.9	213.9	216.9	221.9	225.9	234.9	239.9	248.9
Code AAFX "L2" [mm]		210.9	210.9	213.9	215.9	218.9	221.9	226.9	231.9	239.9	244.9	253.9
Code AAFX "L3" [mm]		165.9	165.9	168.9	170.9	173.9	176.9	181.9	186.9	194.9	199.9	208.9

Code AAFX

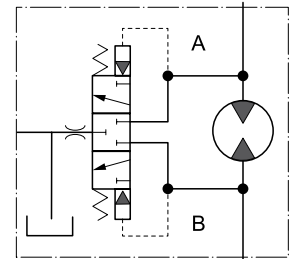
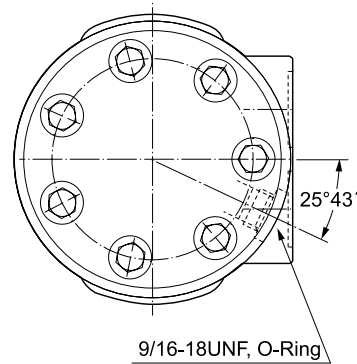
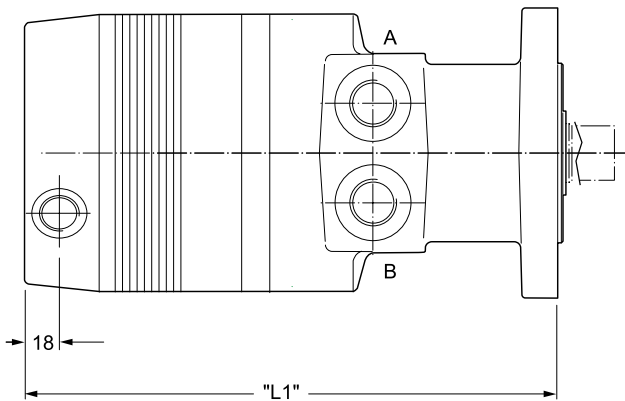

Q=4.35l p=8bar \dot{v} =39mm²/s

Spülventil für geschlossene Systeme zur Rückführung einer definierten Menge des Niederdrucköls in den Tank zur Abkühlung innerhalb desselben Kreislaufs.

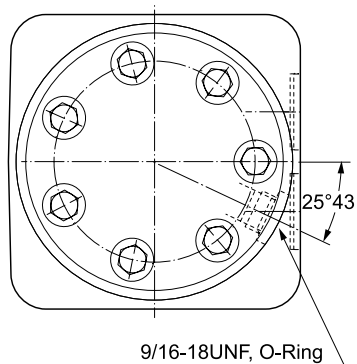
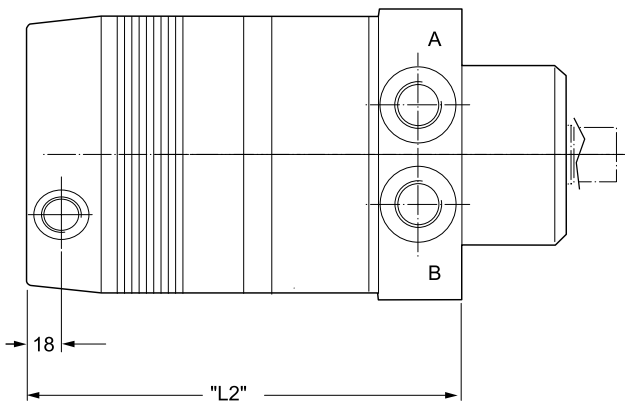

Hot oil shuttle valve allows for diverting of low pressure oil in closed loop applications to be re-turned to tank, cooler or filter for cooling in the same circuit.

Valve de rincage pour systèmes fermés pour le retour d'un volume déterminé de fluide basse pression vers le réservoir, un refroidisseur ou un filtre de réfrigération, dans le même circuit.

Una valvola selettice permette di deviare olio a bassa pressione direttamente al serbatoio o allo scambiatore di calore consentendo, nelle applicazioni a circuito chiuso, un miglior raffreddamento dell'olio.

Gewicht / Poids / Peso [kg]	Weight Peso [kg]	TH140	TH170	TH195	TH240	TH280	TH335	TH405	TH475	TH530	TH620	TH785	TH960
Code AAFX	"L1" [mm]	235.8	239.1	242.2	247.0	251.8	258.2	265.5	273.9	280.3	290.0	309.0	328.1
Code AAFX	"L2" [mm]	193.4	196.5	200.0	204.4	209.2	215.5	222.9	231.5	237.9	247.3	266.3	285.4

Speed Sensor

Torqmotor Series TE-TJ / TF / TG

Dieser robuste, wetterfeste Drehzahlaufnehmer arbeitet nach dem Halleffekt. Es werden 30 Rechteckimpulse pro Abtriebswellenumdrehung erzeugt. Durch Erfassung der positiven und negativen Wellenflanken sind 60 Impulse pro Umdrehung möglich. Der Sensor führt zu keiner Leistungsbeschränkung des Motors. Die volle Radiallastkapazität bleibt erhalten.

This rugged, weather resistant speed sensor is a Hall effect device. When externally powered, 30 square wave digital pulses per output shaft revolution are produced. By signal multiplication, 60 pulses per revolution can be obtained. The installation of this economical sensor does not affect the torque or side load capability of the motor into which it is installed.

Un capteur économique pour mesure de la vitesse. Ce capteur robuste et résistant aux intempéries est a effet Hall. Alimenté par une source externe, il fournit 30 impulsions carrées par tour. Par multiplication électronique, on obtient 60 impulsions par tour. Son montage ne modifie pas le couple ni la charge radiale du moteur qui le reçoit.

Sensore di velocità ad effetto Hall, estremamente robusto e resistente alle condizioni ambientali. Genera 30 impulsi al giro, con uscita digitale ad onda quadra. Il numero di impulsi può essere elettronicamente raddoppiato. L'utilizzo di questo sensore, non influisce sulle caratteristiche di coppia o di potenza del motore idraulico.

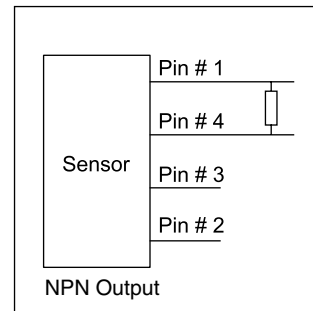
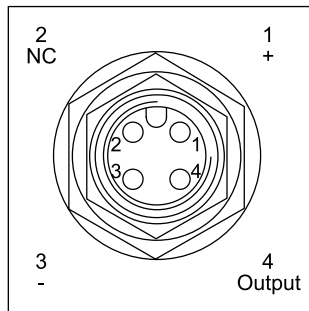

Versorgungsspannung Operating voltage range Courant d'alimentation Tensione di alimentazione	4.5...24 V (DC)
Arbeitstemperatur Operating temperature Température Temperatura di funzionamento	-30°...100° C
Arbeitsfrequenz Operating frequency range Fréquence d'utilisation Frequenza di lavoro	0...10 KHZ
Erforderlicher Laststrom Sink current Courant depeau Corrente di alimentazione	0...20 mA (max.)
Anschluss Connection Raccordement Connessione elettrica	4 Pin (12mm) DIN Standard

Formel Pullup-Widerstand Formula pull-up resistor value Formule valeur pull-up resistor Calcolo resistenza di carico	(0.25 Watt, Tol. 5%) (0.25 Watt, 5% tol.) (0.25 Watt, tol. 5%) (0.25 Watt, toll. 5%)	Spannung/Voltage Courant/Tensione	4.5...24 V	=	Widerstand Resistor k Ohm
		Laststrom/Sink current Courant/Corrente	0...20 mA		Résistance Resistenze
		Status: aus/State: off Courant: off/Condizione: off (95% +V)			
		+ V			Status: ein/State: on Courant: on/Condizione: on (max. 0.4 V DC)
		0 V			

Option FSAB

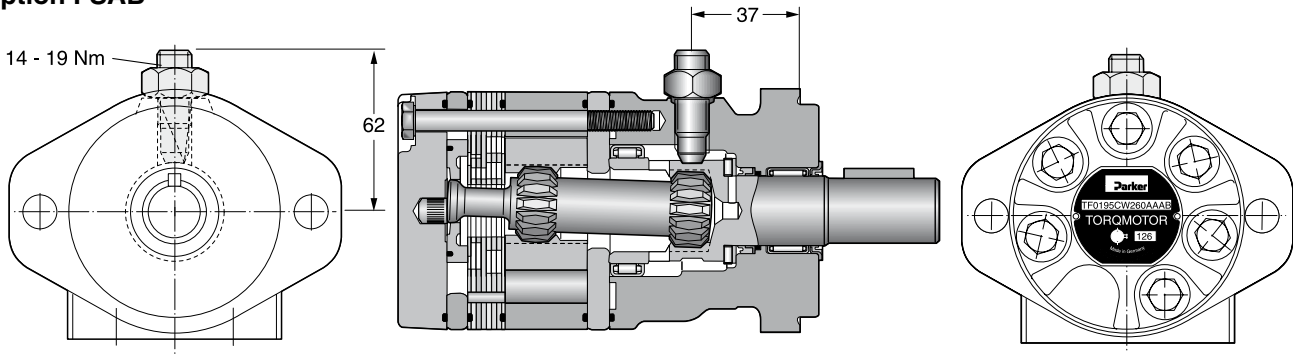

Der Sensor ist gegen Verpolung der Versorgungsspannung, jedoch nicht gegen Kurzschluss geschützt.

Le capteur est protégé contre l'inversion de polarité de la tension d'alimentation, mais pas contre les courts circuits.

The sensor has reverse polarity protection but no short circuit protection.

Il sensore è protetto contro l'inversione della polarità della tensione di alimentazione, ma non contro il corto circuito.

Ordering code

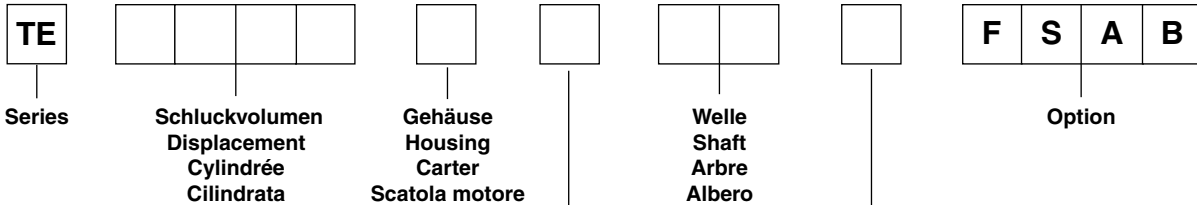

Anschluss Ports Plan de raccordement Conessioni		Drehrichtung Direction of rotation Direction de rotation Direzione di rotazione	
Code	cm ³ /rev	Code	Direction
0036	36	0	B ↓ ↑ A Standard
0045	41	1	B ↓ ↑ A
0050	50		
0065	66		
0080	82		
0100	98		
0130	130		
0165	163		
0195	196		
0230	228		
0260	261		
0295	293		
0330	326		
0365	370		
0390	392		

Housing		Port		Shaft	
Code	Housing	Code	Port	Code	Shaft
C		W	G 1/2	26	
		N	universal port M8x13	10	
		Y	rear port G 1/2 axial	41	
					6B SAE

Option: FSAB

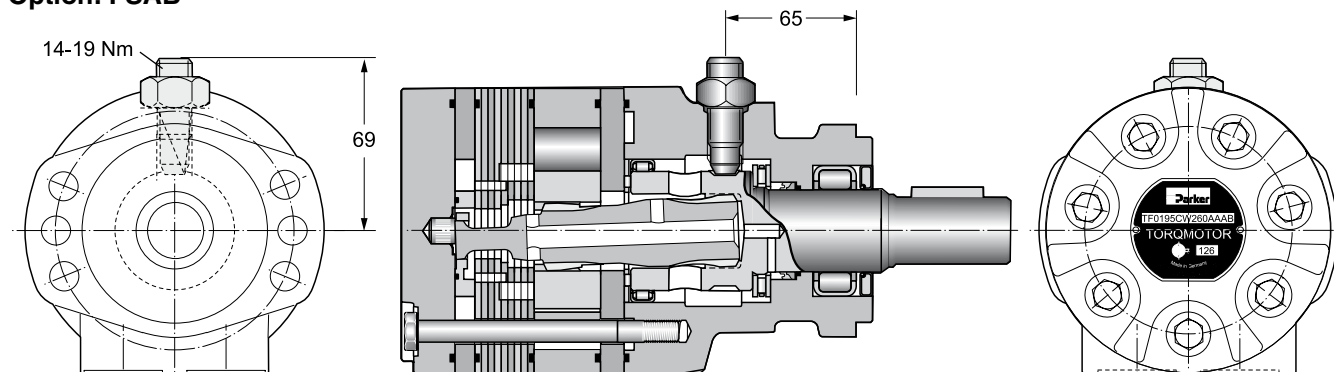

Der Sensor ist gegen Verpolung der Versorgungsspannung, jedoch nicht gegen Kurzschluss geschützt.

Le capteur est protégé contre l'inversion de polarité la tension d'alimentation, mais pas contre les courts-circuits.

The sensor has reverse polarity protection but no short circuit protection.

Il sensore é protetto contro l'inversione della polarità della tensione di alimentazione, ma non contro corto circuito.

Ordering Code

Code	Schluckvolumen Displacement Cylindrée Cilindrata	Gehäuse Housing Carter Corpo motore	Anschluss Ports Plan de raccordement Conessioni	Welle Shaft Arbre Albero	Drehrichtung Direction of rotation Direction de rotation Direzione di rotazione	Option																																																																																																		
<table border="1" style="width: 100%; border-collapse: collapse;"> <tr><td style="text-align: center;">Code</td></tr> <tr><td style="text-align: center;">TF</td></tr> <tr><td style="text-align: center;">TG</td></tr> </table>	Code	TF	TG	<table border="1" style="width: 100%; border-collapse: collapse;"> <tr><td style="text-align: center;">Code</td><td style="text-align: center;">cm³/rev</td></tr> <tr><td style="text-align: center;">0080</td><td style="text-align: center;">81</td></tr> <tr><td style="text-align: center;">0100</td><td style="text-align: center;">100</td></tr> <tr><td style="text-align: center;">0130</td><td style="text-align: center;">128</td></tr> <tr><td style="text-align: center;">0140</td><td style="text-align: center;">141</td></tr> <tr><td style="text-align: center;">0170</td><td style="text-align: center;">169</td></tr> <tr><td style="text-align: center;">0195</td><td style="text-align: center;">195</td></tr> <tr><td style="text-align: center;">0240</td><td style="text-align: center;">237</td></tr> <tr><td style="text-align: center;">0280</td><td style="text-align: center;">280</td></tr> <tr><td style="text-align: center;">0360</td><td style="text-align: center;">364</td></tr> <tr><td style="text-align: center;">0405</td><td style="text-align: center;">405</td></tr> <tr><td style="text-align: center;">0475</td><td style="text-align: center;">477</td></tr> <tr><td style="text-align: center;">Code</td><td style="text-align: center;">cm³/rev</td></tr> <tr><td style="text-align: center;">0140</td><td style="text-align: center;">140</td></tr> <tr><td style="text-align: center;">0170</td><td style="text-align: center;">169</td></tr> <tr><td style="text-align: center;">0195</td><td style="text-align: center;">195</td></tr> <tr><td style="text-align: center;">0240</td><td style="text-align: center;">237</td></tr> <tr><td style="text-align: center;">0280</td><td style="text-align: center;">280</td></tr> <tr><td style="text-align: center;">0335</td><td style="text-align: center;">337</td></tr> <tr><td style="text-align: center;">0405</td><td style="text-align: center;">405</td></tr> <tr><td style="text-align: center;">0475</td><td style="text-align: center;">476</td></tr> <tr><td style="text-align: center;">0530</td><td style="text-align: center;">529</td></tr> <tr><td style="text-align: center;">0625</td><td style="text-align: center;">624</td></tr> <tr><td style="text-align: center;">0785</td><td style="text-align: center;">786</td></tr> <tr><td style="text-align: center;">0960</td><td style="text-align: center;">958</td></tr> </table>	Code	cm ³ /rev	0080	81	0100	100	0130	128	0140	141	0170	169	0195	195	0240	237	0280	280	0360	364	0405	405	0475	477	Code	cm ³ /rev	0140	140	0170	169	0195	195	0240	237	0280	280	0335	337	0405	405	0475	476	0530	529	0625	624	0785	786	0960	958	<table border="1" style="width: 100%; border-collapse: collapse;"> <tr><td style="text-align: center;">Code</td><td style="text-align: center;">Housing</td></tr> <tr><td style="text-align: center;">E</td><td style="text-align: center;"></td></tr> <tr><td style="text-align: center;">Code</td><td style="text-align: center;">Port</td></tr> <tr><td style="text-align: center;">W</td><td style="text-align: center;">G 1/2</td></tr> </table>	Code	Housing	E		Code	Port	W	G 1/2	<table border="1" style="width: 100%; border-collapse: collapse;"> <tr><td style="text-align: center;">Code</td><td style="text-align: center;">Shaft</td></tr> <tr><td style="text-align: center;">26¹⁾</td><td style="text-align: center;"></td></tr> <tr><td style="text-align: center;">08</td><td style="text-align: center;"></td></tr> <tr><td style="text-align: center;">46</td><td style="text-align: center;"></td></tr> </table> <p><small>1) Nur für TF Motoren Only possible for TF motors Possible seulement avec TF moteur Possible solo con motore TF</small></p>	Code	Shaft	26 ¹⁾		08		46		<table border="1" style="width: 100%; border-collapse: collapse;"> <tr><td style="text-align: center;">Code</td><td style="text-align: center;">Direction</td></tr> <tr><td style="text-align: center;">0</td><td style="text-align: center;"> <table border="1" style="width: 100%; border-collapse: collapse;"> <tr><td style="text-align: center;">B</td><td style="text-align: center;">↑↑</td><td style="text-align: center;">↓↓</td><td style="text-align: center;">A</td></tr> <tr><td colspan="4" style="text-align: center;"></td></tr> <tr><td colspan="4" style="text-align: center;">Standard</td></tr> </table> </td></tr> <tr><td style="text-align: center;">1</td><td style="text-align: center;"> <table border="1" style="width: 100%; border-collapse: collapse;"> <tr><td style="text-align: center;">B</td><td style="text-align: center;">↑↑</td><td style="text-align: center;">↓↓</td><td style="text-align: center;">A</td></tr> <tr><td colspan="4" style="text-align: center;"></td></tr> </table> </td></tr> </table>	Code	Direction	0	<table border="1" style="width: 100%; border-collapse: collapse;"> <tr><td style="text-align: center;">B</td><td style="text-align: center;">↑↑</td><td style="text-align: center;">↓↓</td><td style="text-align: center;">A</td></tr> <tr><td colspan="4" style="text-align: center;"></td></tr> <tr><td colspan="4" style="text-align: center;">Standard</td></tr> </table>	B	↑↑	↓↓	A					Standard				1	<table border="1" style="width: 100%; border-collapse: collapse;"> <tr><td style="text-align: center;">B</td><td style="text-align: center;">↑↑</td><td style="text-align: center;">↓↓</td><td style="text-align: center;">A</td></tr> <tr><td colspan="4" style="text-align: center;"></td></tr> </table>	B	↑↑	↓↓	A					<table border="1" style="width: 100%; border-collapse: collapse;"> <tr><td style="text-align: center;">F</td><td style="text-align: center;">S</td><td style="text-align: center;">A</td><td style="text-align: center;">B</td></tr> </table>	F	S	A	B
Code																																																																																																								
TF																																																																																																								
TG																																																																																																								
Code	cm ³ /rev																																																																																																							
0080	81																																																																																																							
0100	100																																																																																																							
0130	128																																																																																																							
0140	141																																																																																																							
0170	169																																																																																																							
0195	195																																																																																																							
0240	237																																																																																																							
0280	280																																																																																																							
0360	364																																																																																																							
0405	405																																																																																																							
0475	477																																																																																																							
Code	cm ³ /rev																																																																																																							
0140	140																																																																																																							
0170	169																																																																																																							
0195	195																																																																																																							
0240	237																																																																																																							
0280	280																																																																																																							
0335	337																																																																																																							
0405	405																																																																																																							
0475	476																																																																																																							
0530	529																																																																																																							
0625	624																																																																																																							
0785	786																																																																																																							
0960	958																																																																																																							
Code	Housing																																																																																																							
E																																																																																																								
Code	Port																																																																																																							
W	G 1/2																																																																																																							
Code	Shaft																																																																																																							
26 ¹⁾																																																																																																								
08																																																																																																								
46																																																																																																								
Code	Direction																																																																																																							
0	<table border="1" style="width: 100%; border-collapse: collapse;"> <tr><td style="text-align: center;">B</td><td style="text-align: center;">↑↑</td><td style="text-align: center;">↓↓</td><td style="text-align: center;">A</td></tr> <tr><td colspan="4" style="text-align: center;"></td></tr> <tr><td colspan="4" style="text-align: center;">Standard</td></tr> </table>	B	↑↑	↓↓	A					Standard																																																																																														
B	↑↑	↓↓	A																																																																																																					
Standard																																																																																																								
1	<table border="1" style="width: 100%; border-collapse: collapse;"> <tr><td style="text-align: center;">B</td><td style="text-align: center;">↑↑</td><td style="text-align: center;">↓↓</td><td style="text-align: center;">A</td></tr> <tr><td colspan="4" style="text-align: center;"></td></tr> </table>	B	↑↑	↓↓	A																																																																																																			
B	↑↑	↓↓	A																																																																																																					
F	S	A	B																																																																																																					

Kenndaten / Performance / Puissance / Potenza

Drehmoment (Nasslauf)/Torque (wet operation)/Couple/Coppia statica	dyn. Ms Nm	1000
Luftüberdruck/Pressure rating/Pression de déblocage/Pressione sbloccaggio	p min. bar	19-21
	p max. bar	210
Drehzahl/Speed/Vitesse de rotation/Velocità di rotazione	n max. U/min	710
	n max. rev/min	
	n max. tr/min	
	n maxi giri/min	
Hubvolumen/Working stroke Cylindrée/Cilindrata	cm ³ max.	22.5

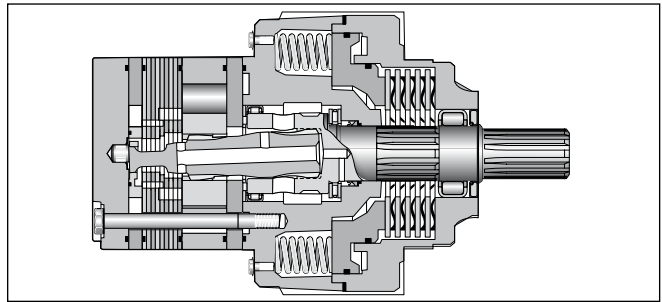

Gewicht / Weight	BG140	BG170	BG195	BG240	BG280	BG335	BG405	BG475	BG530	BG625	BG785	BG960
Poids / Peso kg	27.3	27.5	27.8	28.1	28.5	28.9	29.5	30.2	30.9	31.7	33.2	34.9
Code A+C "L" mm	192.3	195.3	198.6	203.2	208.0	214.4	221.7	230.4	236.7	246.1	265.2	284.2

Shaft Code 05

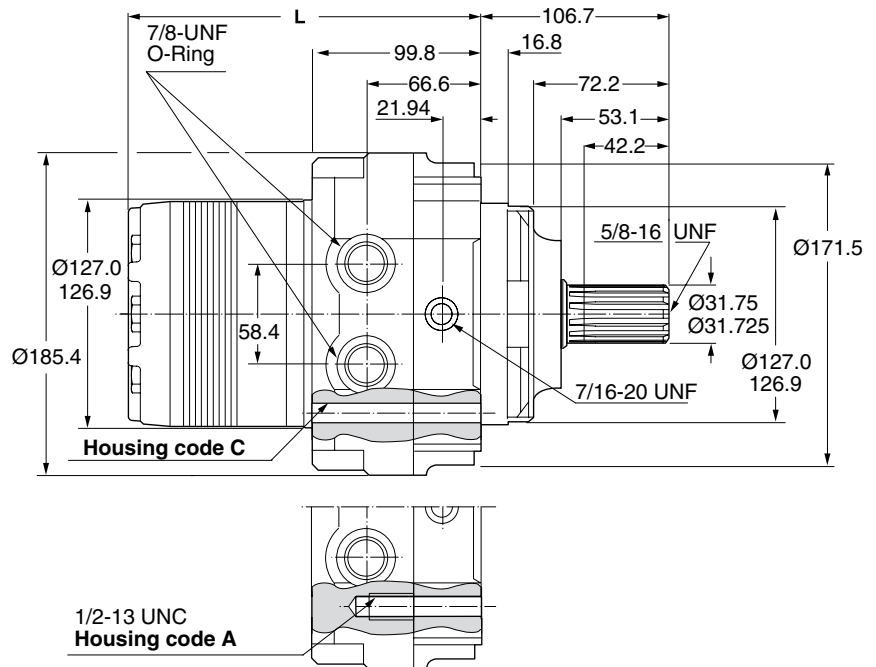
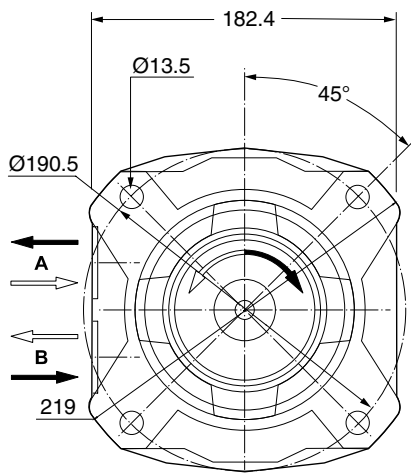

Shaft Code 19

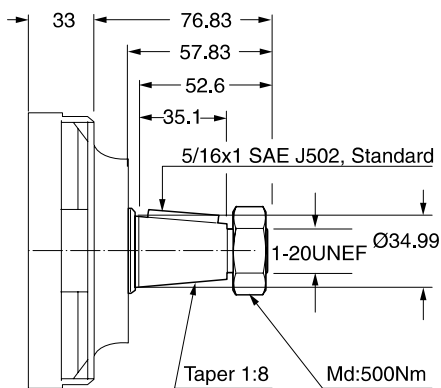

Shaft Code 03

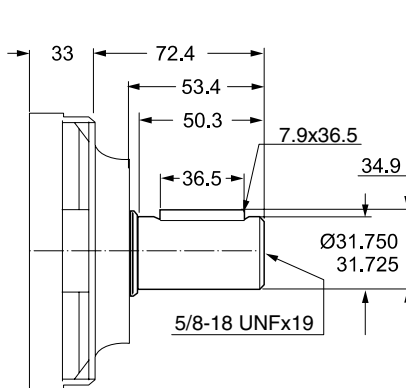

Shaft Code 08

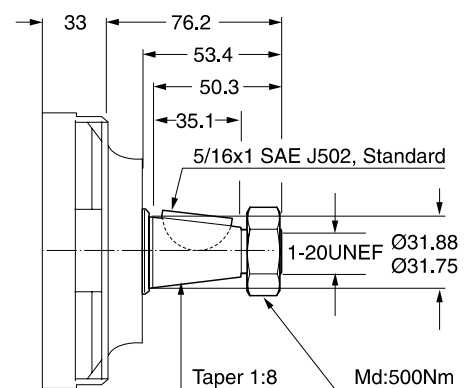

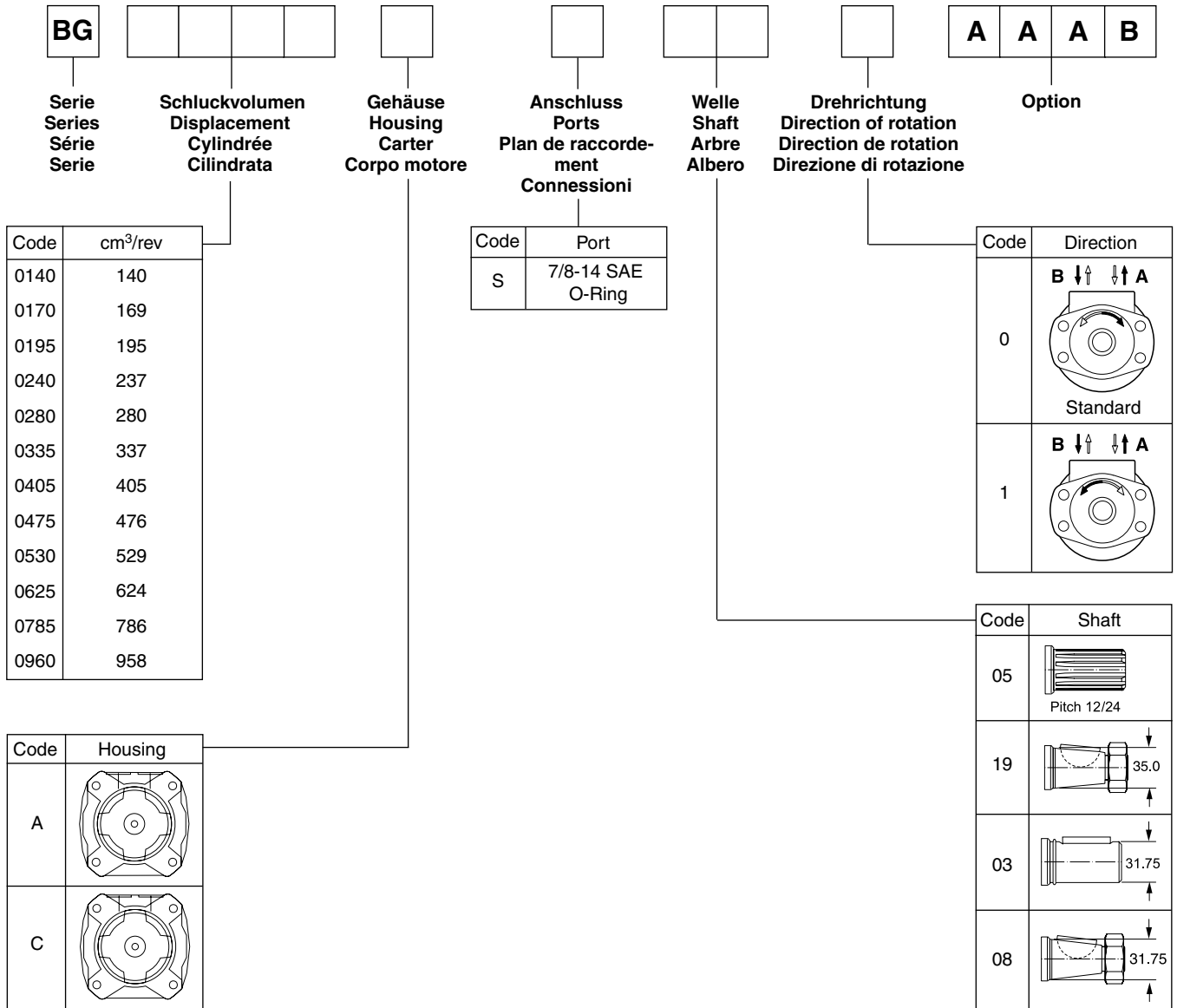

Option Codes

Option Code	Description	Series	TE/TJ	TF	TL	TG	TH	TK
AAAA	black paint		x	x		x	x	x
AAAH	FPM seals		x	x		x	x	x
AABP	castle nut		x	x		x	x	x
AAFX	shuttle valve			x		x	x	
BBBF	internal relief valve 200bar			x		x	x	
BBBJ	internal relief valve 100bar			x		x	x	
BBBM	internal relief valve 70bar			x		x	x	
BBBN	internal relief valve 140bar			x		x	x	
BBCG	internal relief valve 170bar			x		x	x	
HAAF	external relief valve 100bar (M6)			x		x		
HAAP	external relief valve 100bar (M8)		x	x		x	x	
HAAH	external relief valve 140bar (M6)			x		x		
HAAU	external relief valve 140bar (M8)		x	x		x	x	
HAAK	external relief valve 170bar (M6)			x		x		
HAAX	external relief valve 170bar (M8)		x	x		x	x	
HAAM	external relief valve 200bar (M6)			x		x		
HABA	external relief valve 200bar (M8)			x		x	x	
JAAB	motor-brake combination 11bar		x	x				
JAAD	motor-brake combination 16bar		x	x				
JAAG	motor-brake combination 22bar		x	x				
JAAJ	motor-brake combination 11bar			x		x		
JAAL	motor-brake combination 16bar			x		x		
JAAH	motor-brake combination 22bar			x		x		
JAAT	motor-brake combination 22bar			x		x		
JAAW	motor-brake combination 22bar			x		x		
FSAB	Speedsensor		X	x		x		
FSAA	Speedsensor + Lack		x	x		x		
FSBR	Speedsensor Detection of rotating direction		x	x		x		
FSAN	Int Short Speed Sensor, 1500 psi Int Bidirectional Relief, No paint			x		x		

Empfohlen wird die Verwendung eines Hydrauliköls auf Mineralölbasis mit mindestens 0,1% Zinkadditiv als Anti-verschleißzusatz. Vor Einsatz anderer Flüssigkeiten bitten wir um Rücksprache mit unserer Technik.

Die normale Arbeitstemperatur sollte im Bereich von +30 °C bis +60 °C liegen.

Die Maximaltemperatur darf +90 °C nicht überschreiten, während die Mindesttemperatur auf -30 °C begrenzt ist.

Wird die normale Arbeitstemperatur wesentlich überschritten, wird die Lebensdauer des Öls stark verkürzt.

Die Viskosität im Arbeitstemperaturbereich sollte 20 bis 120 mm²/s betragen.

Zweckmäßig ist eine Filtereinheit von 20 - 50 µm.

Die im Katalog angegebenen technischen Daten gelten für den Motorbetrieb.

Arbeitet der Motor als Pumpe, ist das auf die Antriebswelle wirkende Moment auf den angegebenen kontinuierlichen Maximalwert zu begrenzen. Dabei muss ein Vorspanndruck von 5 - 10 bar, abhängig vom Förderstrom, vorhanden sein (Kavitationsgefahr).

Il est recommandé d'utiliser une huile hydraulique à base minérale contenant au minimum 0,1% d'additif zinc comme produit anti-usure.

La température normale d'utilisation devrait être située entre +30 °C à +60 °C.

La température maximale d'utilisation ne doit pas être supérieure à +90 °C, alors que la température minimale est limitée à -30 °C.

Lorsque la température de service est largement dépassée, la durée de vie de l'huile est fortement diminuée.

Dans la plage de température de service, la viscosité devrait être située entre 20 et 120 mm²/s.

Dans ce but, la filtration est de 20 à 50 µm.

Les caractéristiques techniques indiquées dans le catalogue sont considérées pour une utilisation en fonction moteur.

Si le moteur fonctionne en pompe, il faut limiter le couple à la valeur maximale indiquée. Dans ce cas, en fonction du débit, il faut créer une contre-pression de 5 à 10 bar (danger de cavitation).

It is recommended to use a mineral based hydraulic oil with minimum 0.1% of zinc as anti-wear additive.

Before using other liquids, please consult our engineering department.

Normal working temperatures should be in the range of between +30 °C and +60 °C.

Maximum temperatures must not exceed +90 °C while minimum temperatures should be limited to -30 °C.

If normal working temperatures are substantially exceeded this will result in reduced life duration of the oil used.

Viscosity in the range of working temperatures should be 20 to 120mm²/s.

It is advisable to use a filtering fineness of 20 - 50 µm.

The technical data are applicable to motor operation.

If the motor is used as a pump, the input torque on the coupling shaft must be limited to the indicated continuous maximum value. For this, an inlet pressure of 5 - 10 bar must be applied depending on oil flow (danger of cavitation).

Si consiglia l'impiego di olio idraulico a base di olio minerale con almeno 0,1% di zinco come additivo anti usura. Prima dell'impiego di altri liquidi si prega di contattare il nostro ufficio tecnico.

La temperatura normale di esercizio dovrebbe essere da +30 °C a +60 °C.

La temperatura massima non deve superare +90 °C, mentre la temperatura minima è limitata a -30 °C.

Se la temperatura normale di esercizio viene sostanzialmente superata, la durata dell'olio diminuisce sensibilmente.

La viscosità nel campo della temperatura di esercizio dovrebbe essere da 20 a 120 mm²/s.

Si deve prevedere un sistema filtrante per 20...50 micron.

I dati sopraesposti sono validi negli impieghi come motore. Se il motore viene usato come pompa, la coppia sull'albero deve essere limitata a quella massima ammessa.

Pertanto il motore deve essere pressurizzato a 5...10 bar in funzione della portata d'olio per evitare cavitazione.

TE/TJ	cm ³ /rev	cont/int rev/min	cont / int l / min	cont / int bar	max bar	cont / int Nm	cont / int KW
TE/TJ 36	36	930/1160	35/40	140/190	200	55/71	9
TE/TJ 45	41	810/1024	35/41	140/190	200	70/100	10
TE/TJ 50	50	725/1020	35/50	140/190	200	90/127	13
TE/TJ 65	66	705/940	45/60	140/190	200	125/176	15
TE/TJ 80	82	560/750	45/60	140/190	200	160/220	17
TE/TJ 100	98	470/630	45/60	140/190	200	190/264	17
TE/TJ 130	130	350/470	45/60	140/1960	200	255/352	17
TE/TJ 165	163	280/375	45/60	140/190	200	310/436	17
TE/TJ 195	196	235/315	45/60	140/190	200	390/528	17
TE/TJ 230	228	265/330	60/75	120/165	200	380/514	18
TE/TJ 260	261	230/290	60/75	110/155	200	400/550	17
TE/TJ 295	293	200/255	60/75	100/145	200	428/582	16
TE/TJ 330	326	185/235	60/75	100/135	200	443/600	15
TE/TJ 365	370	150/200	60/75	95/125	200	467/648	14
TE/TJ 390	392	152/190	60/75	85/120	200	445/628	13

Radiale Wellenbelastung
Side loads
Charges latérales
Carico radiale
TE 7.000 N
TJ 14.000 N

TF	cm ³ /rev	cont/int rev/min	cont / int l / min	cont / int bar	max bar	cont / int Nm	cont / int KW
TF 80	81	550/730	45/60	210/280	300	220/295	22
TF 100	100	600/750	60/75	160/240	300	200/320	25
TF 130	128	470/580	60/75	140/210	300	230/360	22
TF 140	141	370/530	60/75	140/210	300	250/390	22
TF 170	169	355/440	60/75	140/210	300	320/490	23
TF 195	197	300/380	60/75	140/210	300	365/560	22
TF 240	238	320/420	75/100	140/210	300	430/670	28
TF 280	280	270/350	75/100	140/210	300	550/800	28
TF 360	364	200/260	75/100	130/190	300	590/910	24
TF 405	405	170/230	75/100	130/175	300	660/920	22
TF 475	477	150/200	75/100	115/140	300	680/850	17

Radiale Wellenbelastung
Side loads
Charges latérales
Carico radiale
TF 16.000 N

TL	cm ³ /rev	cont/int rev/min	cont / int l / min	cont / int bar	max bar	cont / int Nm	cont / int KW
TL 140	140	613	68/95	190/241	300	364/463	30
TL 170	169	512	68/95	190/241	300	449/570	31
TL 195	195	484	68/95	190/241	300	511/648	34
TL 240	238	399	68/95	190/241	300	620/790	34
TL 280	280	335	68/95	190/241	300	730/929	34
TL 310	310	310	68/95	190/241	300	847/1079	36
TL 360	364	255	68/95	172/224	300	890/1163	31

Radiale Wellenbelastung
Side loads
Charges latérales
Carico radiale
TL 16.000 N

int. =

Intermittierende Werte maximal: 10% von jeder Betriebsminute.

Intermittent operation rating applies to 10% of every minute.

Fonctionnement interm.: 10% max. de chaque minute d'utilisation.

Servizio intermittente: 10% max di ogni minuto di utilizzazione.

* Druckdifferenz Δp zwischen Ein- und Ausgang

* Pressure difference is Δp between input and output

* La différence de pression est Δp entre l'entrée et la sortie

* La differenza di pressione corrisponde al Δp tra ingresso e uscita

Achtung: Höhere Drücke auf Anfrage möglich.

Notice: Higher pressures are possible on request.

Remarque : des pressions supérieures sont possibles sur demande.

Nota: Pressioni superiori possibili su richiesta.

Produktübersicht Motor range Gamme de moteurs Serie di motori	Geom. Schluckvolumen Geometric displacement Cylindree Cilindrata	Max. Drehzahl Max. speed Vitesse de rotation maxi Velocità di rotazione max	Max. Schluckstrom Max. oil flow Debit d'huile maxi Portata max	Max. Druckdifferenz * Max. differential pressure * Chute de pression maxi * Caduta di pressione max *	Max. Eingangsdruck Max. supply pressure Pressione maxi entrata Pressione max in entrata	Max. Drehmoment Max. torque Couple maxi Coppia max	Max. Leistungabgabe Max. performance Puissance de sortie maxi Potenza meccanica max
TG	cm ³ /rev	cont/int rev/min	cont / int l / min	cont / int bar	max bar	cont / int Nm	cont / int KW
TG 140	141	530/710	75/100	210/280	300	400/545	33
TG 170	169	440/575	75/100	210/280	300	485/670	33
TG 195	195	380/510	75/100	210/280	300	560/770	33
TG 240	238	320/420	75/100	210/280	300	685/945	32
TG 280	280	270/350	75/100	210/280	300	800/1100	31
TG 335	337	225/290	75/100	210/280	300	980/1350	30
TG 405	405	185/245	75/100	170/240	300	960/1350	27
TG 475	477	160/240	75/115	140/210	300	960/1400	28
TG 530	529	140/215	75/115	140/170	300	1050/1280	23
TG 625	613	120/185	75/115	120/160	300	1040/1360	20
TG 785	786	95/145	75/115	100/140	300	1150/1490	17
TG 960	959	78/119	75/115	70/100	300	925/1390	12

Radiale Wellenbelastung
Side loads
Charges latérales
Carico radiale
TG/BG 16.000 N
TH 30.000 N

TH	cm ³ /rev	cont/int rev/min	cont / int l / min	cont / int bar	max bar	cont / int Nm	cont / int KW
TH 140	141	530/710	75/100	210/280	300	400/545	33
TH 170	169	440/575	75/100	210/280	300	485/670	33
TH 195	195	380/510	75/100	210/280	300	560/770	33
TH 240	238	320/420	75/100	210/280	300	685/945	32
TH 280	280	270/350	75/100	210/280	300	800/1100	31
TH 335	337	225/290	75/100	210/280	300	980/1350	30
TH 405	405	185/245	75/100	170/240	300	960/1350	27
TH 475	477	160/240	75/115	140/210	300	960/1400	28
TH 530	529	140/215	75/115	140/170	300	1050/1280	23
TH 625	613	120/185	75/115	120/160	300	1040/1360	20
TH 785	786	95/145	75/115	100/140	300	1150/1490	17
TH 960	959	78/119	75/115	70/100	300	925/1390	12

Radiale Wellenbelastung
Side loads
Charges latérales
Carico radiale
TG/BG 16.000 N
TH 30.000 N

TK	cm ³ /rev	cont/int rev/min	cont / int l / min	cont / int bar	max bar	cont / int Nm	cont / int KW
TK 250	250	523	114/133	240/310	330	815/1043	49
TK 315	315	413	114/133	240/310	330	1030/1315	47
TK 400	400	373	114/151	205/275	330	1150/1525	49
TK 500	500	300	114/151	205/275	330	1440/1915	48
TK 630	630	240	114/151	205/225	330	1620/1715	34
TK 800	800	276	151/227	190/205	330	1915/2300	44
TK 1000	1000	220	151/227	175/190	330	2410/2660	35

Radiale Wellenbelastung
Side loads
Charges latérales
Carico radiale
TK 26.000 N

int. =

Intermittierende Werte maximal: 10% von jeder Betriebsminute.

Intermittent operation rating applies to 10% of every minute.

Fonctionnement interm.: 10% max. de chaque minute d'utilisation.

Servizio intermittente: 10% max di ogni minuto di utilizzazione.

- * Druckdifferenz Δp zwischen Ein- und Ausgang
- * Pressure difference is Δp between input and output
- * La différence de pression est Δp entre l'entrée et la sortie
- * La differenza di pressione corrisponde al Δp tra ingresso e uscita

Achtung: Höhere Drücke auf Anfrage möglich.

Notice: Higher pressures are possible on request.

Remarque : des pressions supérieures sont possibles sur demande.

Nota: Pressioni superiori possibili su richiesta.

**ACHTUNG — VERANTWORTUNG DES ANWENDERS**

VERSAGEN ODER UNSACHGEMÄßE AUSWAHL ODER UNSACHGEMÄßE VERWENDUNG DER HIERIN BESCHRIEBENEN PRODUKTE ODER ZUGEHÖRIGER TEILE KÖNNEN TOD, VERLETZUNGEN VON PERSONEN ODER SACHSCHÄDEN VERURSACHEN.

Dieses Dokument und andere Informationen von der Parker-Hannifin Corporation, seinen Tochtergesellschaften und Vertragshändlern enthalten Produkt- oder Systemoptionen zur weiteren Untersuchung durch Anwender mit technischen Kenntnissen. Der Anwender ist durch eigene Untersuchung und Prüfung allein dafür verantwortlich, die endgültige Auswahl des Systems und der Komponenten zu treffen und sich zu vergewissern, dass alle Leistungs-, Dauerfestigkeits-, Wartungs-, Sicherheits- und Warnanforderungen der Anwendung erfüllt werden. Der Anwender muss alle Aspekte der Anwendung genau untersuchen, geltenden Industrienormen folgen und die Informationen in Bezug auf das Produkt im aktuellen Produktkatalog sowie alle anderen Unterlagen, die von Parker oder seinen Tochtergesellschaften oder Vertragshändlern bereitgestellt werden, zu beachten. Soweit Parker oder seine Tochtergesellschaften oder Vertragshändler Komponenten oder Systemoptionen basierend auf technischen Daten oder Spezifikationen liefern, die vom Anwender beigestellt wurden, ist der Anwender dafür verantwortlich festzustellen, dass diese technischen Daten und Spezifikationen für alle Anwendungen und vernünftigerweise vorhersehbaren Verwendungszwecke der Komponenten oder Systeme geeignet sind und ausreichen.

Verkaufs-Angebot

Wenden Sie sich bitte wegen eines ausführlichen Verkaufs-Angebotes an Ihre Parker-Vertretung.

**WARNING - USER RESPONSIBILITY**

FAILURE OR IMPROPER SELECTION OR IMPROPER USE OF THE PRODUCTS DESCRIBED HEREIN OR RELATED ITEMS CAN CAUSE DEATH, PERSONAL INJURY AND PROPERTY DAMAGE.

This document and other information from Parker-Hannifin Corporation, its subsidiaries and authorized distributors provide product or system options for further investigation by users having technical expertise.

The user, through its own analysis and testing, is solely responsible for making the final selection of the system and components and assuring that all performance, endurance, maintenance, safety and warning requirements of the application are met. The user must analyze all aspects of the application, follow applicable industry standards, and follow the information concerning the product in the current product catalog and in any other materials provided from Parker or its subsidiaries or authorized distributors.

To the extent that Parker or its subsidiaries or authorized distributors provide component or system options based upon data or specifications provided by the user, the user is responsible for determining that such data and specifications are suitable and sufficient for all applications and reasonably foreseeable uses of the components or systems.

Offer of Sale

Please contact your Parker representation for a detailed "Offer of Sale".

**AVERTISSEMENT — RESPONSABILITE DE L'UTILISATEUR**

LA DÉFECTUOSITÉ OU LA SÉLECTION OU L'USAGE ABUSIF DES PRODUITS DÉCRITS DANS LE PRÉSENT DOCUMENT OU D'ARTICLES ASSOCIÉS PEUT ENTRAÎNER LA MORT, DES BLESSURES ET DES DOMMAGES MATÉRIELS.

Ce document et d'autres informations de Parker-Hannifin Corporation, ses filiales et distributeurs autorisés, proposent des options de produit et de système destinées aux utilisateurs possédant de solides connaissances techniques.

En procédant à ses propres analyses et essais, l'utilisateur est seul responsable de la sélection définitive du système et des composants, au même titre qu'il lui incombe de veiller à la satisfaction des exigences en matière de performances, endurance, entretien, sécurité et avertissement. L'utilisateur doit analyser tous les aspects de l'application, suivre les normes applicables de l'industrie et les informations concernant le produit dans le catalogue de produits actuel et dans tout autre document fourni par Parker, ses filiales ou distributeurs agréés.

Dans la mesure où Parker ou ses filiales ou distributeurs agréés fournissent des options de système ou de composant se basant sur les données ou les spécifications indiquées par l'utilisateur, c'est à celui-ci qu'incombe la responsabilité de déterminer si ces données et spécifications conviennent et sont suffisantes pour toutes les applications et utilisations raisonnablement prévisibles des composants ou des systèmes.

Offre de vente

Veillez contacter votre représentant Parker pour obtenir une « Offre de vente » détaillée.

**AVVERTENZA - RESPONSABILITÀ DELL'UTENTE**

UN Malfunzionamento, una scelta inappropriata o l'uso improprio dei prodotti ivi descritti o dei componenti correlati possono causare decesso, lesioni personali e danni al patrimonio.

- Il presente documento e le altre informazioni divulgate da Parker Hannifin Corporation, dalle sue consociate e dai distributori autorizzati forniscono opzioni di prodotti o sistemi che devono essere ulteriormente analizzate da utenti con competenze tecniche.

- L'utente, attraverso processi di analisi e verifica, si assume la responsabilità assoluta per la scelta finale del sistema e dei componenti e per garantire che vengano soddisfatti tutti i requisiti dell'applicazione in merito a performance, resistenza, manutenzione, sicurezza e avvertenze. L'utente ha l'obbligo di analizzare tutti gli aspetti dell'applicazione, attenersi agli standard di settore applicabili e seguire le informazioni sul prodotto incluse nel catalogo dei prodotti corrente e in qualsiasi altro materiale fornito da Parker o dalle sue consociate o dai distributori autorizzati.

- Nella misura in cui Parker o le sue consociate o i distributori autorizzati forniscono opzioni di componenti o sistemi in base alle informazioni o alle specifiche indicate dall'utente, l'utente ha la responsabilità di verificare che tali informazioni e specifiche siano appropriate e sufficienti per tutte le applicazioni e gli usi ragionevolmente prevedibili dei componenti o dei sistemi.

Preventivo

Rivolgersi al proprio rappresentante Parker per un "Preventivo" dettagliato.

Parker Worldwide

Europe, Middle East, Africa

AE – United Arab Emirates,
Dubai

Tel: +971 4 8127100
parker.me@parker.com

AT – Austria, Wiener Neustadt
Tel: +43 (0)2622 23501-0
parker.austria@parker.com

AT – Eastern Europe, Wiener
Neustadt
Tel: +43 (0)2622 23501 900
parker.easteurope@parker.com

AZ – Azerbaijan, Baku
Tel: +994 50 2233 458
parker.azerbaijan@parker.com

BE/LU – Belgium, Nivelles
Tel: +32 (0)67 280 900
parker.belgium@parker.com

BY – Belarus, Minsk
Tel: +375 17 209 9399
parker.belarus@parker.com

CH – Switzerland, Etoy
Tel: +41 (0)21 821 87 00
parker.switzerland@parker.com

CZ – Czech Republic, Klecany
Tel: +420 284 083 111
parker.czechrepublic@parker.com

DE – Germany, Kaarst
Tel: +49 (0)2131 4016 0
parker.germany@parker.com

DK – Denmark, Ballerup
Tel: +45 43 56 04 00
parker.denmark@parker.com

ES – Spain, Madrid
Tel: +34 902 330 001
parker.spain@parker.com

FI – Finland, Vantaa
Tel: +358 (0)20 753 2500
parker.finland@parker.com

FR – France, Contamine s/Arve
Tel: +33 (0)4 50 25 80 25
parker.france@parker.com

GR – Greece, Athens
Tel: +30 210 933 6450
parker.greece@parker.com

HU – Hungary, Budapest
Tel: +36 1 220 4155
parker.hungary@parker.com

IE – Ireland, Dublin
Tel: +353 (0)1 466 6370
parker.ireland@parker.com

IT – Italy, Corsico (MI)
Tel: +39 02 45 19 21
parker.italy@parker.com

KZ – Kazakhstan, Almaty
Tel: +7 7272 505 800
parker.easteurope@parker.com

NL – The Netherlands, Oldenzaal
Tel: +31 (0)541 585 000
parker.nl@parker.com

NO – Norway, Asker
Tel: +47 66 75 34 00
parker.norway@parker.com

PL – Poland, Warsaw
Tel: +48 (0)22 573 24 00
parker.poland@parker.com

PT – Portugal, Leca da Palmeira
Tel: +351 22 999 7360
parker.portugal@parker.com

RO – Romania, Bucharest
Tel: +40 21 252 1382
parker.romania@parker.com

RU – Russia, Moscow
Tel: +7 495 645-2156
parker.russia@parker.com

SE – Sweden, Spånga
Tel: +46 (0)8 59 79 50 00
parker.sweden@parker.com

SK – Slovakia, Banská Bystrica
Tel: +421 484 162 252
parker.slovakia@parker.com

SL – Slovenia, Novo Mesto
Tel: +386 7 337 6650
parker.slovenia@parker.com

TR – Turkey, Istanbul
Tel: +90 216 4997081
parker.turkey@parker.com

UA – Ukraine, Kiev
Tel: +380 44 494 2731
parker.ukraine@parker.com

UK – United Kingdom, Warwick
Tel: +44 (0)1926 317 878
parker.uk@parker.com

ZA – South Africa, Kempton Park
Tel: +27 (0)11 961 0700
parker.southafrica@parker.com

North America

CA – Canada, Milton, Ontario
Tel: +1 905 693 3000

US – USA, Cleveland
(industrial)
Tel: +1 216 896 3000

US – USA, Elk Grove Village
(mobile)
Tel: +1 847 258 6200

Asia Pacific

AU – Australia, Castle Hill
Tel: +61 (0)2-9634 7777

CN – China, Shanghai
Tel: +86 21 2899 5000

HK – Hong Kong
Tel: +852 2428 8008

IN – India, Mumbai
Tel: +91 22 6513 7081-85

JP – Japan, Fujisawa
Tel: +81 (0)4 6635 3050

KR – South Korea, Seoul
Tel: +82 2 559 0400

MY – Malaysia, Shah Alam
Tel: +60 3 7849 0800

NZ – New Zealand, Mt Wellington
Tel: +64 9 574 1744

SG – Singapore
Tel: +65 6887 6300

TH – Thailand, Bangkok
Tel: +662 717 8140

TW – Taiwan, Taipei
Tel: +886 2 2298 8987

South America

AR – Argentina, Buenos Aires
Tel: +54 3327 44 4129

BR – Brazil, Sao Jose dos
Campos
Tel: +55 12 4009 3500

CL – Chile, Santiago
Tel: +56 2 623 1216

MX – Mexico, Apodaca
Tel: +52 81 8156 6000

VE – Venezuela, Caracas
Tel: +58 212 238 5422

EMEA Product Information Centre

Free phone: 00 800 27 27 5374

(from AT, BE, CH, CZ, DE, DK, EE, ES, FI, FR, IE, IL,
IS, IT, LU, MT, NL, NO, PL, PT, RU, SE, SK, UK, ZA)

US Product Information Centre

Toll-free number: 1-800-27 27 537

www.parker.com

