

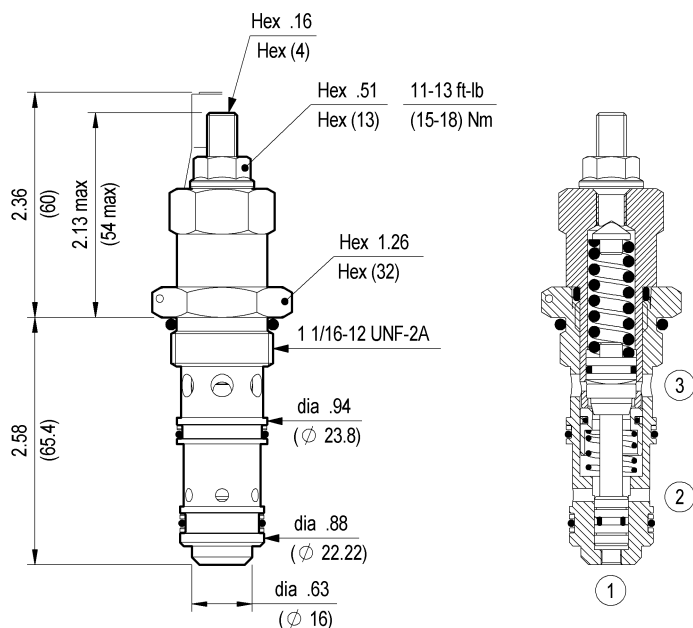

**COUNTERBALANCE, STANDARD POPPET TYPE
DIFFERENTIAL AREA
SPECIAL CAVITY**

VBSO-SEC-30

04.52.04 - X - 99 - Z



Inches
(mm)

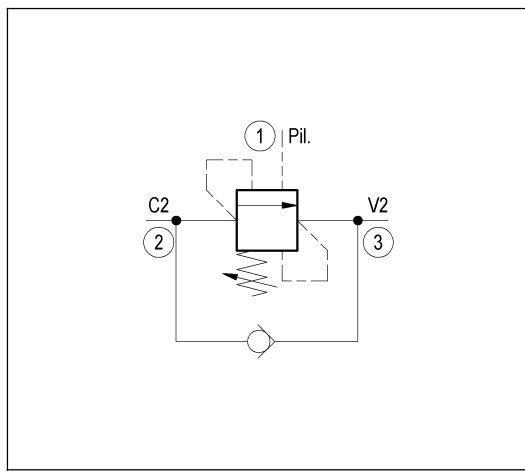

TECHNICAL DATA

Max. pressure:	5000 psi	(350 bar)
Max. flow:	16 gpm	(60 l/min)
Special cavity :	063 (see page CT.S.002.U)	
Installation torque :	86-95 ft-lb	(116-128 Nm)
Weight:	0.551 lbs	(0.250 Kg)

Pressure setting: at least 1.3 times the load induced pressure

When pressure at 3 rises above the spring bias pressure, the check seat is pushed away from the piston and flow is allowed from 3 to 2. When load pressure at 2 rises above the pressure setting, the direct-acting, differential area relief function is activated and flow is relieved from 2 to 3. With pilot pressure at 1, the pressure setting is reduced in proportion to the stated ratio of the valve, until fully open with free-flow from 2 to 3. The spring chamber is drained to 3, and any back-pressure at 3 is additive to the pressure setting in all functions.

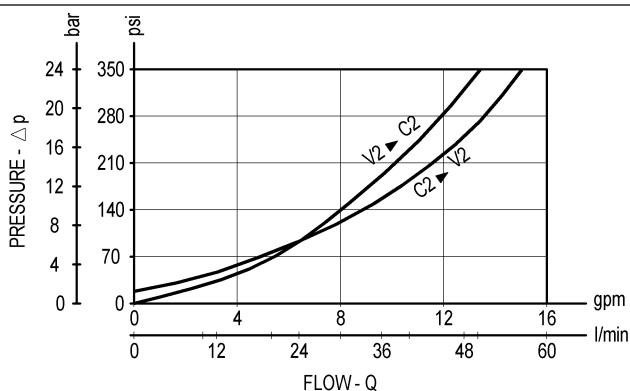

X PILOT RATIO

03 4.2 : 1

SPRINGS

Z	Adj. press. range psi (bar)	Press. increase psi / turn (bar/turn)	Standard setting psi (bar) (Q=5 l/min)
20	870-3000 (60-210)	812 (56)	2900 (200)
35	1450-5000 (100-350)	2001 (138)	5000 (350)

OPTIONS

Ordering code	Description
11.04.23.002	Sealing cap

Special settings available. Contact factory authorized representative for ordering code.