

Counterbalance, standard poppet type
differential area
Common cavity, Size 20

VBSN-20A

04.52.25 - X - 58 - Z

RE 18320-05

Edition: 01.2021

Replaces: 06.2020

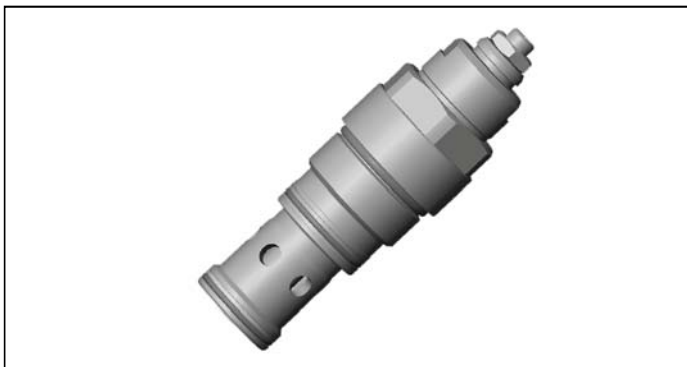

Technical data	
Max. operating pressure	350 bar (5000 psi)
Max. flow	320 l/min (85 gpm)
Max. internal leakage ¹⁾	15 drops/min.
Fluid temperature range	-30 to 100 °C (-22 to 212 °F)
Installation torque	128 - 149 Nm (95 - 110 ft-lbs)
Weight	1.12 kg (2.5 lbs)
MTTFD	150 years see RE 18350-51
Cavity	CA-20A-3C (see data sheet 18325-70)
Adjustment	according to ISO 4413 with sealed adjustment screw to prevent oil leakage during adjustment
Salt spray test	500h according to DIN EN ISO 9227:2017-07
Lines bodies and standard assemblies	Please refer to section "Hydraulic integrated circuit" or consult factory
Seal kit ²⁾	Code: RG20A9010530100 material no: R90111397
Fluids	Mineral-based or synthetics with lubricating properties at viscosities of 10 to 500 mm ² /s (cSt)
Recommended degree of fluid contamination	Nominal value max. 10µm (NAS 8) / ISO 4406 19/17/14
Installation position	No restrictions
Other Technical Data	See data sheet 18350-50

Description

When pressure at 2 rises above the spring bias pressure, the check seat is pushed away from the piston and flow is allowed from 2 to 1. When load pressure at 1 rises above the pressure setting, the direct-acting, differential area relief function is activated and flow is relieved from 1 to 2. With pilot pressure at 3, the pressure setting is reduced in proportion to the stated ratio of the valve, until fully open with free-flow from 1 to 2. The spring chamber is drained to 2, and any back-pressure at 2 is additive to the pressure setting in all functions. Valve design prevents spring going solid and complete unscrewing during adjusting.

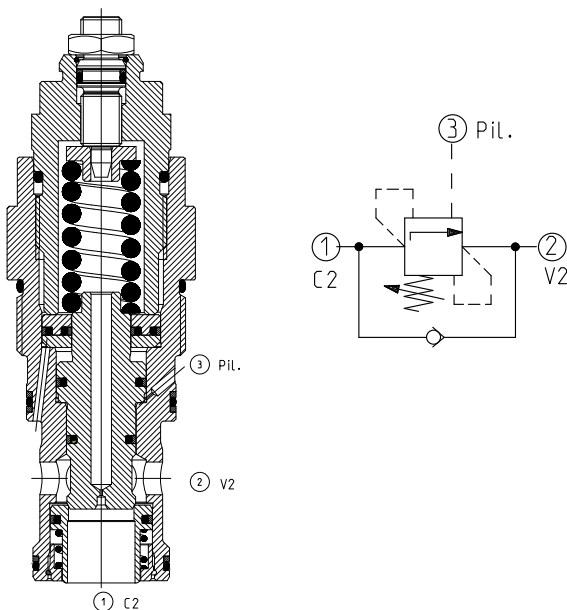

Pressure setting: at least 1.3 times the load induced pressure and maximum 1.5 times catalogue max nominal setting.

- 1) At 70% of pressure setting
- 2) Only external seals for 10 valves

Characteristic curve

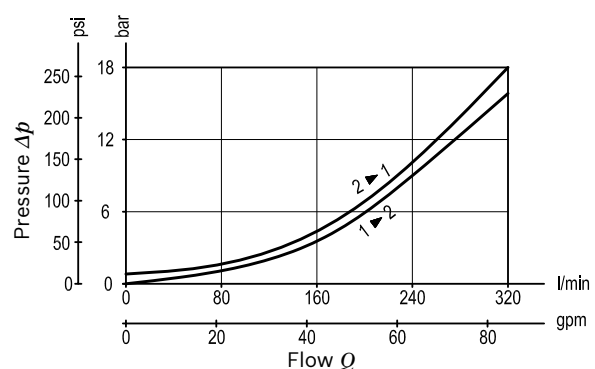

Ordering code

04.52.25	X	58	Z	*	*
-----------------	----------	-----------	----------	----------	----------

Counterbalance,
standard poppet type, differential area

Pilot ratio

03 4:1

10 8:1

58 Common cavity, Size 20

Series M to Z
unchanged performances and dimensions

00 Standard (Buna)
V0 Viton (FKM)

		SPRINGS		
		Adj. press. range bar (psi)	Pressure increase bar/turn (psi/turn)	Std. setting bar (psi) Q=5 l/min
for X= 03	20	70-210 (1000-3000)	70 (1015)	200 (2900)
	35	140-350 (2000-5000)	108 (1566)	350 (5000)
for X= 10	40	140-420 (2000-6000)	135 (1958)	350 (5000)

Note: Special settings available with optional tamperproof cap. Contact factory authorized representative for ordering code.

Preferred types

Type	Material number
04522503582000M	R930081294
04522503583500M	R930081295
04522510584000M	R930081296

Type	Material number

Dimensions

Technical drawing of the counterbalance valve showing dimensions and options. The drawing includes the following labels and dimensions:

- Hex 5 (0.2)
- Hex 16 15 Nm
Hex (0.63) (1) ft-lb
- Across Flat 30 (1.18)
- Hex 41 (1.61)
- Ø46 (1.81)
- 1 5/8-12 UN-2A
- Ø36.52 (1.44)
- Ø33.35 (1.31)
- 66 (2.59) max
- 64.5 (2.53) max
- 73.5 (2.89)

OPTION 1
Protection cap orange
Mat. no. R900168151

OPTION 2
Tamperproof cap red (without Rexroth logo)
Mat. no. R93xxxxxxx

Bosch Rexroth Oil Control S.p.A.

Via Leonardo da Vinci 5
P.O. Box no. 5
41015 Nonantola – Modena, Italy
Tel. +39 059 887 611
Fax +39 059 547 848
compact-hydraulics-cv@boschrexroth.com
www.boschrexroth.com/compacthydraulics

© This document, as well as the data, specifications and other information set forth in it, are the exclusive property of Bosch Rexroth Oil Control S.p.a.. It may not be reproduced or given to third parties without its consent. The data specified above only serve to describe the product. No statements concerning a certain condition or suitability for a certain application can be derived from our information. The information given does not release the user from the obligation of own judgment and verification. It must be remembered that our products are subject to a natural process of wear and aging. Subject to change.