

Counterbalance, relief compensated
poppet type differential area, counterclockwise adjustment
Sun cavity interchange, T-2A

VBSP-12U-RS

04.54.16 - X - 86 - Z

RE 18320-21

Edition: 11.2019

Replaces: 06.2019



Technical data	
Max. operating pressure	350 bar (5000 psi)
Max. flow	120 l/min (32 gpm)
Max. internal leakage ¹⁾	5 drops/min.
Fluid temperature range	-30 to 100 °C (-22 to 212 °F)
Installation torque	60 - 70 Nm (44 - 52 ft-lbs)
Weight	0.37 kg (0.82 lbs)
Cavity	SUN T-2A
Lines bodies and standard assemblies	Please refer to section "Hydraulic integrated circuit" or consult factory
Seal kit ²⁾	Code: RG12U9020110100 material no: R930005599
Fluids	Mineral-based or synthetics with lubricating properties at viscosities of 10 to 500 mm ² /s (cSt)
Recommended degree of fluid contamination	Nominal value max. 10µm (NAS 8) / ISO 4406 19/17/14
Installation position	No restrictions
Other Technical Data	See data sheet 18350-50

Pressure setting: at least 1.3 times the load induced pressure.

- 1) At 70% of pressure setting
- 2) Only external seals for 10 valves

Description

When pressure at 2 rises above the spring bias pressure, the check seat is pushed away from the piston and flow is allowed from 2 to 1. When load pressure at 1 rises above the pressure setting (turn counterclockwise to increase setting - turn clockwise to decrease setting), the direct-acting, differential area relief function is activated and flow is relieved from 1 to 2. With pilot pressure at 3, the pressure setting is reduced in proportion to the stated ratio of the valve, until fully open with free-flow from 1 to 2. The valve applies a balanced piston design allowing relief operation at the valve setting independent of back-pressure at 2. However, the piloted opening of the valve remains subject to additive pressure at port 2.

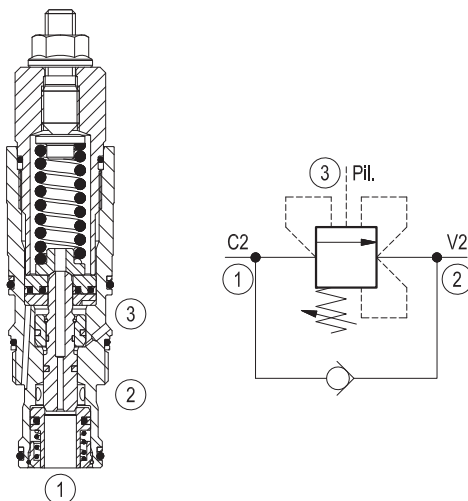

Characteristic curve

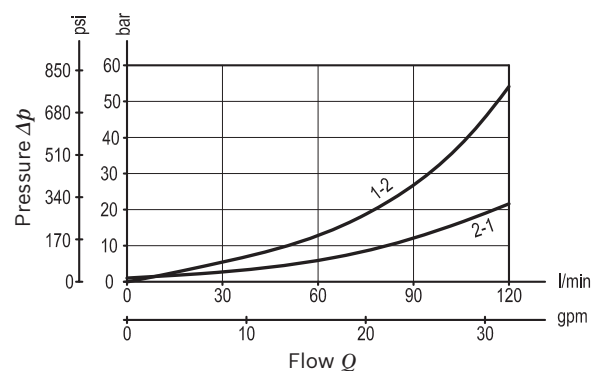

Ordering code

04.54.16	X	86	Z	00	*
-----------------	----------	-----------	----------	-----------	----------

Counterbalance, relief compensated, poppet type differential area, counterclockwise adjustment

Pilot ratio

03 4:1 Without sealed pilot piston

86 SUN cavity interchange, T-2A

Series 0/A to L unchanged performances and dimensions

Version and options standard

	SPRINGS		
	Adj. press. range bar (psi)	Pressure increase bar/turn (psi/turn)	Std. setting bar (psi) cracking pressure
20	70-210 (1000-3000)	40 (580)	200 (2900)
35	140-350 (2000-5000)	125 (1813)	350 (5000)

Note: Special settings available. Contact factory authorized representative for ordering code.

Preferred types

Type	Material number
045416038620000	R930006124
045416038635000	R930006125

Type	Material number

Dimensions

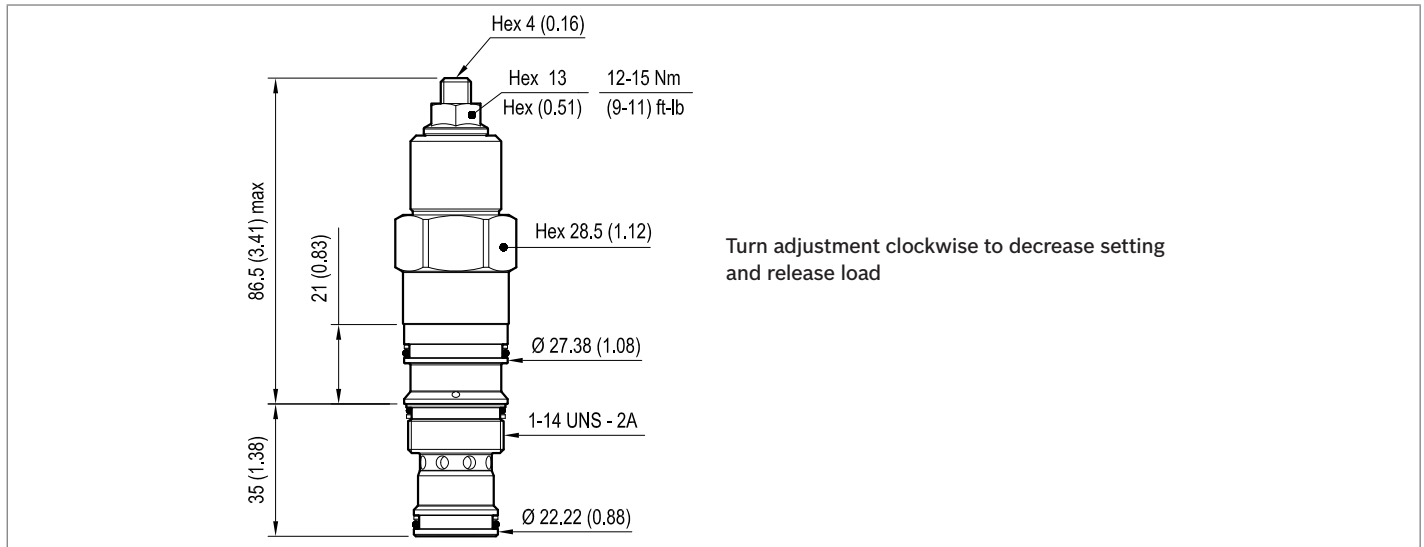

Bosch Rexroth Oil Control S.p.A.

Via Leonardo da Vinci 5
 P.O. Box no. 5
 41015 Nonantola – Modena, Italy
 Tel. +39 059 887 611
 Fax +39 059 547 848
 compact-hydraulics-cv@boschrexroth.com
 www.boschrexroth.com/compacthydraulics

© This document, as well as the data, specifications and other information set forth in it, are the exclusive property of Bosch Rexroth Oil Control S.p.a.. It may not be reproduced or given to third parties without its consent. The data specified above only serve to describe the product. No statements concerning a certain condition or suitability for a certain application can be derived from our information. The information given does not release the user from the obligation of own judgment and verification. It must be remembered that our products are subject to a natural process of wear and aging. Subject to change.