

PRESSIONE TARATURA SETTING	ATTACCHI PORT SIZES
VALVOLA / VALVE : 250 bar (cracking pressure)	V1-V2-C1-C2 : G3/8 ISO1179-1

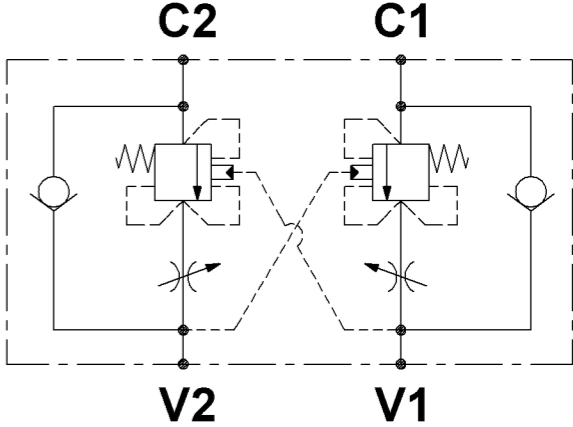
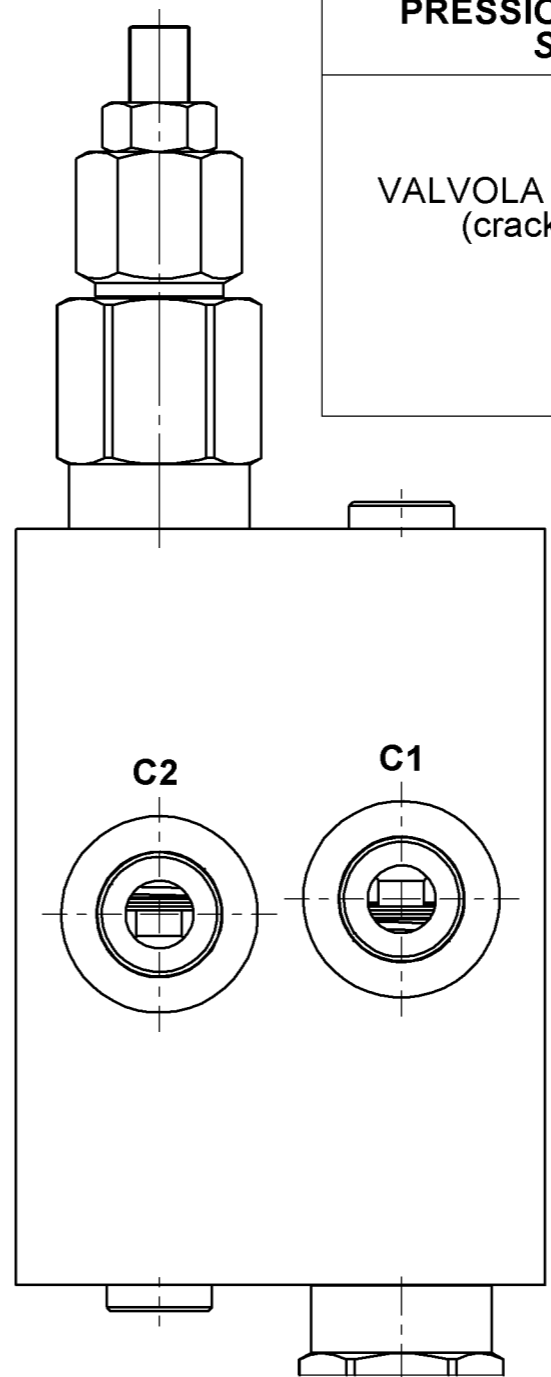

Pos.	Codice Code	Material number	Descrizione Description	Q.tà Q.ty
1	033012695000000		COLL.VBSO-DE30-CC-PL-38	1
2	045525030004000		xVBSO-SE30CC-PL-4,2;;1-35-04	2
3	110407002000000	R930030730	TAPPO EXPANDER D5MB800-50	2
4	110408001000000	R930000750	TAPPO CON GUARNIZ.1/8"GAS	2

MODIFICHE
CHANGES

Denominazione / Denomination VBSO-DE30CC-4.2:1-38-35		Rexroth Bosch Group Bosch Rexroth Oil Control S.p.A. Ufficio Tecnico DC-MA/ENG14 Gerarchia Prodotto 876209309 Product Hierarchy	
Specifiche Specifications	-	Kit guarniz. Seal kit	-
Massa / Mass (kg)	1,500	Modifiche Changes	
Richiesta / Request	23477.33901	Sostituisce Replaces	
Tipo cavità Cavity type	A3	Codice Code	054486030235000
Disegnato / Designed by Rebecchi Data / Date 22/12/16		Material number	R930058643
Verificato / Checked by Bruni Scala / Scale 1:1		Direttorio del file Cad / Cad file directory K:\Design\Cad 3D\complessivi\054486030235000	

Disegno di proprietà BOSCH REXROTH OIL CONTROL S.p.A. tutelato ai termini di legge. E' vietata la riproduzione e la diffusione non autorizzata.
This drawing is a property of BOSCH REXROTH OIL CONTROL S.p.A. protected according to the laws. Unauthorized reproduction and distribution is strictly prohibited.