

Pilot operated check, single

VSO-SE-FC1

05.52.02 - X - Y - Z

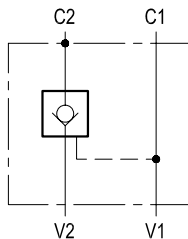

Description

Flow is allowed to pass from V2 to C2 when pressure at V2 rises above the spring bias pressure and the poppet is pushed from its seat. The valve is normally closed (checked) from C2 to V2; when sufficient pilot pressure is present at V1-C1 the pilot piston acts to push the poppet from its seat and flow is allowed from C2 to V2. Precision machining and hardening processes allow virtually leak-free performance in the checked condition. For better safety and compact assembly, the C2 port is flanged (gasket mounted) directly on the actuator.

Performance

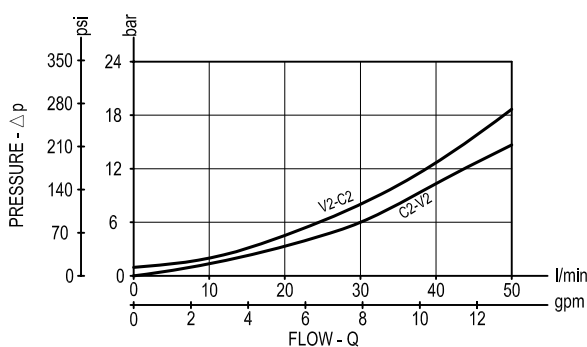

Technical data

Hydraulic

Operating pressure	bar (psi)	up to 210 (3000)
Max. flow	l/min (gpm)	50 (13)

The version with O-Ring and heavier spring is generally recommended.

General

Manifold material	Aluminium	
Note: aluminium bodies are often strong enough for operating pressures exceeding 210 bar (3000 psi), depending from the fatigue life expected in the specific application. If in doubt, consult our Service Network.		
Weight	kg (lbs)	0.72 (1.59)
Fluid temperature range	°C (°F)	between -30 (-22) and +100 (212)
Other technical data	see data sheet RE 18350-50	

Note: for applications outside these parameters, please consult us.

Dimensions

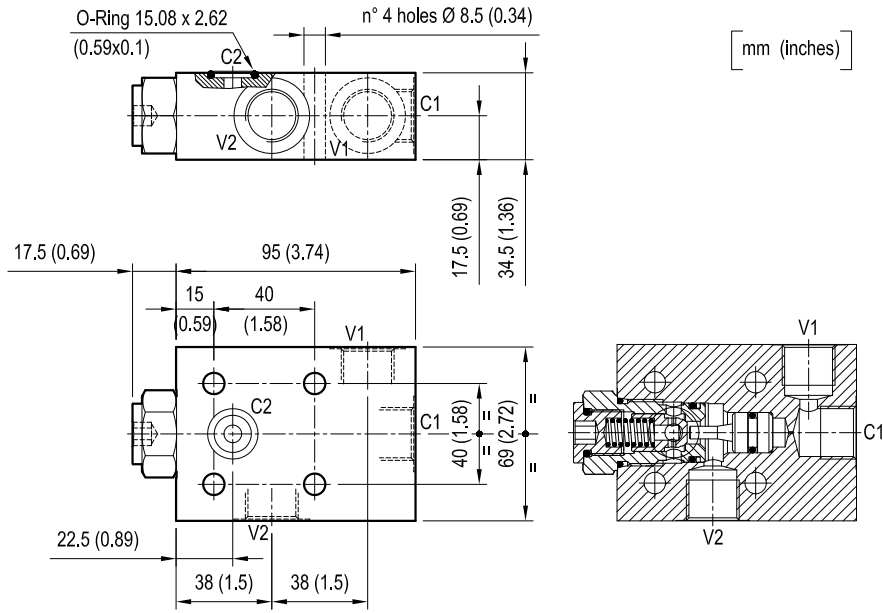

Ordering code

05.52.02	X	Y	Z
-----------------	----------	----------	----------

Pilot operated check, single

O-Ring on pilot piston	Pilot ratio
= 00 No O-Ring	3.2 : 1
= 10 With O-Ring	3.2 : 1
= 25 With O-Ring	6 : 1

Port sizes	V1 - V2	C1	C2
= 03	G 1/2	G 1/2	Ø 7 (0.28)

Type	Material number
05520200030000A	R930002310
055202100301000	R930002313
055202250301000	R930002314

SPRINGS	
Cracking pressure bar (psi)	
= 00 only for X=00	1 (15)
= 01 only for X=10 and X=25	8 (116)

Type	Material number