

RE 18307-08/04.10

1/2

Replaces: RE 00171/02.07

Pilot operated check, single

VSO-SE-DL

05.52.11 - X - 03 - Z

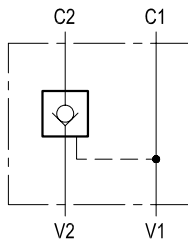

Description

Flow is allowed to pass from V2 to C2 when pressure at V2 rises above the spring bias pressure and the poppet is pushed from its seat. The valve is normally closed (checked) from C2 to V2; when sufficient pilot pressure is present at V1-C1 the pilot piston acts to push the poppet from its seat and flow is allowed from C2 to V2. Precision machining and hardening processes allow virtually leak-free performance in the checked condition.

Performance

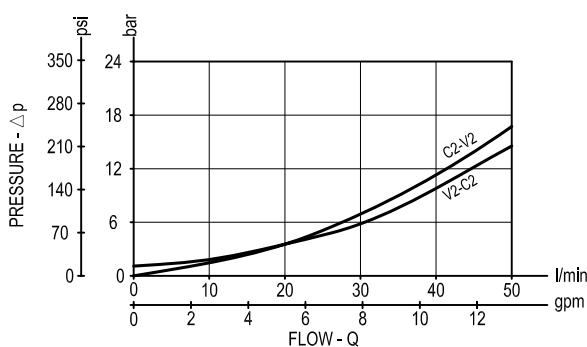

Technical data

Hydraulic

Operating pressure	bar (psi)	up to 210 (3000)
--------------------	-----------	------------------

Max. flow	l/min (gpm)	50 (13)
-----------	-------------	---------

The version with O-Ring and heavier spring is generally recommended.

General

Manifold material	Aluminium
-------------------	-----------

Note: aluminium bodies are often strong enough for operating pressures exceeding 210 bar (3000 psi), depending from the fatigue life expected in the specific application. If in doubt, consult our Service Network.

Weight	kg (lbs)	0.49 (1.09)
--------	----------	-------------

Fluid temperature range	°C (°F)	between -30 (-22) and +100 (212)
-------------------------	---------	----------------------------------

Other technical data	see data sheet RE 18350-50
----------------------	----------------------------

Note: for applications outside these parameters, please consult us.

Dimensions

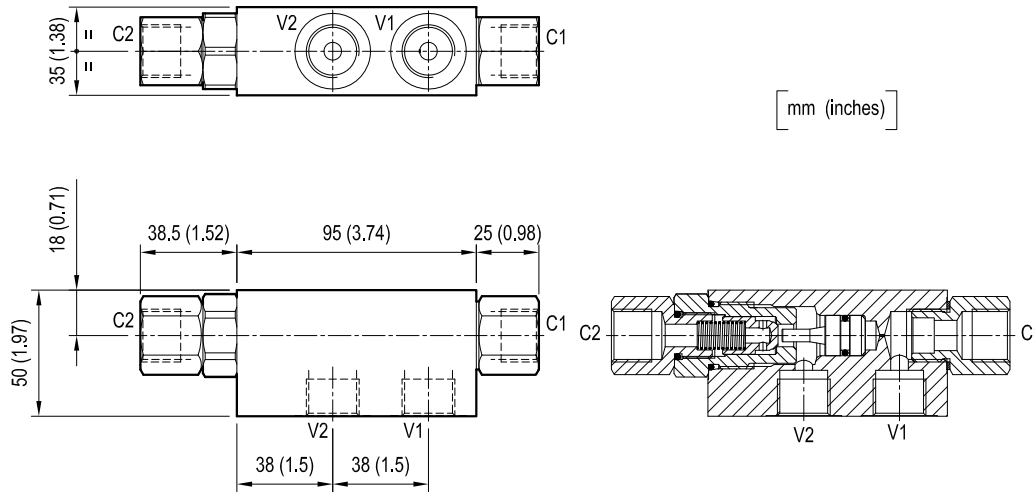

Ordering code

05.52.11	X	03	Z
-----------------	----------	-----------	----------

Pilot operated check, single

O-Ring on pilot piston		Pilot ratio
= 00	No O-Ring	3.2 : 1
= 10	With O-Ring	3.2 : 1
= 25	With O-Ring	6 : 1

Port sizes	V1 - V2	C1 - C2
	G 1/2	G 1/2

SPRINGS

		Cracking pressure bar (psi)
= 00	for X=00	1 (15)
= 01	for X=10	8 (116)
= 00	for X=25	8 (116)

Type	Material number
05521100030000B	R930002317
0552110030100A	R930002321
05521125030000A	R930002327

Type	Material number