

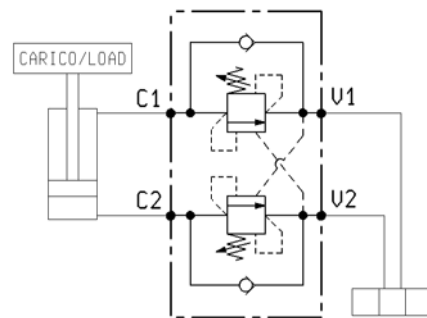

**BILANCIAMENTO, DOPPIO EFFETTO
DUAL PILOT ASSISTED OVERCENTRE**

A-VBSO-DE-12-35

08.42.01.03.03.35.000

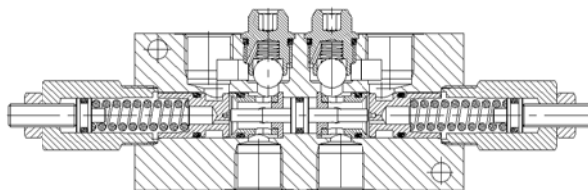
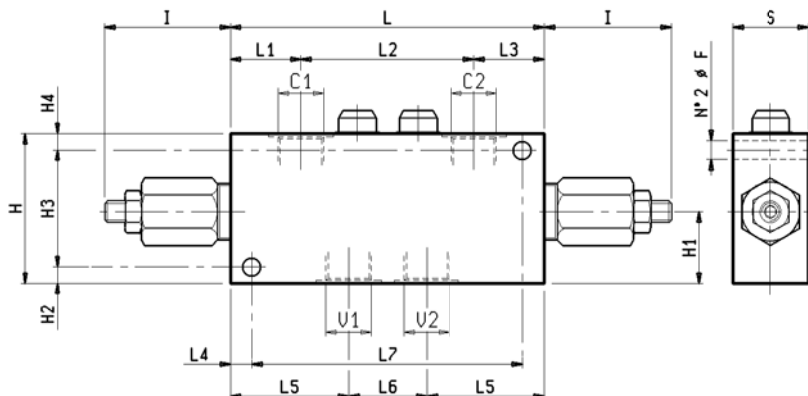

Pressione di lavoro max. 350 bar
Max. working pressure 350 bar

Portata max. vedi diagramma
Flow see performance graph

Taratura della valvola: almeno 1.3 volte superiore alla pressione indotta dal carico
Pressure setting: at least 1.3 times the load induced pressure

Cappellotto per piombatura Codice/Ordering code
Sealing Cap 030501001

35	125	36	54,5	10	32,5	80	32,5	145	60	8	54	8	32	70	8,5	1/2"	
S	L7	L6	L5	L4	L3	L2	L1	L	I	H4	H3	H2	H1	H	F	Y	peso kg weight kg

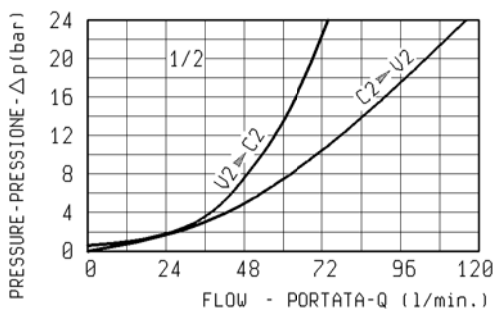

**RAPPORTO DI PILOTAGGIO
PILOT RATIO**

8.2:1

MOLLE/SPRINGS

Campo taratura min-max bar Adj.press. range bar	Incremento pressione bar/giro vite Pressure increase bar/turn	Taratura standard bar (Q=5 l/min) Std. setting bar (made at= 5 l/min)	Codice ordinazione Ordering code	Colore Colour
120-350	106	350	03.51.01.014	giallo yellow

ATTACCHI/PORT SIZE

V1 - V2 - C1 - C2
G 1/2