

Check and metering valve flangeable

A-VBC-42-FC

08.47.85 - X - 73 - Z

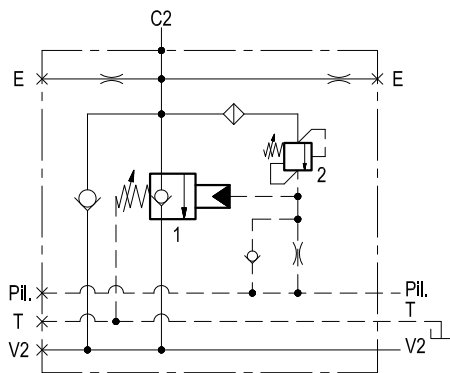
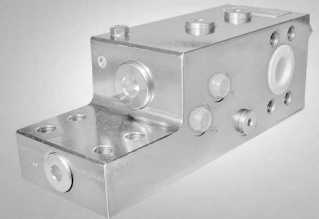

Description

Upstream flow (V2 - C2) to the cylinder is free through the 2 check valves, and reverse flow (C2 - V2) is locked/metered by a leak free spool (1) which provides fine metering in the initial opening stroke. The spool, normally held closed by an adjustable spring force, is remotely controlled by joystick pilot pressure; the pilot pressure required to move the spool is load independent because the spring is vented to Tank. The valve includes a small relief cartridge (2) which senses C2 pressure and opens under overload or shock conditions in order to pilot wide open the metering spool and to allow cylinder pressure to be relieved downstream through the main hose (V2) and through the main control valve. For better safety and compact assembly, the C2 port is gasket mounted directly on the actuator.

Technical data

Hydraulic

Max. operating pressure	bar (psi)	420 (6000)
Max. flow	l/min (gpm)	400 (106)

This valve is designed to be flange mounted on boom cylinders of hydraulic excavators, and, with specific adjustments, it can become part of load holding and load lowering systems designed to comply with ISO Standard 8643 (hose burst protection).

Note: the Tank vented port must be connected to a "low pressure tank line" (to the joystick tank line, or to tank directly).

The restricted "E" port must be connected to a "pressure equalizing line" in case of 2 valves fitted to 2 twin cylinders, and may be used as "outlet to tank" for emergency boom lowering in case of pilot pressure failure.

Performance

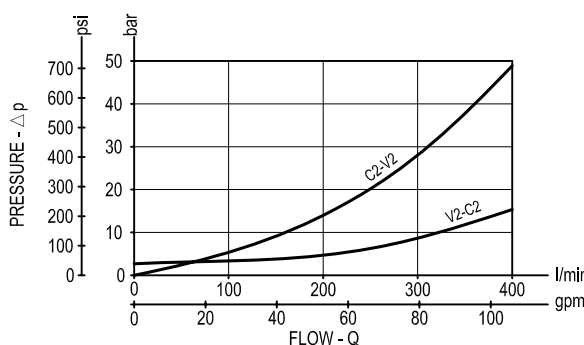

General

Manifold material		Steel
Weight	kg (lbs)	12 (26.5)
Fluid temperature range	°C (°F)	between -30 (-22) and +100 (212)
Other technical data		see data sheet RE 18350-50

Note: for applications outside these parameters, please consult us.

Dimensions

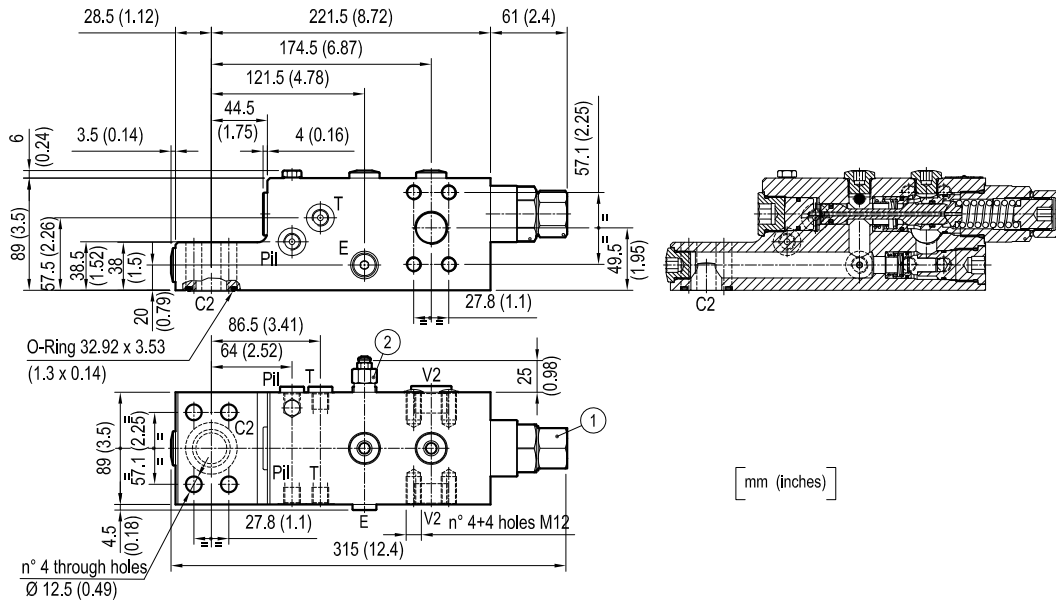

[mm (inches)]

Ordering code

08.47.85	X	73	Z
----------	---	----	---

Check and metering valve flangeable

Adjustments

= 03 Leakproof inner hex. socket screw

Port sizes	V2 - C2	E - Pil - T
	1" SAE 6000	G 1/4

		SPRINGS		
		Adj. pressure range bar (psi)	Pres. increase bar/turn (psi/turn)	Std. setting bar (psi)
= 40	Valve 1	6-15 (87-220)	3.5 (51)	7.5 (109) "cracking"
	Valve 2	350-460 (5000-6600)	228 (3306)	350 (5000) "5 l/min"

Tamper resistant cap code 11.04.31.001 R930000777 for Valve 2



Type	Material number
08478503734000C	R930006450

Type	Material number