

Dual counterbalance

A-VBSO-DE-30-FCB-PI

08.48.12 - X - Y - Z

RE 18307-73

Edition: 03.2021

Replaces: 03.2016

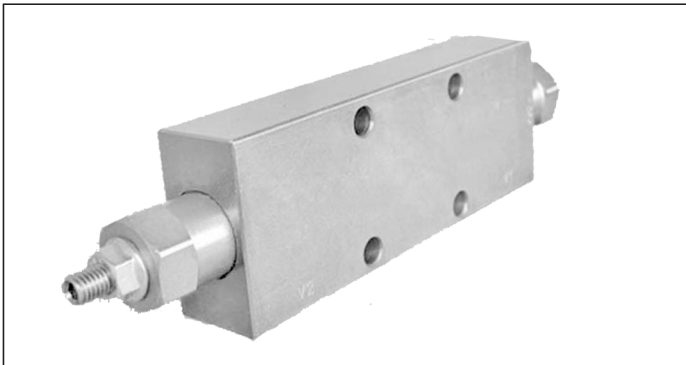

Technical data

Max. operating pressure	410 bar (5945 psi)
Max. flow	60 l/min. (16 gpm)
Weight	see "Dimensions"
Manifold material	Zinc plated steel
Flange seal kit ¹⁾	E00000000000014 (R930005947)
Fluid	Mineral oil (HL, HLP) according DIN 51524
Fluid temperature range	-30 °C to 100 (-22 to 212 °F)
Viscosity range	5 to 800 mm ² /s (cSt)
Recommended degree of fluid contamination	Class 19/17/14 according to ISO 4406
MTTFd	150 years see data sheet 18350-51
Other technical data	see data sheet 18350-50
Relief setting: at least 1.3 times the highest expected load.	

Note: for applications outside these parameters, please consult us.

¹⁾ Seals for 10 valves.

Description

It provides static and dynamic control of load by regulating the flow IN and OUT of the actuator, through ports C1 and C2. This valve module includes 2 sections, each one composed by a check and a relief valve pilot assisted by pressure in the opposite line: the check section allows free flow into the actuator, then holds the load against reverse movement; with pilot pressure applied at the line across, the pressure setting of the relief is reduced in proportion to the stated ratio until opening and allowing controlled reverse flow. Back-pressure at V1 or V2 is additive to the pressure setting in all functions. For better safety and compact assembly, the C1 and C2 ports are gasket mounted directly on the actuator.

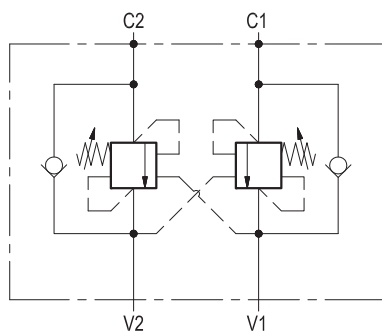

Characteristic curve

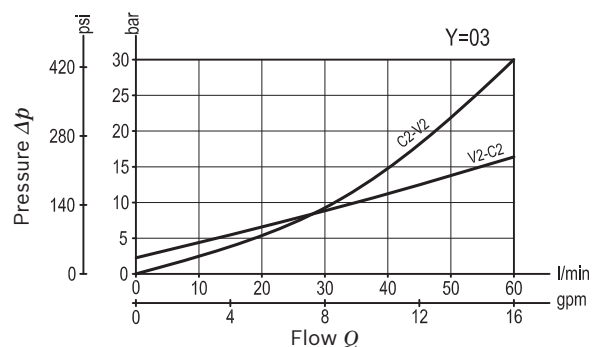

Ordering code

08.48.12	X	Y	Z
-----------------	----------	----------	----------

Dual counterbalance

Pilot ratio

03 4.2:1

85 11:1

Port sizes	V1 - V2	C1 - C2
02	G 3/8	∅ 9 (0.35)
03	G 1/2	∅ 9 (0.35)

		SPRINGS		
		Adj. pressure range bar (psi)	Pres. increase bar/turn (psi/turn)	Std. setting Q=5 (l/min) bar (psi)
20	for X=03	60-210 (870-3000)	63 (914)	200 (2900)
	for X=85	180-250 (2610-3600)	162 (2349)	200 (2900)
35	for X=03	180-350 (2610-5000)	138 (2001)	350 (5000)

Pressure setting up to 410 bar: code on request.

Tamper resistant cap code ordering code 11.04.23.002
Mat. no. R930000752



Preferred types

Type	Material number
084812030220000	R930006792
084812030235000	R930006446
084812030320000	R930006793

Type	Material number
084812030335000	R930006447
084812850220000	R930006794
084812850320000	R930006795

Dimensions

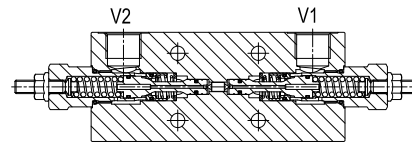
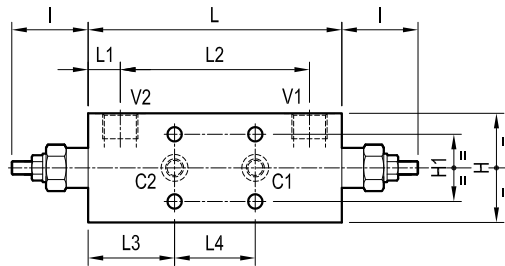
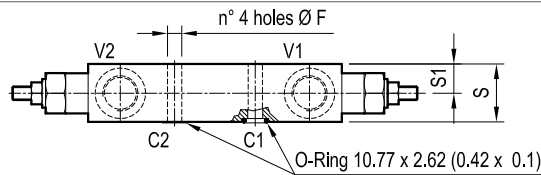

17.5 (0.69)	34.5 (1.36)	48 (1.89)	51.5 (2.03)	112.6 (4.43)	19.2 (0.76)	151 (5.95)	45.5 (1.79)	40 (1.58)	65 (2.56)	8.5 (0.34)				G 1/2	2.3 (5.1)
15 (0.59)	29.5 (1.16)	48 (1.89)	51.5 (2.03)	109.6 (4.32)	20.7 (0.82)	151 (5.95)	45.5 (1.79)	40 (1.58)	55 (2.17)	8.5 (0.34)				G 3/8	1.76 (3.88)
S1	S	L4	L3	L2	L1	L	I	H1	H	F				Y	Weight kg (lbs)

Bosch Rexroth Oil Control S.p.A.

Via Leonardo da Vinci 5
P.O. Box no. 5
41015 Nonantola - Modena, Italy
Tel. +39 059 887 611
Fax +39 059 547 848
compact-hydraulics-pib@boschrexroth.com
www.boschrexroth.com/compacthydraulics

© This document, as well as the data, specifications and other information set forth in it, are the exclusive property of Bosch Rexroth Oil Control S.p.a.. It may not be reproduced or given to third parties without its consent. The data specified above only serve to describe the product. No statements concerning a certain condition or suitability for a certain application can be derived from our information. The information given does not release the user from the obligation of own judgment and verification. It must be remembered that our products are subject to a natural process of wear and aging. Subject to change.