

**RELIEF, DIRECT ACTING GUIDED POPPET TYPE
 COMMON CAVITY**

VMD1.020

SIZE 08

0T.M1.01 - X - 99 - Z

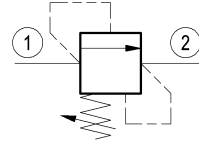
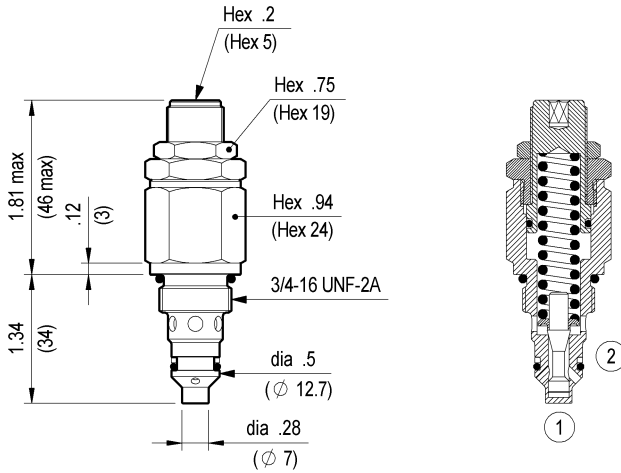

TECHNICAL DATA

Max. pressure: 5000 psi (350 bar)

Max. flow: 7 gpm (25 l/min)

Cavity : CA-08A-2N (see page CT.A.001.U)

Line bodies : see page MN1.A...

External seal kit : see page A11.011

Installation torque : 30-33 ft-lb (40-45 Nm)

Weight: 0.318 lbs (0.144 Kg)

Inches
(mm)

Flow is blocked from 1 to 2 until pressure increases to meet the selected valve setting, lifting the poppet from its seat and allowing relief flow through port 2 to tank. Pressure at port 2 is additive to the relief setting of the valve. The unique Oil Control poppet design provides enhanced stability at all flows and pressures.

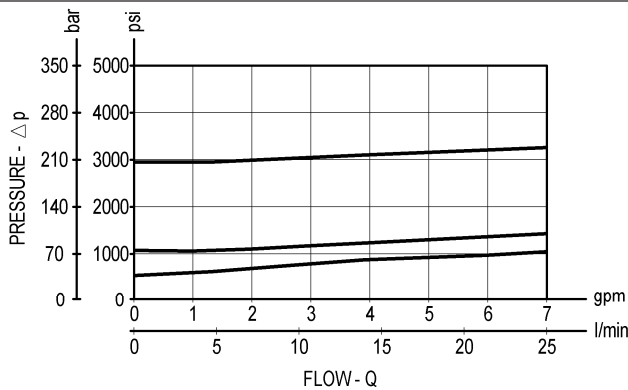

X

ADJUSTMENTS

03

Leakproof hex. socket screw

SPRINGS

Z	Adj. press. range psi (bar)	Press. increase psi / turn (bar/turn)	Standard setting psi (bar) (Q=5 l/min)		
10	350-1750 (25-120)	239 (16.5)	1450 (100)		
20	580-2900 (40-200)	384 (26.5)	2600 (180)		
35	2900-5000 (200-350)	740 (51)	5000 (350)		