

Insert type Relief, direct acting and anti-cavitation function

Special cavity, 808

VMA1.060

0T.M4.07 - X - 99 - Z - W



Dimensions

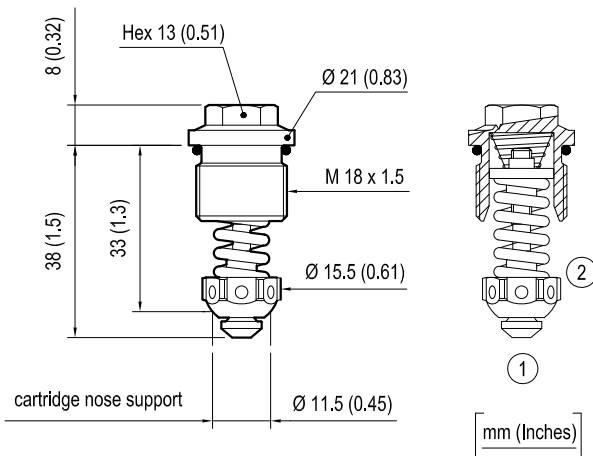

Description

Flow is free from 1 to 2 until pressure increases to meet the selected valve setting, allowing relief flow through port 1 to tank. This valve combine the typical function of shock relief valve (direct acting) and anticavitation function through the check valve. The direct action and the specific design allow a very fast opening and closing.

Note: to obtain a good leak proof performance coin the cavity seat using a loose valve seat (P/N OF.S0.036) as a coining tool.

Impact energy: 5 ± 2 Nm.

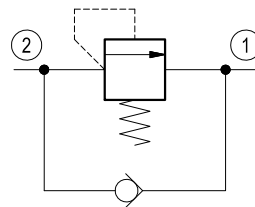

Performance

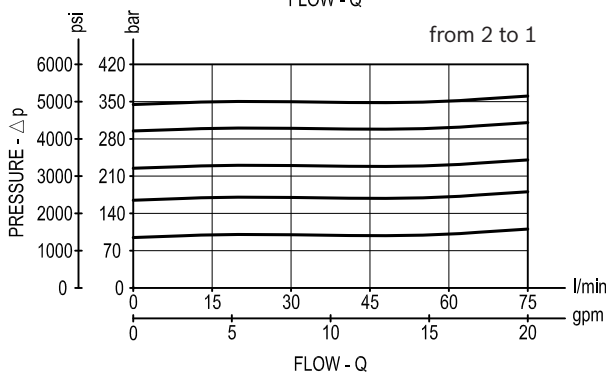
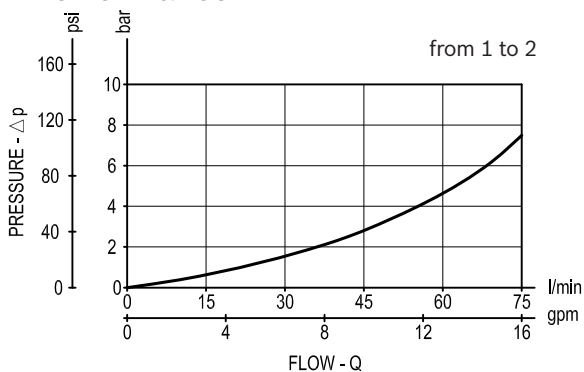

Technical data

Max. operating pressure	bar (psi)	380 (5500)
Max. flow	l/min. (gpm)	75 (20)
Max. internal leakage (*)	drops/min.	30
Fluid temperature range	°C (°F)	-30 to 100 (-22 to 212)
Installation torque	Nm (ft-lbs)	30-35 (22-26)
Weight	kg (lbs)	0.05 (0.11)
Special cavity		808
		see data sheet RE 18325-75
Seal kit (**)	code	RG0730020000100
	material no.	R931002406
Fluids		Mineral-based or synthetics with lubricating properties at viscosities of 10 to 500 mm ² /s (cSt)
Filtration		Nominal value max. 10µm (NAS 8) ISO 4406 19/17/14
Installation		No restrictions
Other Technical Data		See data sheet RE 18350-50

(*) at 80% of pressure setting

(**) Only external seals for 10 valves

Ordering code

OT.M4.07	X	99	Z	W	*
----------	---	----	---	---	---

Insert type - Relief, direct acting and anti-cavitation function

Adjustments

= 00 Fixed setting

Special cavity, 808

Series O/A to L
unchanged performances and dimensions

SPRINGS	
Adj. pressure range bar (psi)	
20-100 (290-1500)	= 05
100-170 (1500-2500)	= 10
170-230 (2500-3300)	= 20
230-300 (3300-4400)	= 30
300-380 (4400-5500)	= 35

Std. SETTING bar (psi) Q=5 l/min (1.3 gpm)

	for Z=05	for Z=10	for Z=20	for Z=30	for Z=35
= 01	20 (290)				
= 02	30 (440)	110 (1600)	180 (2610)	240 (3480)	310 (4500)
= 03	40 (580)	120 (1750)	190 (2760)	250 (3630)	320 (4640)
= 04	50 (730)	130 (1890)	200 (2900)	260 (3770)	330 (4790)
= 05	60 (870)	140 (2030)	210 (3050)	270 (3920)	340 (4930)
= 06	70 (1020)	150 (2180)	220 (3190)	280 (4060)	350 (5080)
= 07	80 (1160)	160 (2320)	230 (3340)	290 (4210)	360 (5220)
= 08	90 (1300)	170 (2470)		300 (4350)	370 (5370)
= 09	100 (1450)				380 (5510)

Type	Material number
OTM407009905010	R931002169
OTM407009905020	R931002168
OTM407009905030	R931002170
OTM407009905040	R931002171
OTM407009905050	R931002172
OTM407009905060	R931002173
OTM407009905070	R931002174
OTM407009905080	R931002175
OTM407009905090	R931002176
OTM407009910020	R931002077
OTM407009910030	R931002177
OTM407009910040	R931002080
OTM407009910050	R931002179
OTM407009910060	R931002180
OTM407009910070	R931002181
OTM407009910080	R931002183
OTM407009920020	R931002204
OTM407009920030	R931002205
OTM407009920040	R931002206

Type	Material number
OTM407009920050	R931002207
OTM407009920060	R931002208
OTM407009920070	R931002209
OTM407009930020	R931002210
OTM407009930030	R931002211
OTM407009930040	R931002212
OTM407009930050	R931001966
OTM407009930060	R931002213
OTM407009930070	R931001967
OTM407009930080	R931002214
OTM407009935020	R931002215
OTM407009935030	R931001427
OTM407009935040	R931001968
OTM407009935050	R931001969
OTM407009935060	R931002216
OTM407009935070	R931002217
OTM407009935080	R931001970
OTM407009935090	R931002218