

Pressure Reducing Valve Spool Type, Pilot-Operated SAE-8 Cartridge – 350 bar DR08P-01

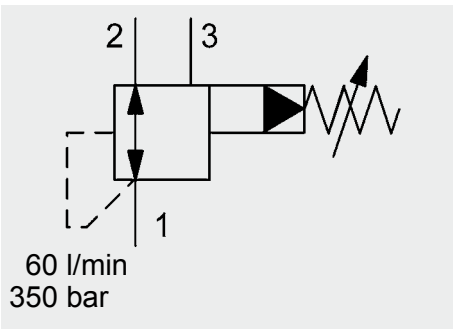

FUNCTION

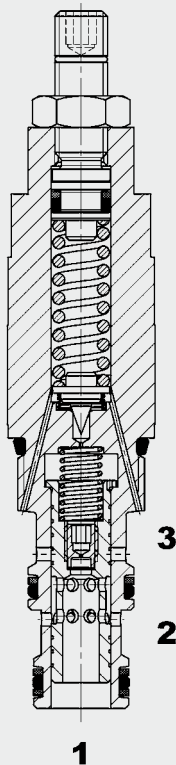

The DR08P is a pilot operated, spring-loaded, spool type pressure reducing valve. It maintains a constant outlet pressure at port 1 regardless of pressure variations at the inlet port 2.

If the pressure across port 1 rises and exceeds the pre-set value, the pilot-stage opens and oil flows from behind the main spool to the tank port 3. The resulting pressure differential causes the main spool to move against the reset-spring and allows oil to flow from port 2 to port 1. This continues until the system pressure is equal to the spring tension and the valve closes again.

If the pressure at port 1 suddenly rises due to external force the valve is relieved to tank port 3 (maximum pressure relief).

Any pressure at port 3 is directly additive to the valve pressure setting.

FEATURES

- External surfaces zinc-plated and corrosion-proof
- Hardened and ground internal valve components to ensure minimal wear and extended service life
- Excellent stability throughout the entire flow range
- Low pressure drop due to CFD optimized flow path
- Screen protected metering orifice enhances safety
- Optional spring ranges up to 345 bar
- Adjustable throughout flow range
- Quick response
- Compact design

SPECIFICATIONS

Operating pressure:	max. 350 bar
Nominal flow:	max. 60 l/min
Operating pressure ranges:	up to 35 bar up to 60 bar up to 125 bar up to 230 bar up to 345 bar
Internal leakage:	< 0.5 l/min at 350 bar
Media operating temperature range:	min. -30 °C to max. +100 °C
Ambient temperature range:	min. -30 °C to max. +100 °C
Operating fluid:	Hydraulic oil to DIN 51524 Part 1 and 2
Viscosity range:	min. 7.4 mm ² /s to max. 420 mm ² /s
Filtration:	Class 21/19/16 according to ISO 4406 or cleaner
MTTF _d :	150 years (see "Conditions and instructions for valves" in brochure 5.300)
Installation:	No orientation restrictions
Material	Valve body: free-cutting steel Spool: hardened and ground steel Seals: NBR (standard) FKM (optional, media temperature range -20 °C to +120 °C) Support rings: PTFE
Cavity:	FC08-3
Weight:	0.17 kg

DIMENSIONS

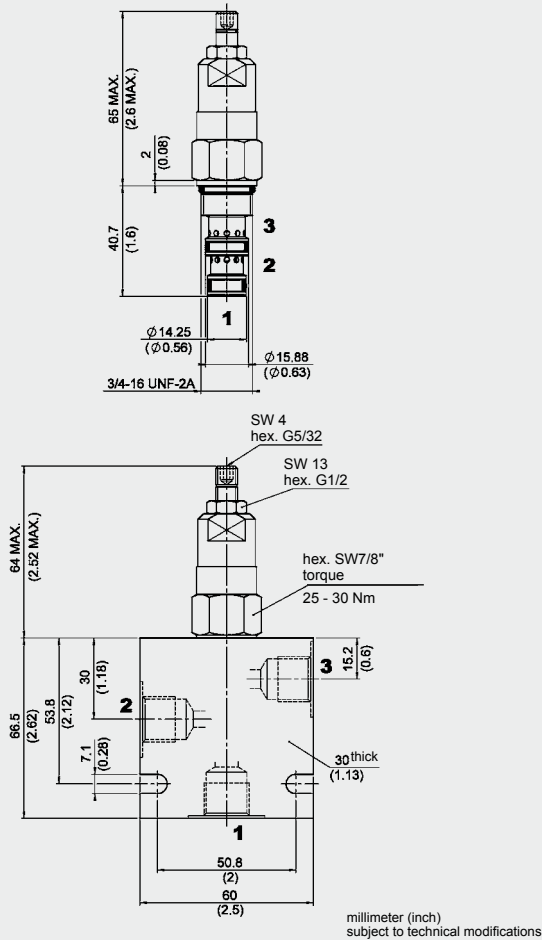

MODEL CODE

DR08P-01 - C - N - 180 V 100

Basic model _____
Pressure reducing valve UNF

Body and ports* _____
C = cartridge only
SB3 = G3/8 ports, steel body
AB3 = G3/8 ports, aluminium body

Seals _____
N = NBR
V = FKM

Setting pressure range _____
050 = 6 to 35 bar
090 = 6 to 62 bar
180 = 6 to 125 bar
330 = 6 to 228 bar
500 = 6 to 345 bar
Other pressure ranges on request

Adjustment option _____
V = Allen head (HEX 5/32")
H = Knob adjustment
F = Factory preset, non adjustable
K = Allen head (HEX 5/32") with protective cap

Cracking pressure setting _____
No details = no setting, spring relaxed
Pressure value = customer-specific cracking pressure on request

Standard models

Model Code	Part No.
DR08P-01-C-N-090V	3120532
DR08P-01-C-N-330V	3120534
DR08P-01-C-N-500V	3120535

*Standard in-line bodies

Code	Part No.	Material	Ports	Pressure
FH083-SB3	560922	Steel, zinc-plated	G3/8	420 bar
FH083-AB3	3011427	Aluminium, anodized	G3/8	210 bar

Seal kits

Code	Material	Part No.
FS083-N SEAL KIT	NBR	3054795
FS083-V SEAL KIT	FKM	2591059

CAVITY

FC08-3

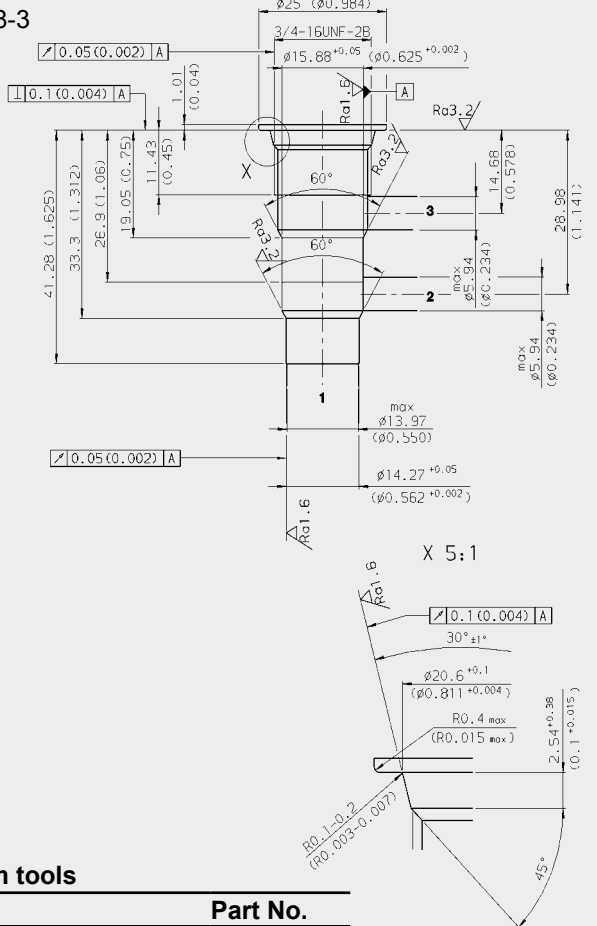

Form tools

Tool	Part No.
Rougher FC08-3	175644
Reamer FC08-3	175645

millimeter (inch) subject to technical modifications

PERFORMANCE

Measured at $v = 34 \text{ mm}^2/\text{s}$, $T_{\text{oil}} = 46 \text{ }^\circ\text{C}$

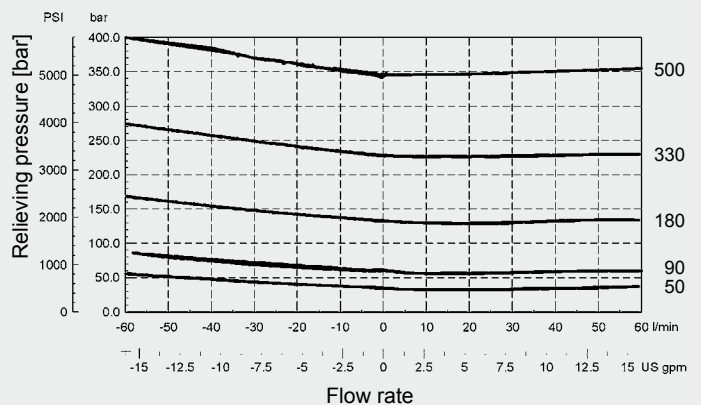

NOTE

The information in this brochure relates to the operating conditions and applications described. For applications or operating conditions not described, please contact the relevant technical department. Subject to technical modifications.

HYDAC Fluidtechnik GmbH
Justus-von-Liebig-Str.
D-66280 Sulzbach/Saar
Tel: 0 68 97 /509-01
Fax: 0 68 97 /509-598
E-Mail: flutec@hydac.com