

4/3 - 4/2 Directional valve elements with proportional control and with or without LS connections

RE 18301-06/07.12
Replaces: 10.09

1/10

L8_80... (ED4-P)

Size 6
Series 00
Maximum operating pressure 310 bar [4500 psi]
Maximum flow 30 l/min [7.9 gpm]
Port connections G 3/8 - G 1/2 - SAE6 - SAE8



DVI0017

Summary

Description	Page
General specifications	1
Ordering details	2
Configuration	2
Spool variants	3
Principles of operation, cross section	3
Technical Data	4
Δp - Q_v characteristic curves	5
External Dimensions and Fittings	6
Electric connections	8
Electronic feed regulators	9

General specifications

- Valve element with direct proportional control of spool.
- Control spool operated by solenoid with removable coils.
- In the de-energized condition, the control spool is held in the central position by return springs.
- Wet pin proportional tubes for DC coils, with push rod for mechanical override; nickel plated surface.
- Manual override (push-button or screw type) available as option.
- Plug-in connectors available: EN 175301-803 (Was DIN 43650) and DT04-2P (Deutsch).

Ordering Details

L 8 _ 8 0 _ _ _ _ _ _ 0 _ _																			
Family Directional valve elements ED										Options No code = No options									
Type Size 6, proportional										0P = Push-button type manual override									
Configurations Standard = 0										0F = Screw type manual override									
With Load Sensing control = 4										_ _ = Lever type manual override ²⁾									
Coil type D15										Ports 0 = G 3/8 DIN 3852									
Spool variants ¹⁾										1 = 9/16-18 UNF 2-B (SAE6)									
4/3 operated both sides a and b; P – T closed in neutral = B2										2 = G 1/2 DIN 3852									
4/2 operated on side a only; P – T closed in neutral = B3										3 = 3/4-16 UNF 2-B (SAE8)									
4/2 operated on side b only; P – T closed in neutral = B4										Electric connections									
4/3 operated on both sides a and b; A and B to T in neutral = E2										00 = Without coils									
4/2 operated on side a only; A and B to T in neutral = E3										01** = With coils, without mating connector DIN EN 175301-803									
4/2 operated on side b only; A and B to T in neutral = E4										03 = With coils, with bi-directional diode, without mating connector vertical Amp-Junior									
Flow pattern										07 = With coils, with bi-directional diode, without mating connector DT04-2P									
Both meter in and out = S										Voltage supply									
Meter in = I										00 = Without coil									
Nominal flow [*]										OB = 12V DC									
10 l/min [2.64 gpm] = 2										OC = 24V DC									
20 l/min [5.28 gpm] = 4										<table border="1"> <tr> <td>07</td> <td>03</td> <td>01</td> <td>00</td> </tr> <tr> <td colspan="4">Available Connections</td> </tr> </table>		07	03	01	00	Available Connections			
07	03	01	00																
Available Connections																			
30 l/min [7.9 gpm] = 6										<p>1) The required hydraulic symbol and spool variant can be chosen by consulting page 3.</p> <p>2) Each different option for the type of manual override chosen implies a specific ordering code (refer to page 7).</p> <p>* With Δp (P > T) 10 bar [145 psi], corresponding approx. to Δp (P > A,B) 5 bar [73 psi].</p> <p>** For connectors ordering code see data sheet RE 18325-90.</p>									

Configuration

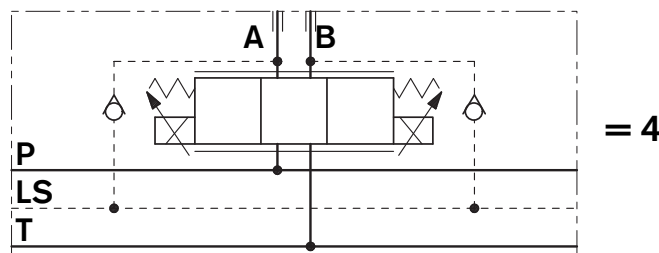
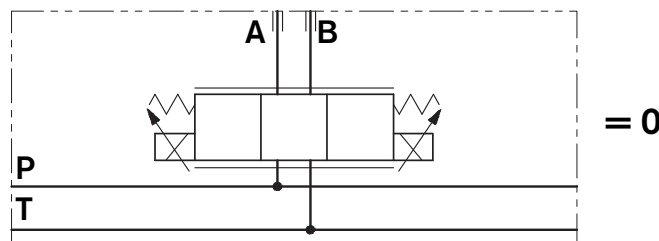

Spool variants

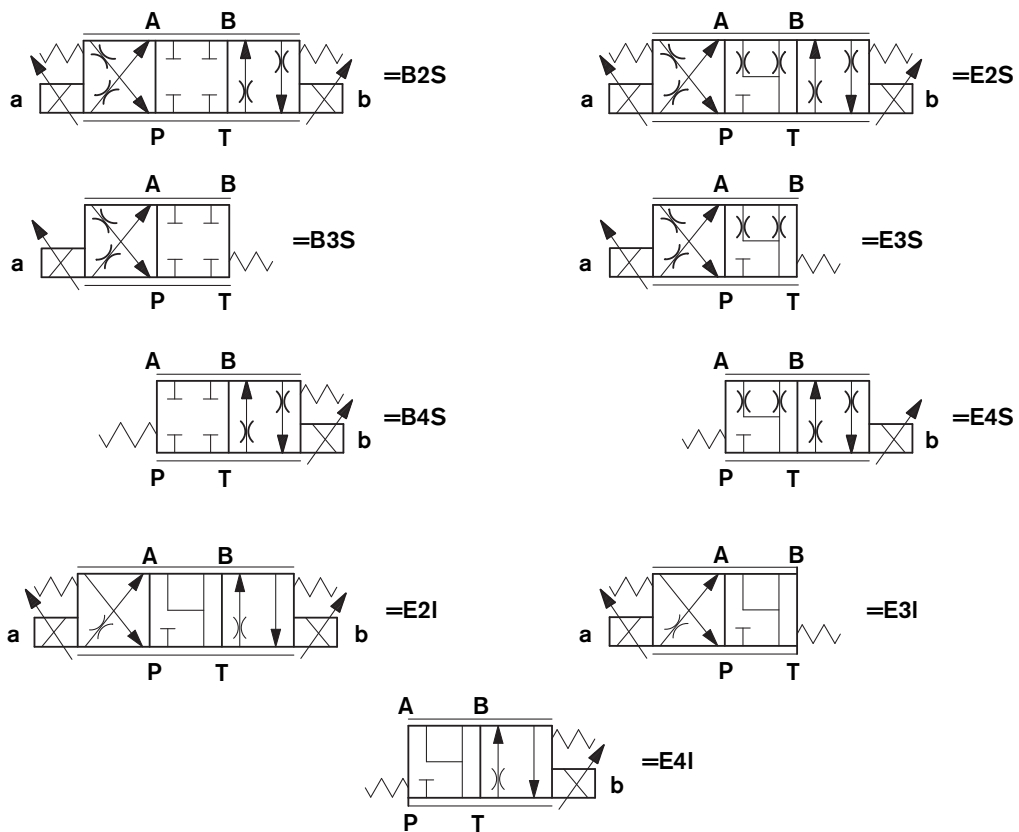

In neutral position, the valves cross section are as follows:

$E_I \geq 20\%$ of nominal cross section.

$E_S \geq 2\%$ of nominal cross section.

Principles of operation, cross section

The sandwich plate design directional valve elements L8080... are compact direct operated proportional solenoid valves which control the start, the stop, the direction and the quantity of the oil flow. These elements basically consist of a stackable housing (1) with a control spool (2), one or two solenoids (3), and one or two return springs (4).

Energized by an electronic feed regulator, each solenoid (3) displaces the control spool (2) from its neutral-central position "0" proportionally to the current received; a regulated

oil flow P to A, or P to B, is achieved. Once the solenoid is de-energized, the return spring (4) pushes the spool thrust washer (5) back against the housing and the spool returns in its neutral-central position.

Each coil (3) is fastened to the solenoid tube by a ring nut (6). A pin (7) allows to push the spool (2) in emergency conditions, when the solenoid cannot be energized, like in case of voltage shortage.

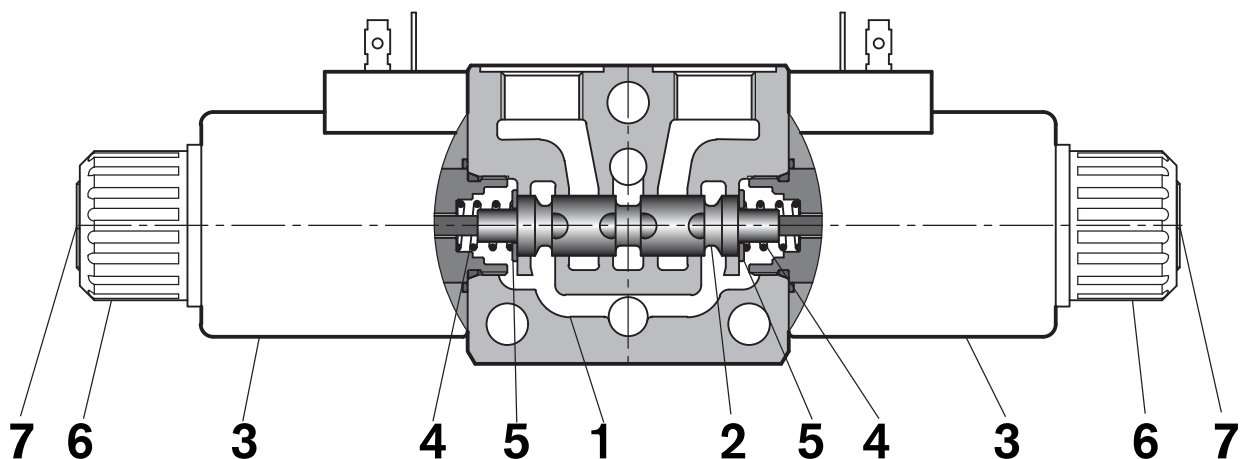

Technical Data (for applications with different specifications consult us)**General**

Valve element with 2 solenoids	kg [lbs]	2.20 [4.85]
Valve element with 1 solenoid	kg [lbs]	1.70 [3.75]
Ambient Temperature	°C [°F]	-20....+50 [-4....+122] (NBR seals)

Hydraulic

Maximum pressure at P	bar [psi]	310 [4500]
Maximum pressure at T	bar [psi]	210 [3050]
Maximum inlet flow	l/min [gpm]	30 [7.9]
Nominal flow with $\Delta P P > T = 10$ bar [145 psi]	l/min [gpm]	10, 20, 30 [2.64, 5.28, 7.9]
Hydraulic fluid General properties: it must have physical lubricating and chemical properties suitable for use in hydraulic systems such as, for example:		Mineral oil based hydraulic fluids HL (DIN 51524 part 1). Mineral oil based hydraulic fluids HLP (DIN 51524 part 2). For use of environmentally acceptable fluids (vegetable or polyglycol base) please consult us.
Fluid Temperature	°C [°F]	-20....+80 [-4....+176] (NBR seals)
Permissible degree of fluid contamination		ISO 4572: $\beta_x \geq 75$ X=10...12 ISO 4406: class 19/17/14 NAS 1638: class 8
Viscosity range	mm ² /s	20....380 (optimal 30....46)

Electrical

Voltage type	PWM	120 Hz							
Voltage tolerance (nominal voltage)	%	-10 +10							
Duty		Continuous, with ambient temperature $\leq 50^\circ\text{C}$ [122°F]							
Coil wire temperature not to be exceeded	°C [°F]	150 [302]							
Insulation class		H							
Compliance with		Low Voltage Directive LVD 73/23/EC (2006/95/EC), 2004/108/EC							
Coil weight	kg [lbs]	0.335 [0.739]							
Voltage	V	12	24						
Nominal 100% Current	A	1.76	0.88						
Resistance (nominal at 20°C [68°F])	- Cold value at 20°C	Ω	4	16					
	- Max. hot value	Ω	6.1	24.4					

	Voltage (V)	Connector type	Coil description	Marking	Coil Mat no.
=OB 01	12 DC	EN 175301-803 (Ex. DIN 43650)	D15 01	12 DC	R933000092
=OB 03	12 DC	AMP JUNIOR	D1530	12 DC	R933002877
=OB 07	12 DC	DEUTSCH DT 04-2P	D15 07	12 DC	R933000094
=OC 01	24 DC	EN 175301-803 (Ex. DIN 43650)	D15 01	24 DC	R933000093
=OC 03	24 DC	AMP JUNIOR	D1530	24 DC	R933003515
=OC 07	24 DC	DEUTSCH DT 04-2P	D15 07	24 DC	R933002798

Characteristic curves

Measured with hydraulic fluid ISO-VG32 at $45^{\circ} \pm 5^{\circ} \text{ C}$ [$113^{\circ} \pm 9^{\circ} \text{ F}$]; ambient temperature 20° C [68° F].

Ordering code 2: 10 l/min [2.64 gpm] with $\Delta p = 10 \text{ bar}$ [145 psi].

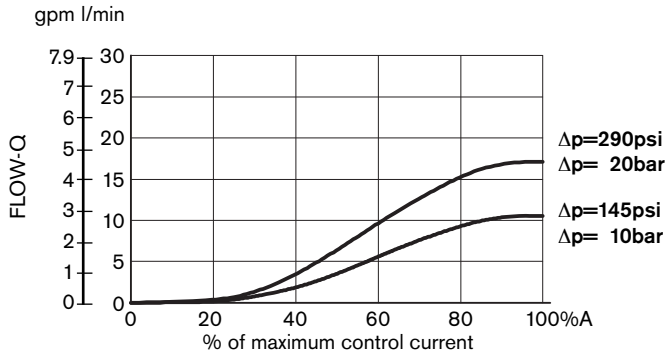

Ordering code 4: 20 l/min [5.28 gpm] with $\Delta p = 10 \text{ bar}$ [145 psi].

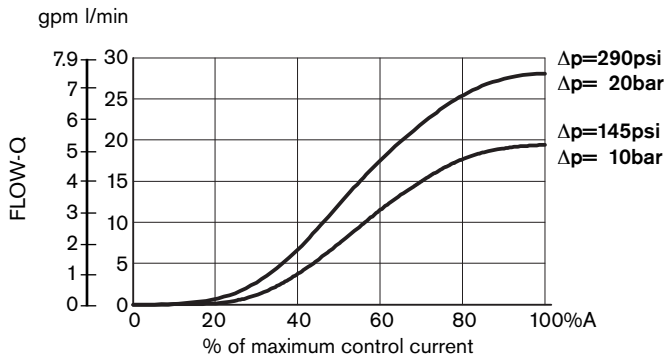

Ordering code 6: 30 l/min [7.92 gpm] with $\Delta p = 10 \text{ bar}$ [145 psi].

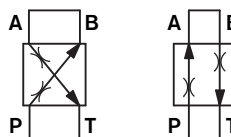
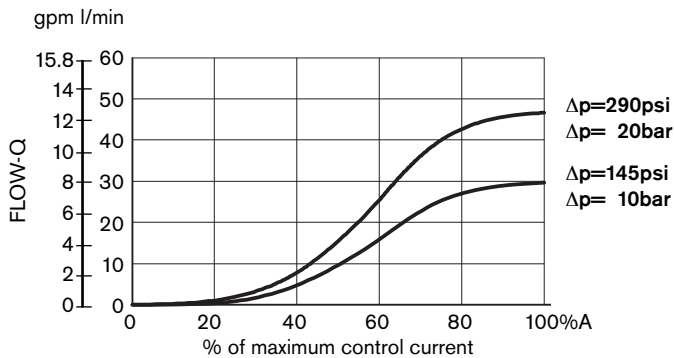

External Dimensions and Fittings

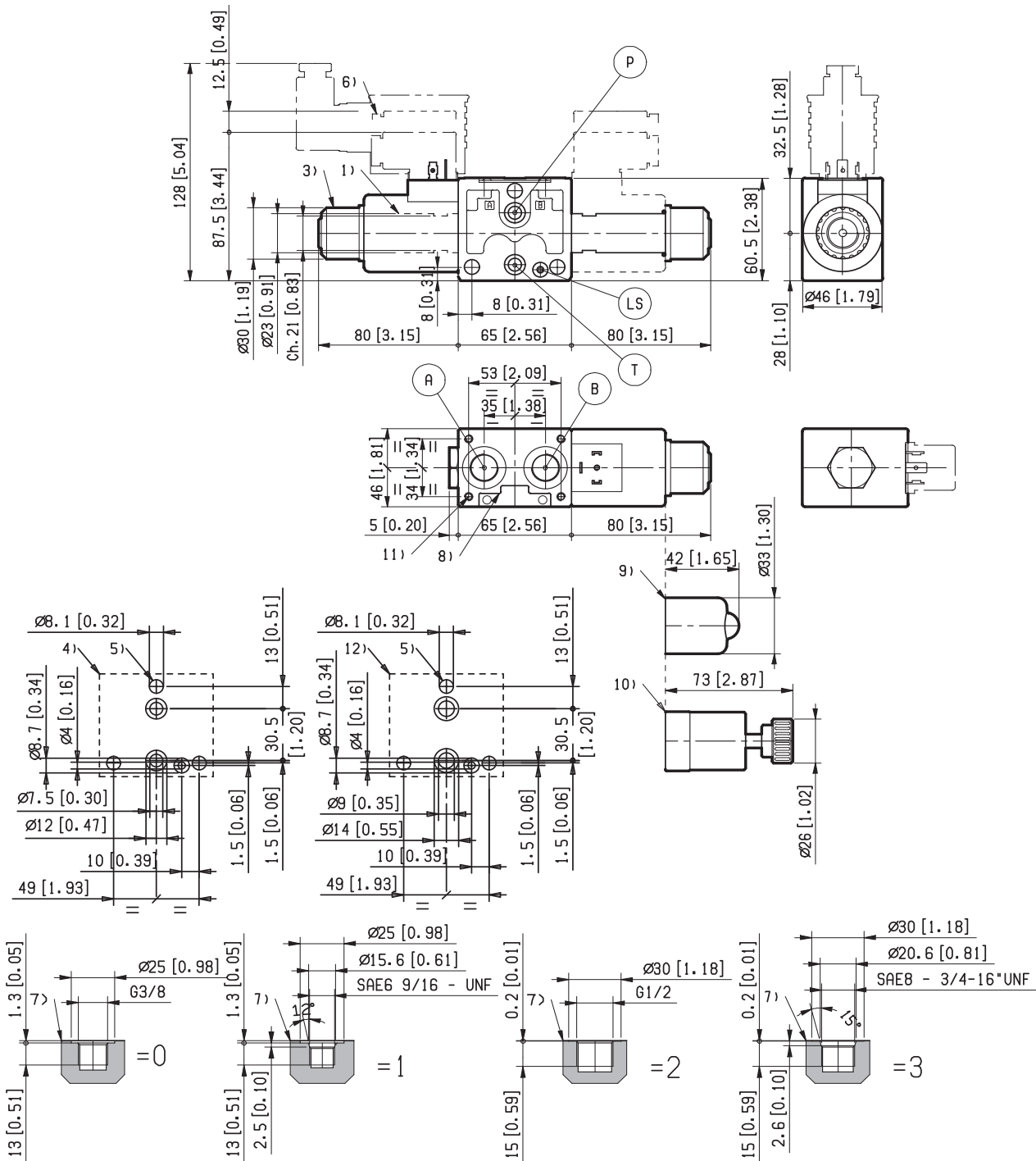

- 1 Solenoid tube \varnothing 23 mm [0.9 inch].
- 3 Ring nut for coil locking (\varnothing 30 mm); torque 6 – 7 Nm [4.4 – 5.2 ft-lb].
- 4 Flange specifications for coupling to ED intermediate elements with ports G 3/8 and SAE 6.
- 5 For tie rod and tightening torque information see data sheet RE 18301-90.
- 6 Clearance needed for connector removal.
- 7 A and B ports.
- 8 Identification label.
- 9 Optional push-button manual override, EP type, for spool opening: it is pressure stuck to the ring nut for coil locking. Mat no. R933003289.
- 10 Optional screw type manual override, EF type, for spool opening: it is screwed (torque 6-7 [4.4-5.2 ft-lb]) to the tube as replacement of the coil ring nut. Mat no. R933003116.
- 11 Four threaded holes M5 for fitting a secondary flangeable element (only for elements with ports G 3/8 and SAE 6). Bolts M5 with recommended strength class DIN 8.8: torque 5 – 6 Nm [3.6-4.4 ft-lb].
- 12 Flange specifications for coupling to ED intermediate elements with ports G 1/2 and SAE 8.

Electric connections

Protection class: IP 65 when connector with seal is properly screwed down.

=01

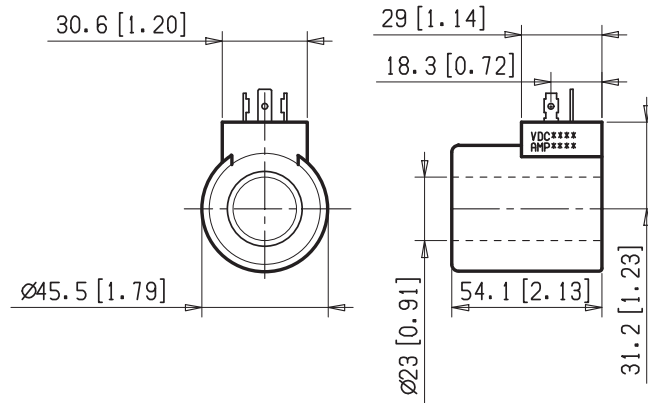

Protection class: IP 65 with female connector properly fitted (see drawing).

=03

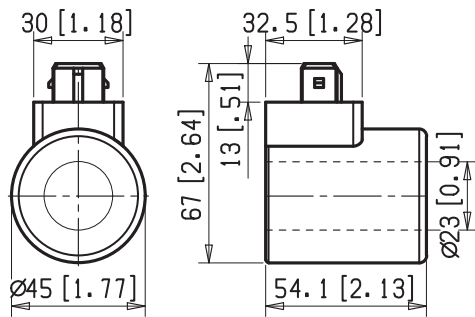

Protection class: IP 69 K with female connector properly fitted (see drawing).

=07

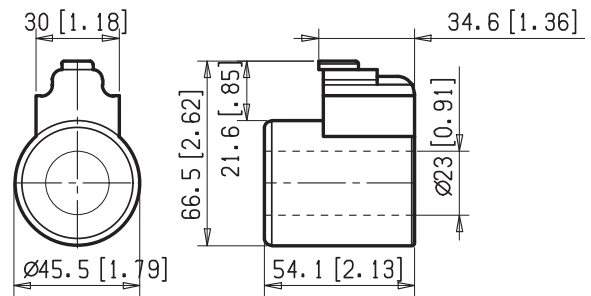

Electronic feed regulator

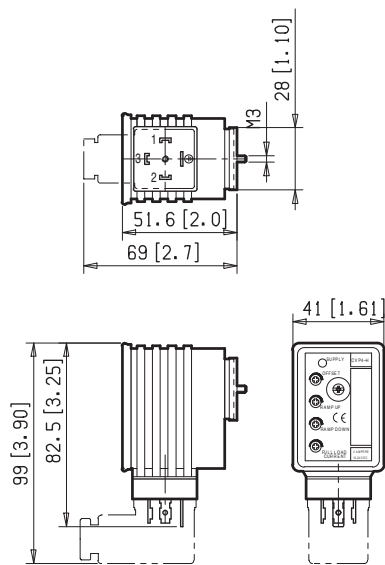

Supply: yellow LED, lit up with power ON.

Off Set: minimum current adjustment. Adjust solenoid current so that the desired minimum value is obtained. Clockwise rotation increases current.

Ramp up: Ramping up time adjustment.

Ramp down: Ramping down time adjustment.

For longer ramping times, turn potentiometers clockwise; for shorter ramping times, turn the potentiometers counter-clockwise.

Full load current: Maximum current adjustment. Adjust solenoid current so that the desired maximum value is obtained (up to 2A). Clockwise rotation increases current.

Frequency adjustment: it is possible to set the PWM frequency obtaining the desired control sensitivity. After removing the external plastic cover, turn the adjusting screw; clockwise rotation increases frequency from 100 to 500 Hz.

Regulator ordering code	R933003290
Supply voltage	12-30 VDC
Control Signal	0-10 VDC
Max. output current	2 A
Minimum output current	0...0.6 A
Ramp adjustment up/down	0.1 ...10 s
PWM Frequency adjustment (pre-set 120 Hz)	100...500 Hz
Ambient operating temperature	-10...+60 °C [14...+140 °F]
Weight	0.12Kg [26.4 lbs]
Electromagnetic compatibility	EN50081-1/2EN61000-4-2/3/4/5/6
Protection class with connector and seal correctly fitted and properly screwed down.	IP 65 (DIN40050 part 9)
Potentiometer resistance	5...10 k Ω

