

# End of stroke normally closed

A-VMS-10-NC

FC 10 NC

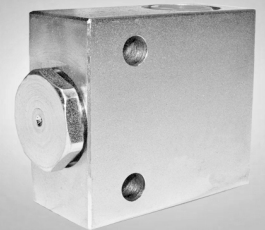

## Description

This pushbutton valve allows oil passage in a hydraulic circuit (normally closed valve); once the slider is set into action oil flow is free from B to A and it can be used as end of stroke valve where the flow is directly connected to the tank.

Connect A directly to the tank and B as for necessity; mounting scheme can vary according to the use.

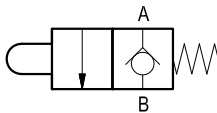

## Performance

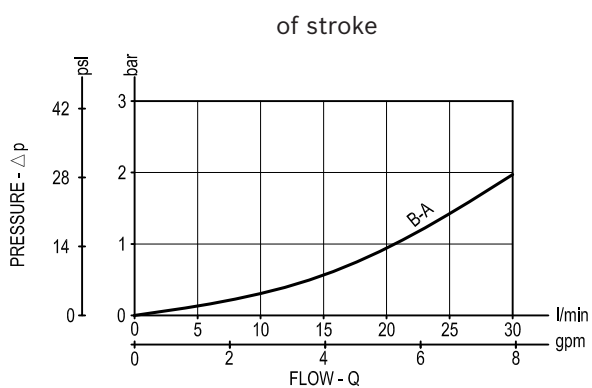

## Technical data

### Hydraulic

Max. operating pressure	bar (psi)	250 (3600)
Max. flow	l/min (gpm)	30 (8)

Relief setting: at least 1.3 times the highest expected load.

### General

Manifold material		Steel
Weight	kg (lbs)	0.8 (1.76)
Fluid temperature range	°C (°F)	between -30 (-22) and +100 (212)
Other technical data		see data sheet RE 18350-50

Note: for applications outside these parameters, please consult us.

Dimensions

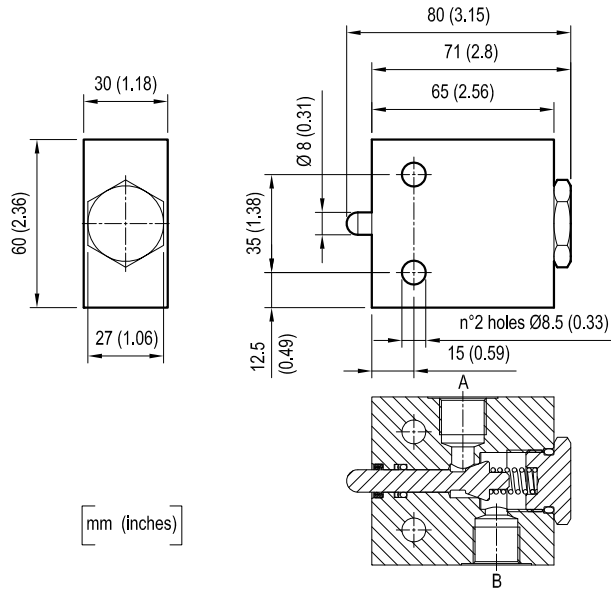

Spring weight - N	
End stroke	Of stroke
80	240

Ordering code

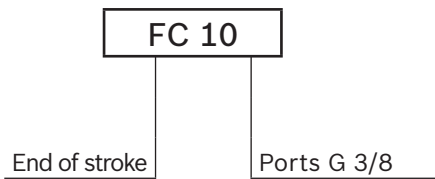

Type	Material number
FC 10	R932500192

Type	Material number