

**General Description**

Series FM double flow control valves permit free flow from the directional valve to the actuator and adjustable independent flow regulation in each return line from the actuator (meter-out). The FM2 and FM3 have a seal plate and can be inverted for meter-in applications (see installation drawing for flow direction).

**Features**

- FM style flow control valves can be provided in either single or double configurations.
- The flow controls may be positioned in 'A' port, 'B' port, both 'A' and 'B' ports or 'P' port.
- Valve bodies are manufactured from steel providing extra strength and durability for longer life. Internal hardened steel components also provide longer life.
- Two step needles provide fine adjustment for the first few turns and course adjustment for the last few turns. Standard and fine adjustment needles available.
- Large bypass checks allow high flow at a low pressure drop.
- Valve is reversible (invert 180°) for meter-in or meter-out applications (FM2 and FM3 only).
- Adjustment options include Allen hex or hand knob.

**Performance Curves**

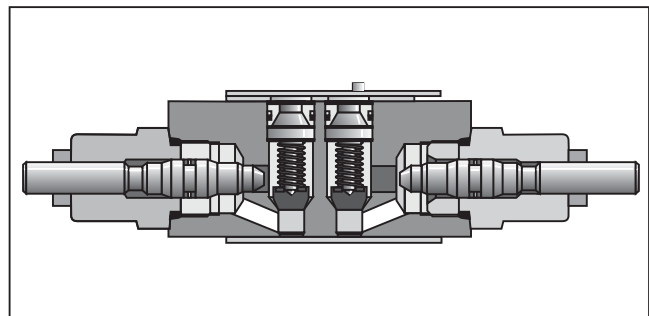
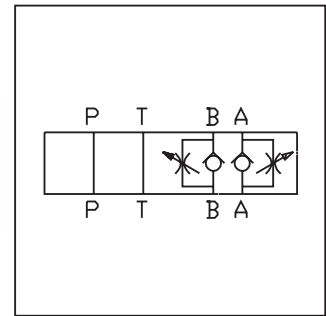
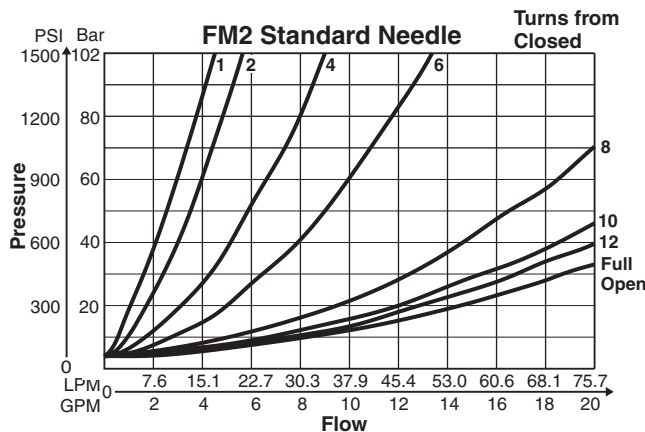
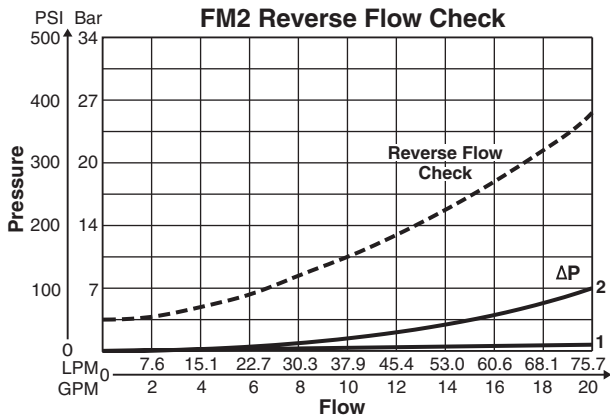

**Specifications**

	FM2	FM3	FM6
<b>Mounting Pattern</b>	NFPA D03, CETOP 3, NG 6	NFPA D05, CETOP 5, NG 10	NFPA D08, CETOP 8, NG 25
<b>Maximum Pressure</b>	345 Bar (5000 PSI)	345 Bar (5000 PSI)	205 Bar (3000 PSI)
<b>Maximum Flow</b>	76 LPM (20 GPM)	113 LPM (30 GPM)	341 LPM (90 GPM)
<b>Cracking Pressure</b>	0.3 Bar (5 PSI)	0.3 Bar (5 PSI)	0.3 Bar (5 PSI)

**Pressure Drop Reference Chart**

	P	A	B	T
PP	*	2	2	1
DD	1	*	*	1
AA	1	*	1	1
BB	1	1	*	1

\* See specific flow vs. turns

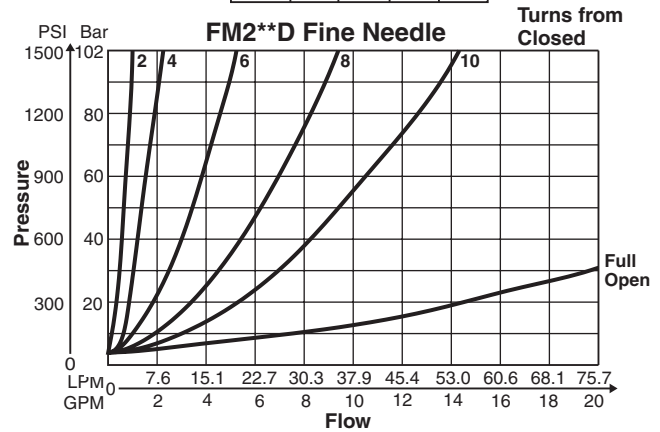

Curves were generated using 100 SSU hydraulic oil @49°C (120°F). For any other viscosity, pressure drop will change as per chart.

Viscosity Correction Factor							
Viscosity (SSU)	75	150	200	250	300	350	400
Percentage of ΔP (Approx.)	93	111	119	126	132	137	141

Parker Sandwich.indd, dd

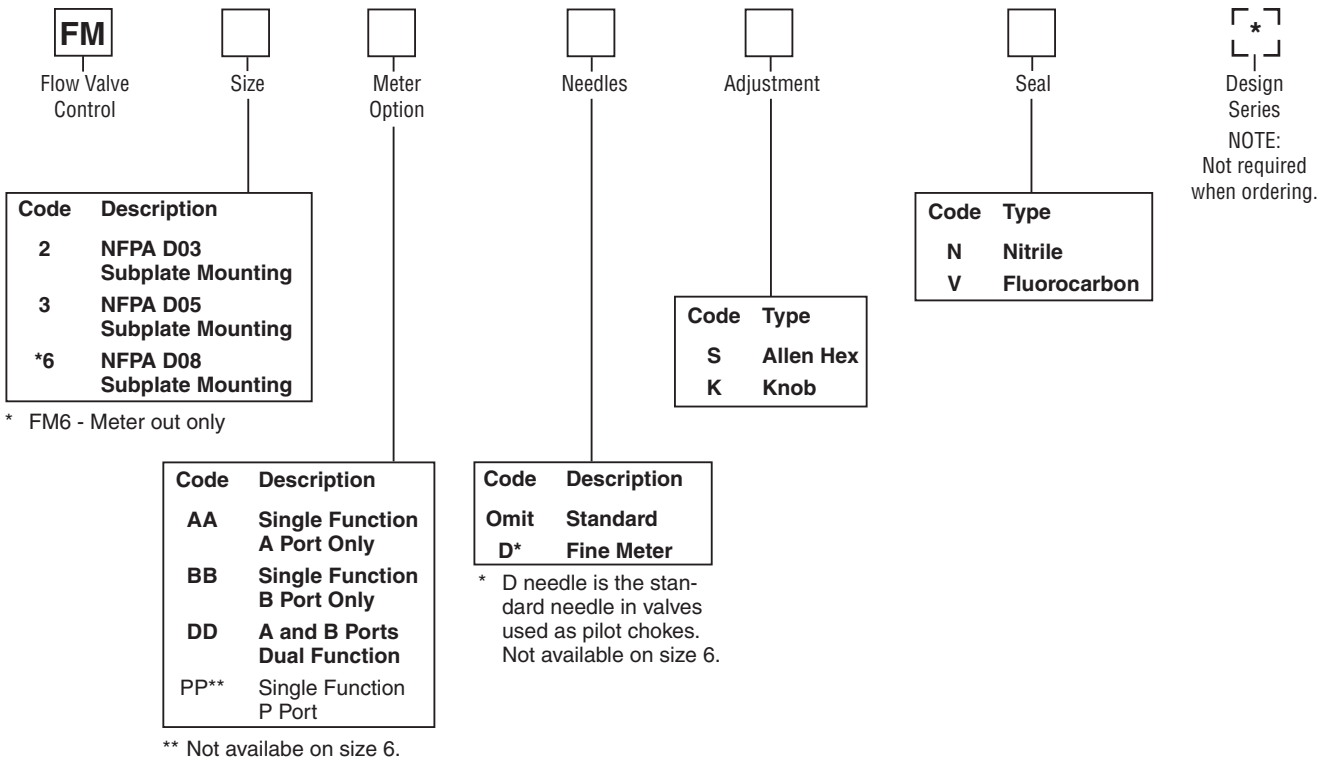

**Bold: Designates Tier I products and options.**  
**Non-Bold: Designates Tier II products and options. These products will have longer lead times.**

**Bolt Kits**

Size "2"				Size "3"			
No. of Sandwich	Sandwich & Valve Combination	Bolt Kit	Bolt Length mm (in)	No. of Sandwich	Sandwich & Valve Combination	D3W-30 D3DW & D31*W*	Bolt Length mm (in)
1	Sandwich & D1	BK243	73.2 (2.88)	1	Sandwich & D3	BK141	88.9 (3.50)
2	Sandwich & D1	BK225	111.3 (4.38)	2	Sandwich & D3	BK142	139.7 (5.50)
3	Sandwich & D1	BK244	152.4 (6.00)	3	Sandwich & D3	BK143	190.5 (7.50)
4	Sandwich & D1	BK245	190.5 (7.50)				

\* D31VW with internal pilot and internal drain only.

Size "6"			
No. of Sandwich	Sadnwich & Valve Combination	Bolt Kit	Bolt Length mm (in)
1	Sandwich & D6	BK121	133.4 (5.25)
2	Sandwich & D6	BK122	203.2 (8.00)
3	Sandwich & D6	BK123	273.1 (10.75)
4	Sandwich & D6	BK124	342.9 (13.5)

**Unit Weight:**

- FM2 1.7 kg (3.8 lbs.)
- FM3 2.4 kg (5.2 lbs.)
- FM6 7.9 kg (17.5 lbs.)

Bolt Kits must be ordered separately.

**Schematics**

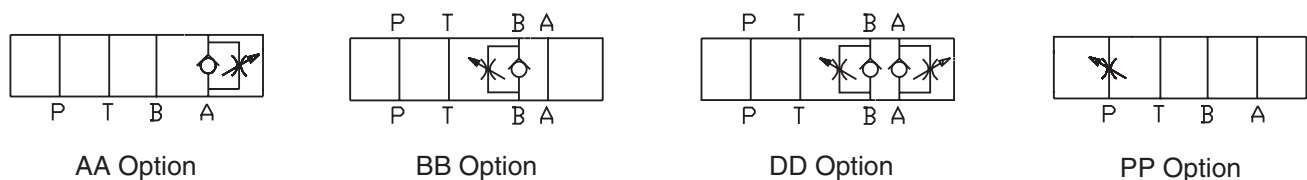

**B**

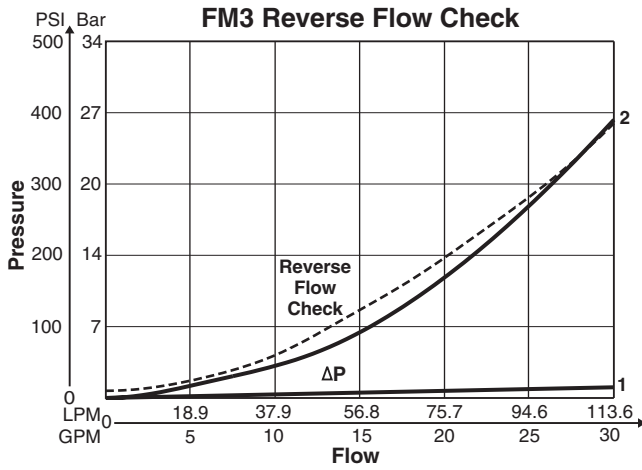

**Pressure Drop Reference Chart**

	P	A	B	T
PP	*	2	2	1
DD	1	*	*	1
AA	1	*	1	1
BB	1	1	*	1

\* See specific flow vs. turns chart

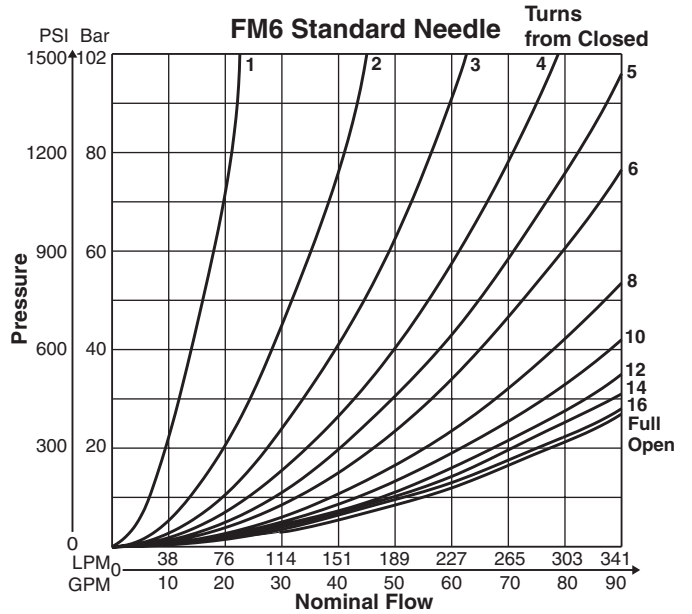
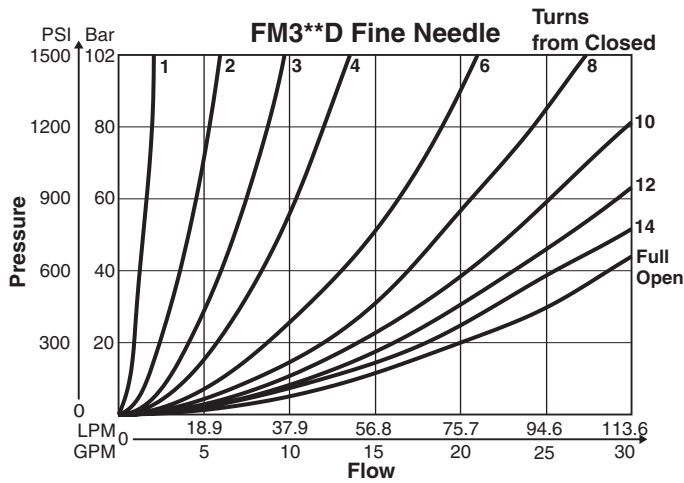
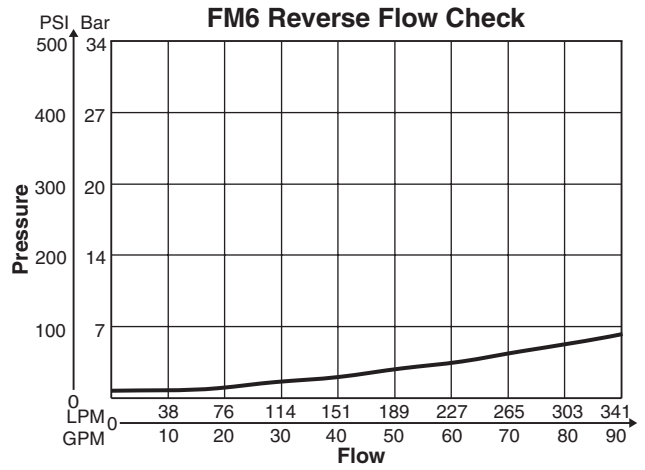
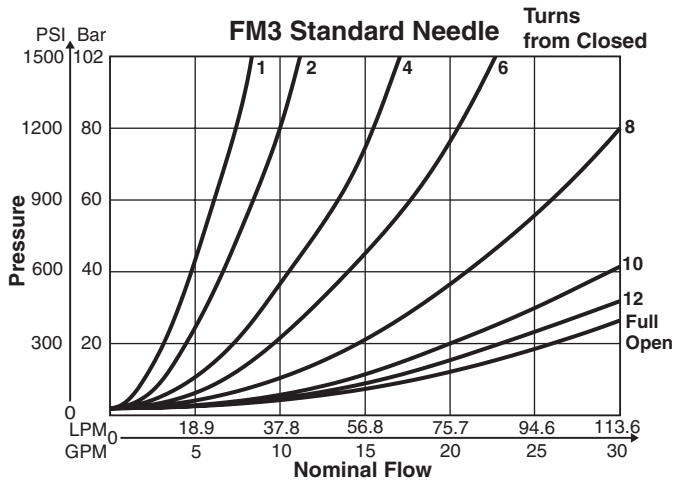

Inch equivalents for millimeter dimensions are shown in (\*\*)

**B**

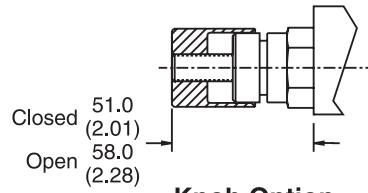

**Knob Option**

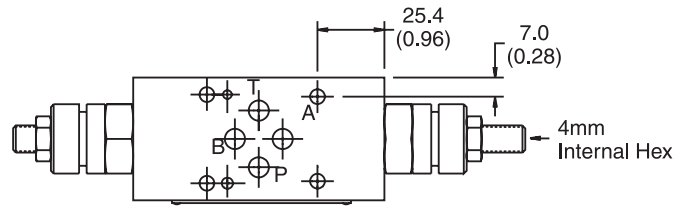

**Top View**

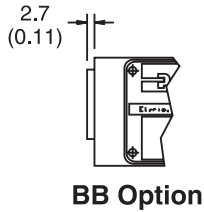

**BB Option**

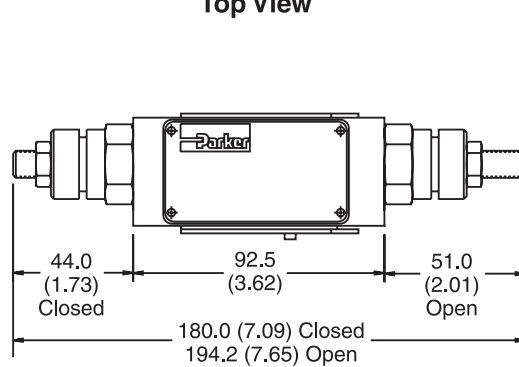

**Face View**

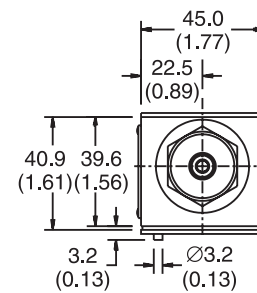

**End View**

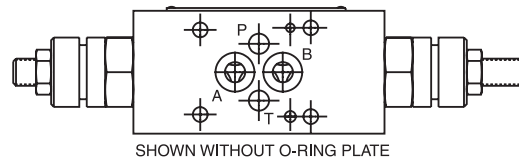

**Bottom View**

Note: For meter-in option, invert body 180°.



Inch equivalents for millimeter dimensions are shown in (\*\*)

**B**

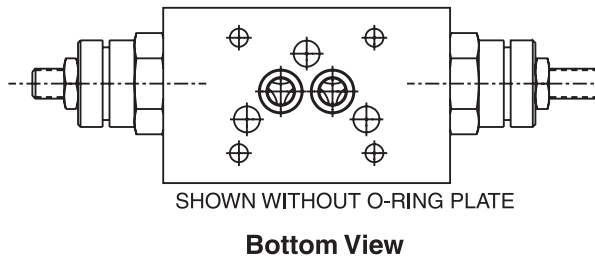
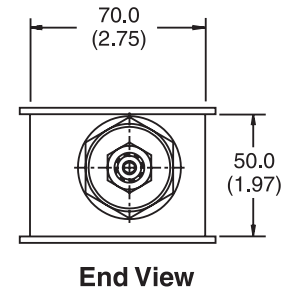
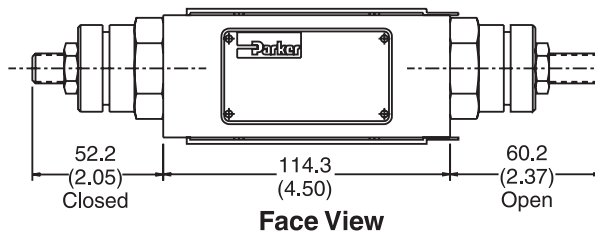
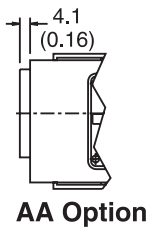
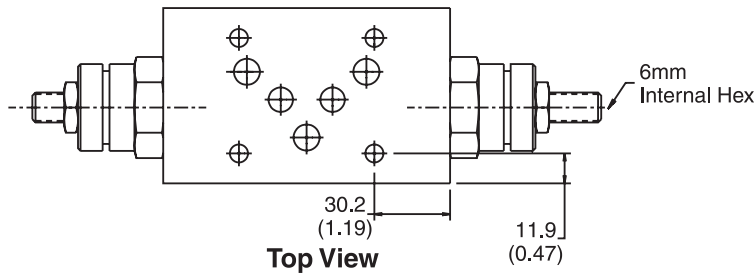
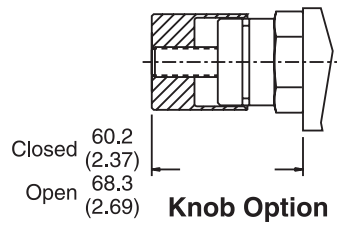

Note: For meter-in option, invert body 180°.

Inch equivalents for millimeter dimensions are shown in (\*\*)

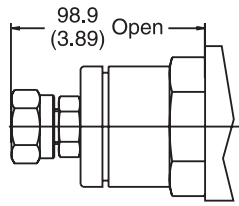

**Knob Option**

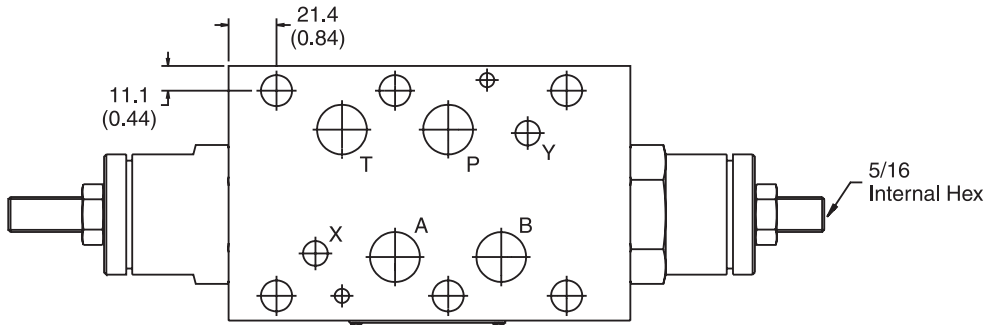

**Top View**

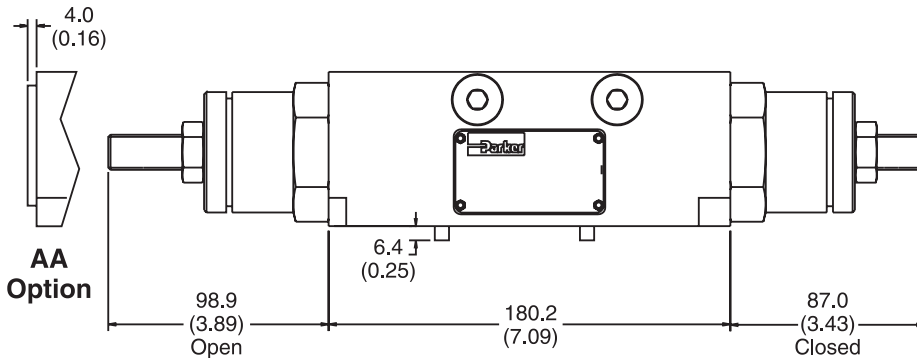

**Face View**

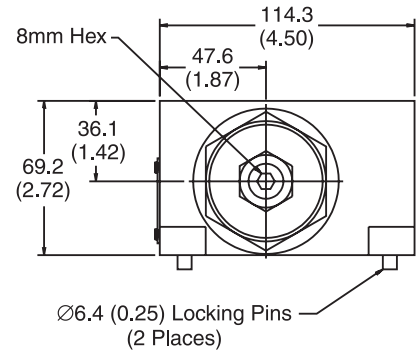

**End View**

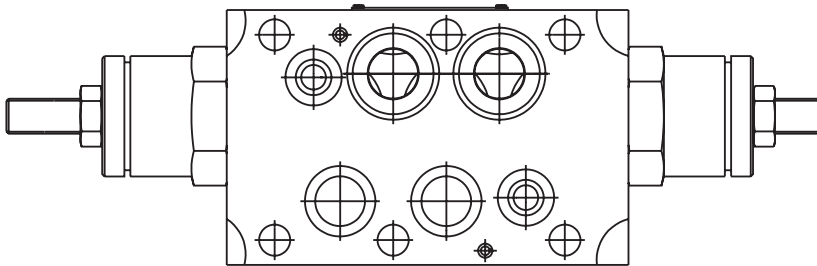

**Bottom View**



**B**