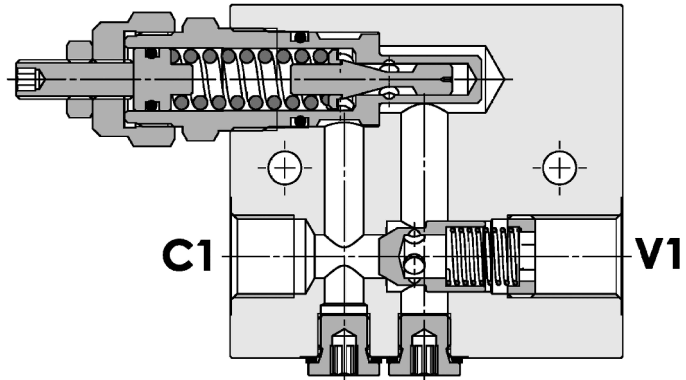
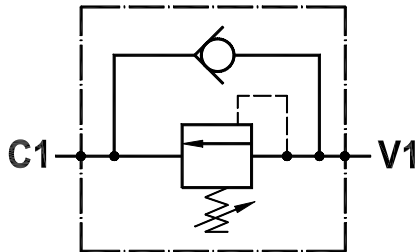

**Valvola di sequenza ad azione diretta - montaggio in linea**
Direct acting sequence valve, line mounted

Rev.02-2017/07

**SPECIFICHE TECNICHE**

Materiali: cartuccia in acciaio zincato, parti interne in acciaio trattato termicamente. Blocchetto in acciaio.

Portata: 80 l/min

Taratura max.: 320 bar

Pressione max.: 350 bar

Regolazione pressione: mediante vite o volantino (P/R)

Peso: 2,600 Kg

TECHNICAL SPECIFICATIONS

Materials: cartridge in steel zinc plated, internal parts are in hardened steel. Body is in steel.

Rated flow: 80 l/min

Max. setting: 320 bar

Max. pressure: 350 bar

Adjustment means: leakproof screw or handknob (P/R)

Weight: 2,600 Kg

DIAGRAMMA PERDITE DI CARICO - PRESSURE DROP CURVES

Viscosità olio 24 mm²/sec. (3,5 °E)
Temperatura 50 °C

Oil viscosity 24 mm²/sec. (3,5 °E)
Temperature 50 °C

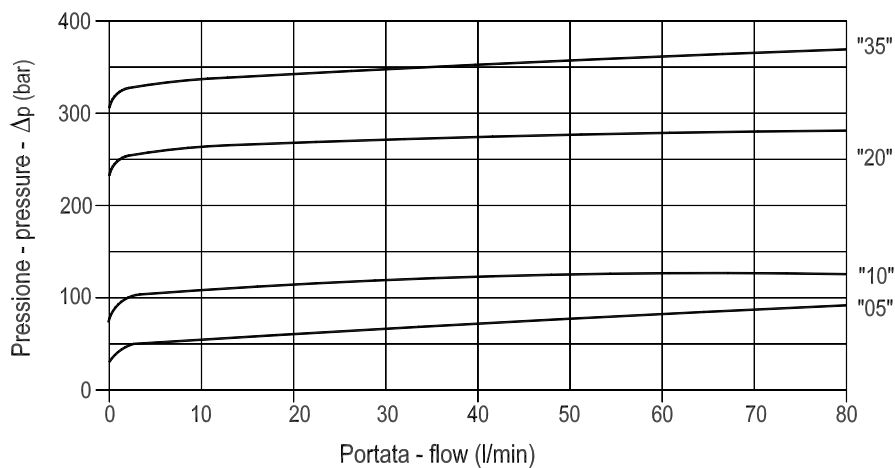



Valvola di sequenza ad azione diretta - montaggio in linea
Direct acting sequence valve, line mounted

Rev.02-2017/07

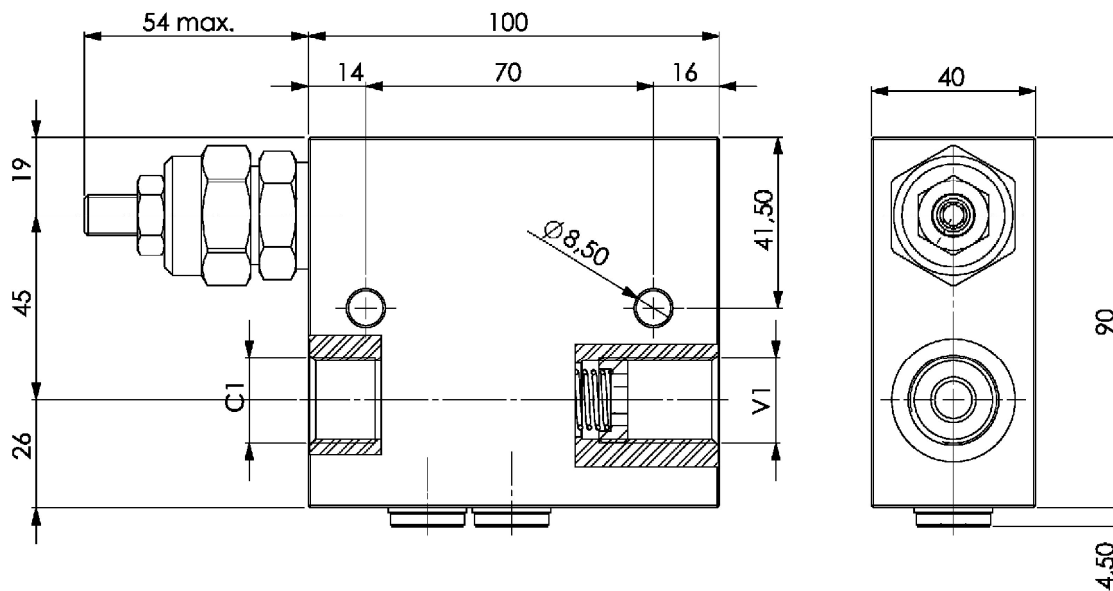

MOLLE - SPRINGS *				
Codice Code	Campo taratura min.-max. bar Adjustable pressure range bar	Increment. press. bar/giro vite Pressure increase bar/turn	Taratura standard bar Standard setting bar	Colore Color
05	5 - 50	10	5	Bianco White
10	30 - 100	20	30	Giallo Yellow
20	80 - 280	40	80	Verde Green
35	120 - 320	50	120	Rosso Red

REGOLAZIONI - ADJUSTEMENTS *		
Codice Code	Tipo - Type	
P	Vite esterna con esagono incassato Leakproof hex. socket screw	
R	Volantino e dado Handknob and locknut	
Z	Cappello antimanomissione Tamperproof cap	

ESEMPIO DI ORDINAZIONE - ORDERING CODE EXAMPLE

F P S Q **D** **70** **CB** **P** **1 / 2** **S** **20** *****

* P/R/Z:
Regolazioni - Adjustements

1/2 = 1/2+BSPP
 * 3/4 = 3/4+BSPP
 Connessioni V1/C1 . V1/C1 port sizes

* Materiale blocco: omettere se alluminio, S=acciaio
 Body material: omit if aluminium, S=steel

Guarnizioni . Seals:
 V=Viton *
 Omettere se BUNA-N . Omit if BUNA-N

%5+ / %10+ / %20+ / %35+
 Campi di taratura pressione
 Adjustable pressure range *