

Relief valve double effect for OMH-OMP-OMR motors / 40 lpm **H14012**

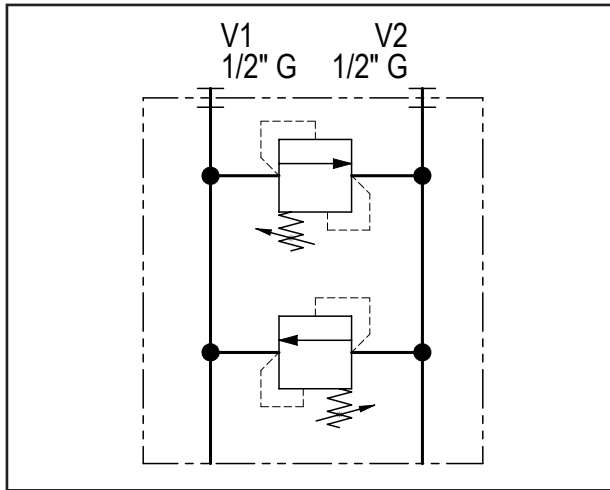

Technical data	
Max. pressure	250 bar
Max. flow	40 lpm
Weight	1,2 Kg
Manifold material	Aluminum
V1 / V2 ports	1/2" G

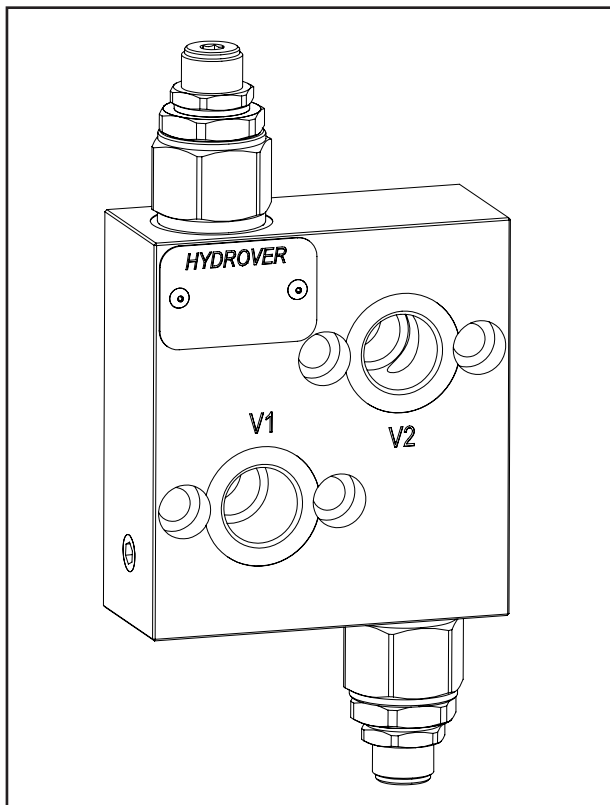

N°	Description	Q.ty
1	Bosch Rexroth relief valve VMD1.040 *	2
2	Ø 8,5 through hole for mounting with counterbore	4
3	OR 130 i. Ø 22,22 cross section 2,62	2

* for complete technical information, click on the blue link or go to the components section at the end of the catalogue

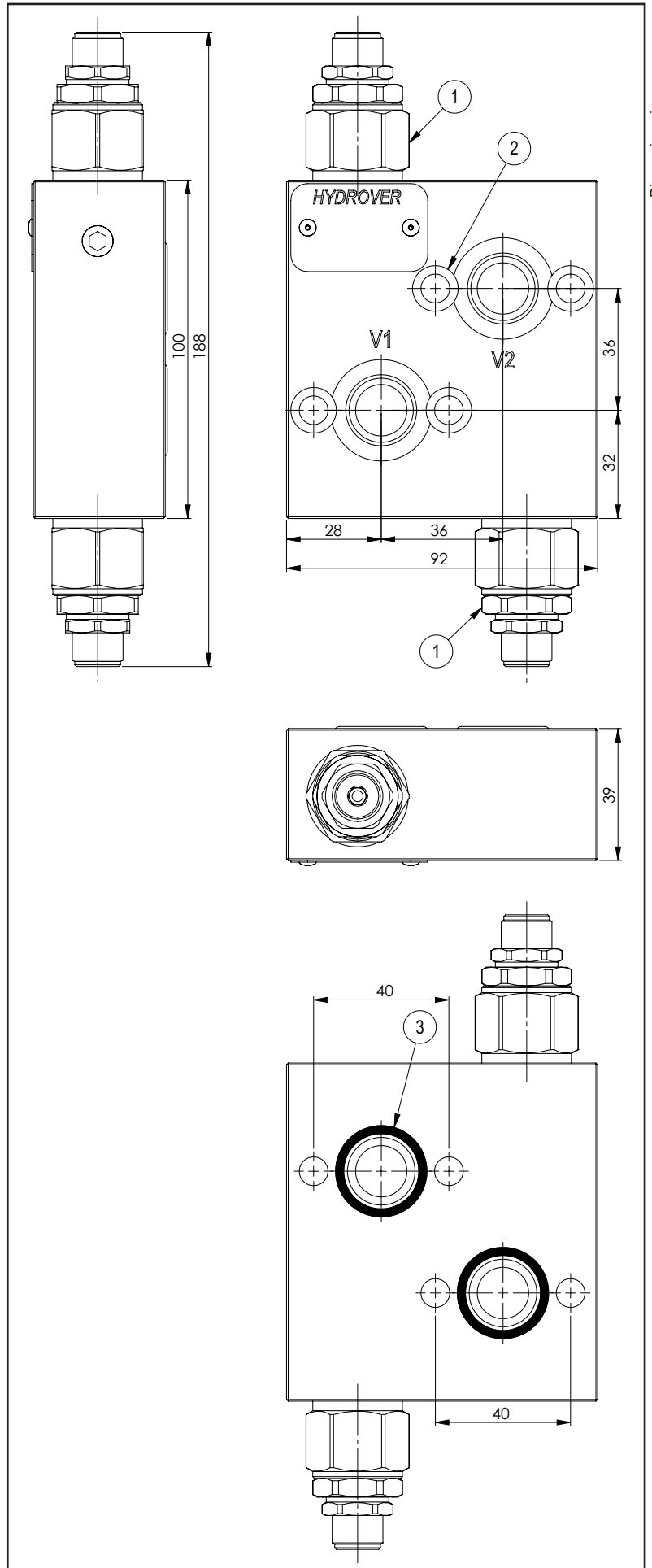

Dimensions in mm

Ordering code

H	1	4	0	1	2	A	-	-	-	-	-
---	---	---	---	---	---	---	---	---	---	---	---

Hydrover product

Product series

14 series - Valves for hydraulic motors

Product ID

Manifold material

Aluminum

Relief valve adjustment type on V1 *

Screw

= S

Relief valve adjustment pressure range on V1 *

25-120 bar

= 1

40-200 bar

= 2

200-350 bar

= 3

Relief valve adjustment pressure range on V2 *

1= 25-120 bar

2= 40-200 bar

3= 200-350 bar

Relief valve adjustment type on V2 *

S = Screw

* Omit if not required. To order the product without the pressure relief cartridge valves, omit the pressure range and the adjustment type options: H14012A.

The manifold will still be provided with the corresponding cavities.