

Technical data	
Max. pressure	250 bar
Max. flow	70 lpm
Weight	1,9 Kg
Manifold material	Aluminium
A / B / A1 / B1 / T ports	1/2" G

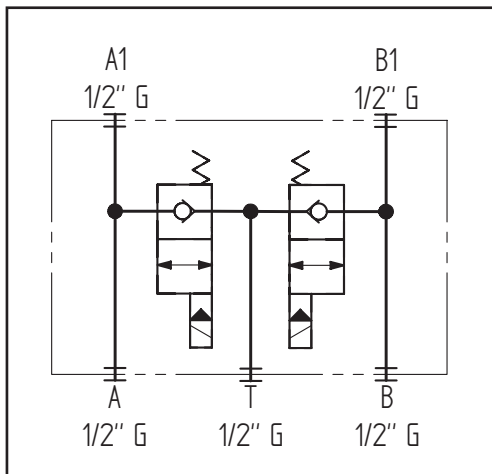

N°	Description	Q.ty
1	Connector DIN 43650 ISO 4400	2
2	M8x15 thread for mounting	2
3	Bosch Rexroth coil D36 CLASS H DIN 43650 ISO 4400 *	2
4	Bosch Rexroth solenoid valve OD.15.05.17-Y-000000 depicted without manual override.	2

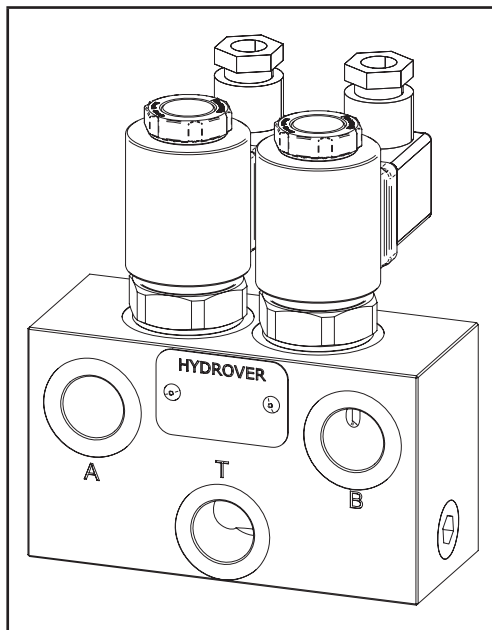
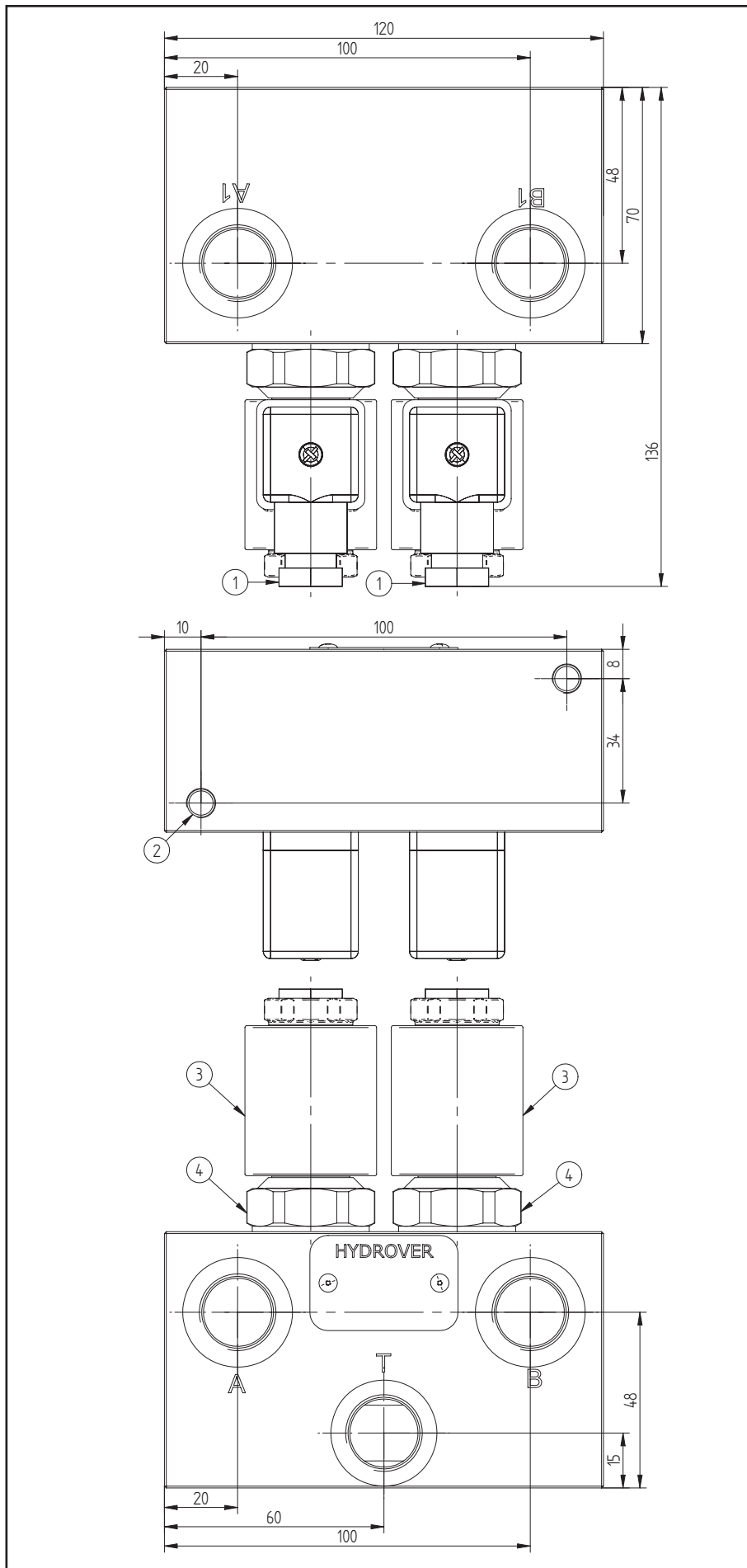

Dimensions in mm

* for complete technical information, click on the blue link or go to the components section at the end of the catalogue

Ordering code

H	1	7	0	1	3	A	-	-	-	-	-
---	---	---	---	---	---	---	---	---	---	---	---

Hydrover product

Product series

17 series - Inline valves

Product ID

Manifold material

Aluminium

Solenoid valves coil connection *

1 = DIN 43650 ISO 4400

Solenoid valves coil voltage *

OB =	12V DC
OC =	24V DC
OD =	48V DC
OU =	110V RAC
AH =	230V RAC

Solenoid valves manual override *

E0 =	Without
EV =	Screw

* Omit if not required. For example, to order the product without the solenoid cartridge valves, omit the coil connection, coil voltage, max. flow and manual override options: H17013A.
The manifold will still be provided with the corresponding cavities.