

Caratteristiche tecniche	
Pressione max.	210 bar
Peso	1,2 Kg
Materiale collettore	Alluminio
Attacchi A / B	3/8" G

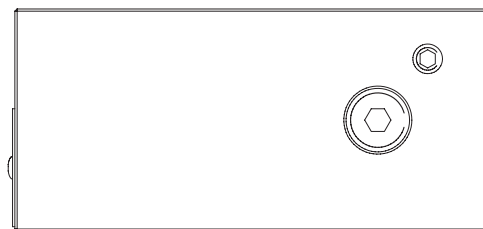
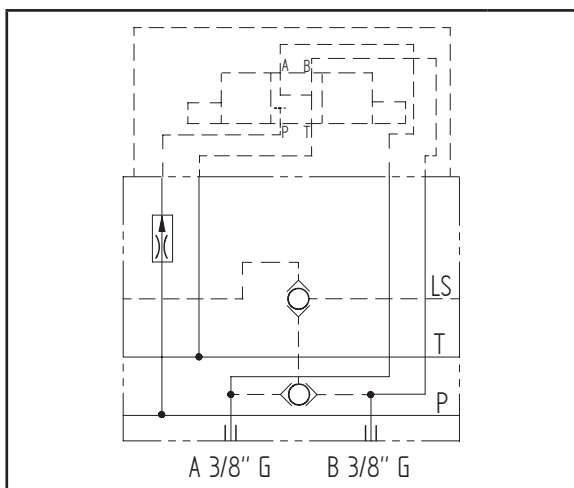
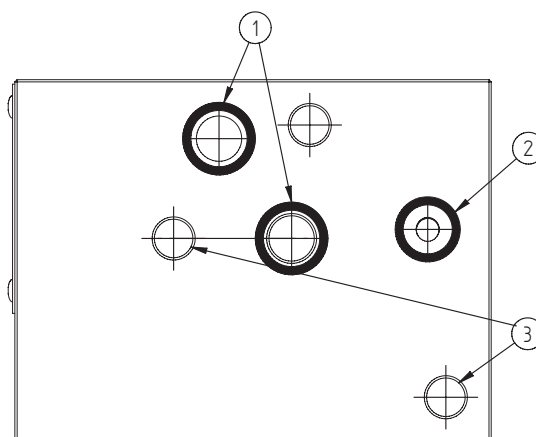
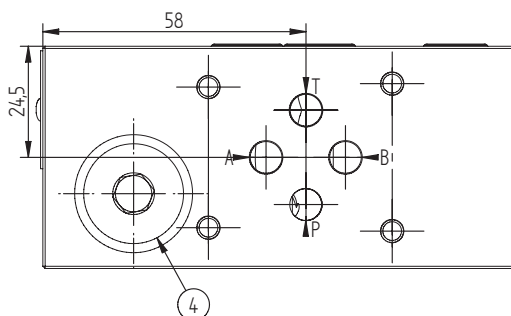
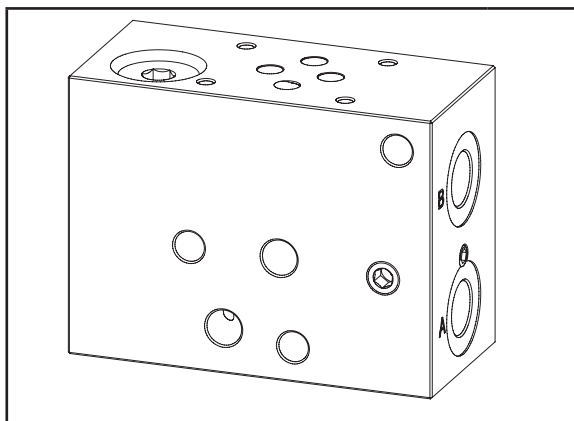

N°	Descrizione	Q.tà
1	OR 2050 Ø i. 12,42 filo 1,78 (P-T)	2
2	OR 2043 Ø i. 10,82 filo 1,78 (LS)	1
3	Foro passante Ø 8,5 per tirante	3
4	Valvola di controllo portata compensata a 2 vie Bosch Rexroth 0T.F1.00.02-Z *	1

* per caratteristiche tecniche complete cliccare sul collegamento blu o consultare a fine catalogo la sezione componenti

Codice d'ordinazione

H	3	2	0	5	A	-	_	_
---	---	---	---	---	---	---	---	---

Prodotto Hydrover

Serie prodotto

Serie 32 - Elementi componibili LS per valvole CETOP 3 in circuito parallelo

Indice prodotto

Portata regolata ± 10% a 100 bar

- 00 = Con regolatore da forare (4-10 lt/1)
- 04 = 4 lt/1
- 05 = 5 lt/1
- 06 = 6 lt/1
- 08 = 8 lt/1
- 10 = 10 lt/1
- 12 = 12 lt/1
- 14 = 14 lt/1
- 16 = 16 lt/1

Materiale collettore

Alluminio