

Technical data	
Max. pressure	250 bar
Weight	1,2 Kg
Manifold material	Aluminium
A / B ports	3/8" G

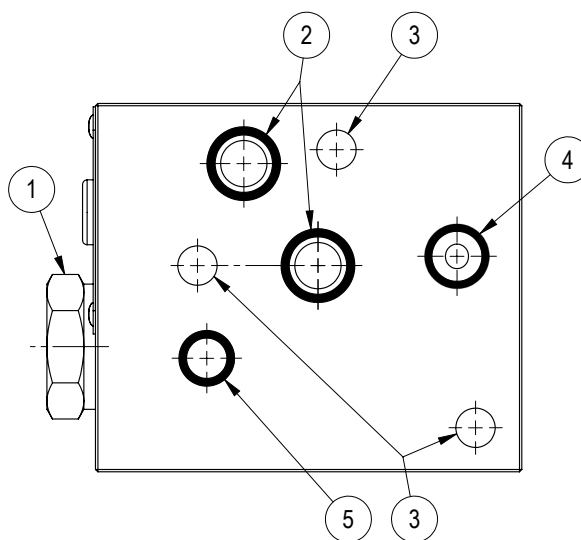
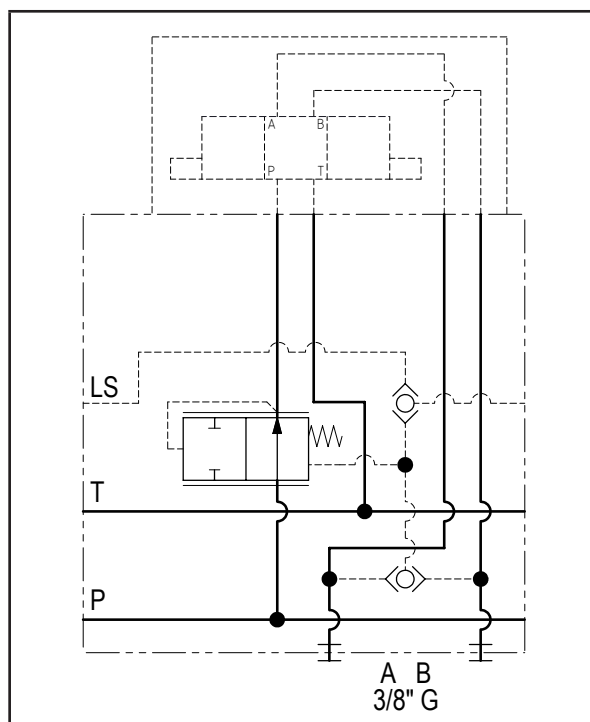
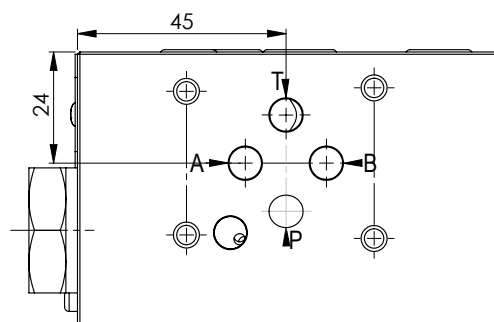
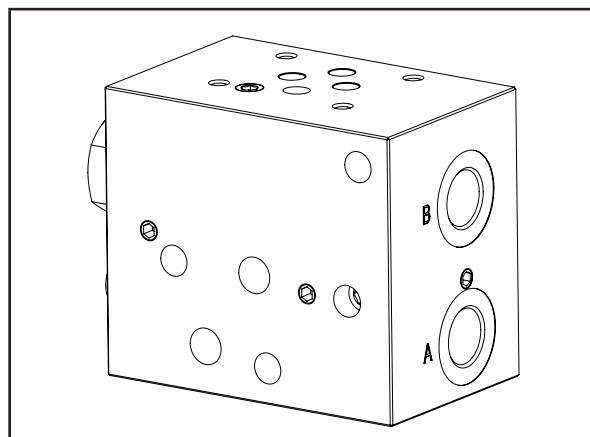

N°	Description	Q.ty
1	Pressure compensator	1
2	OR 2050 i. Ø 12,42 c. s. 1,78 (P-T)	2
3	Ø 8,5 through hole for tie rod	3
4	OR 2043 i. Ø 10,82 c. s. 1,78 (LS-FS)	1
5	OR 108 i. Ø 8,73 c. s. 1,78	1

Dimensions in mm

Ordering code

H	3	2	2	2	A
---	---	---	---	---	---

Hydrover product

Product series

32 series - Load sensing modular Cetop 3 subplates for parallel circuits

Manifold material

Aluminium

Product ID