

Caratteristiche tecniche	
Pressione max.	250 bar
Peso	1,2 Kg
Materiale collettore	Alluminio
Attacchi A / B	3/8" G

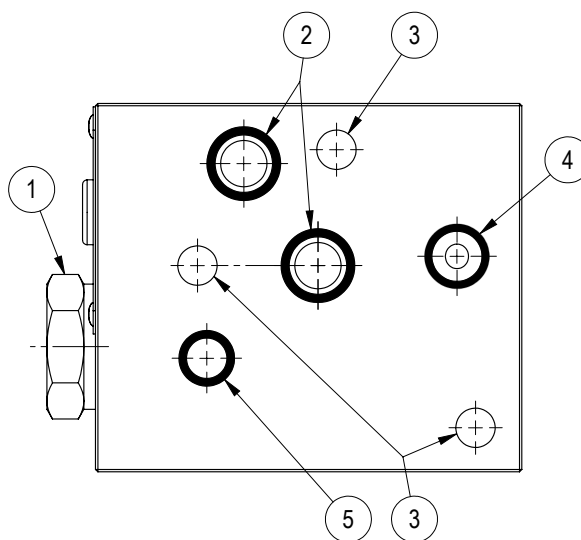
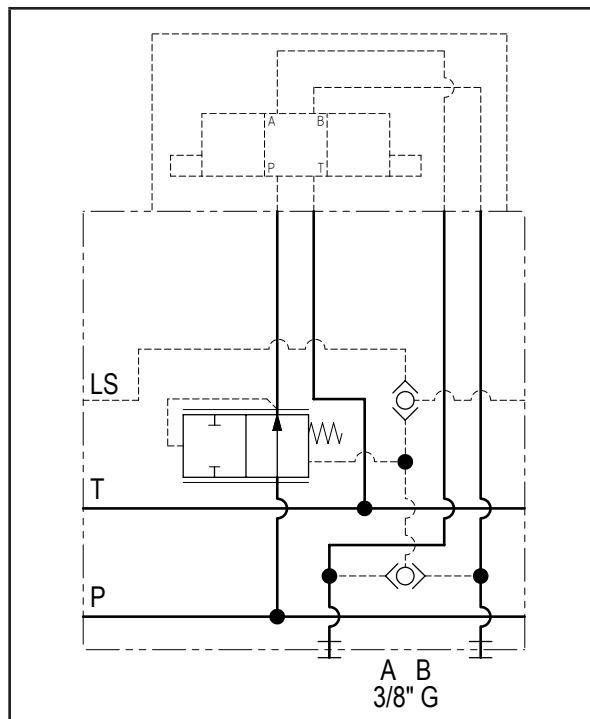
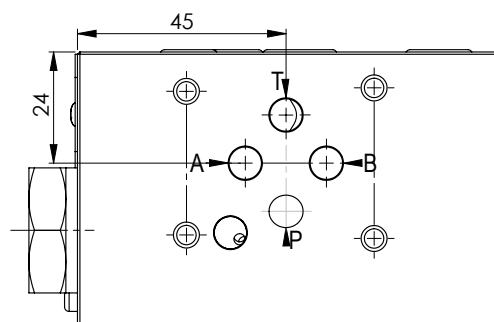
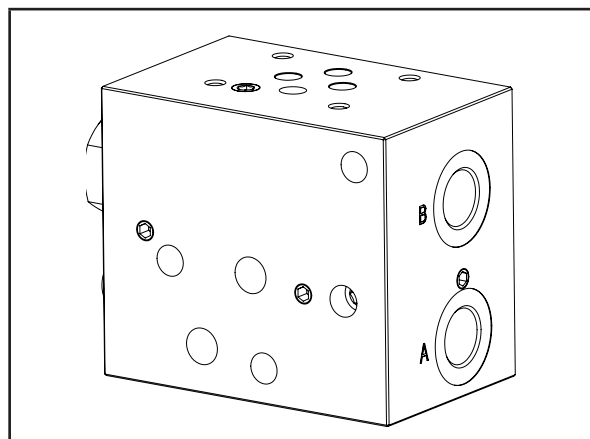

N°	Descrizione	Q.tà
1	Compensatore di pressione	1
2	OR 2050 Ø i. 12,42 filo 1,78 (P-T)	2
3	Foro passante Ø 8,5 per tirante	3
4	OR 2043 Ø i. 10,82 filo 1,78 (LS)	1
5	OR 108 Ø i. 8,73 filo 1,78	1

Codice d'ordinazione

H	3	2	2	2	A
---	---	---	---	---	---

Prodotto Hydrover**Materiale collettore**
Alluminio**Serie prodotto**Serie 32 - Elementi componibili LS per valvole
Cetop 3 in circuito parallelo**Indice prodotto**