

Intermediate subplate with 2 way compensated flow regulator
pilot operated check valves on A and B / 1 Cetop 3 station / side A-B ports

H3226

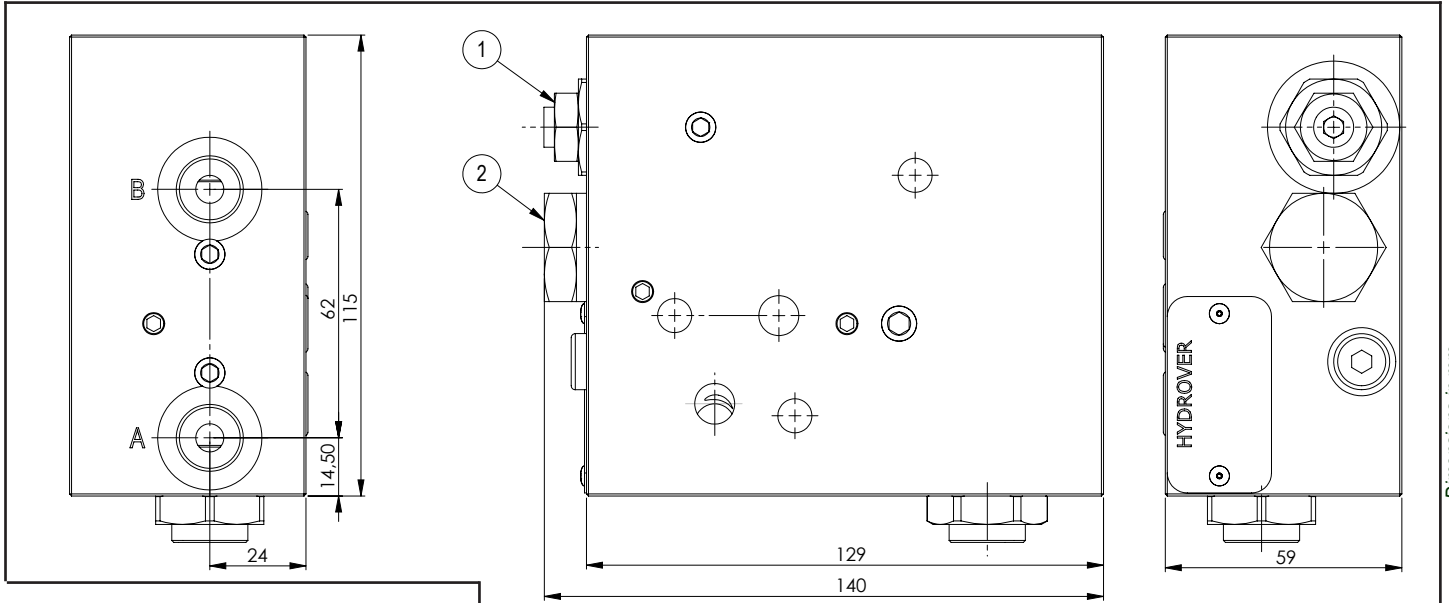

Dimensions in mm

Technical data	
Max. pressure	250 bar
Weight	2,6 Kg
Regulated max. flow	25 lpm
Manifold material	Aluminium
A / B ports	3/8" G

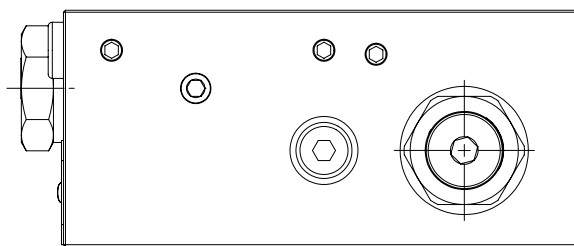
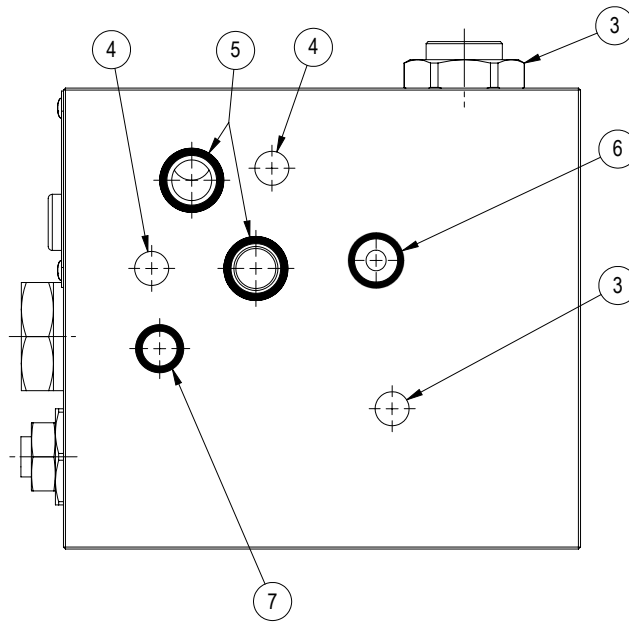
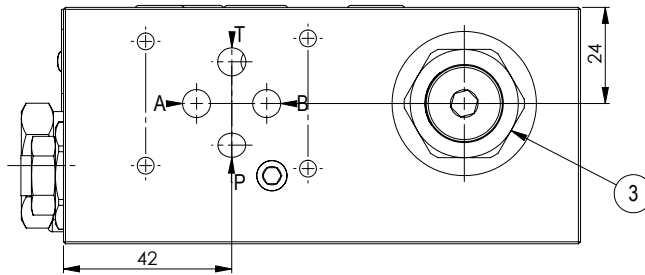
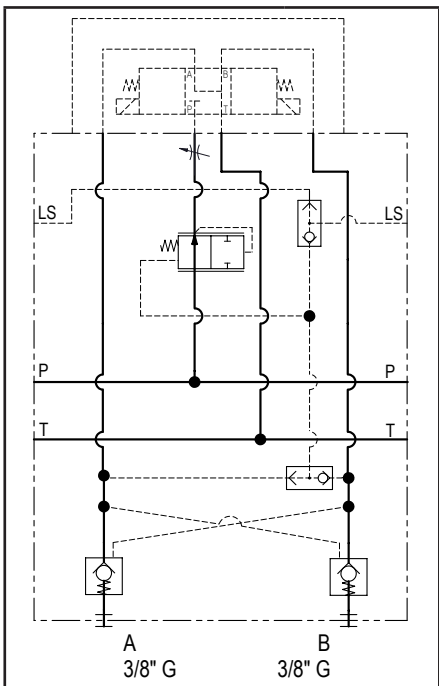
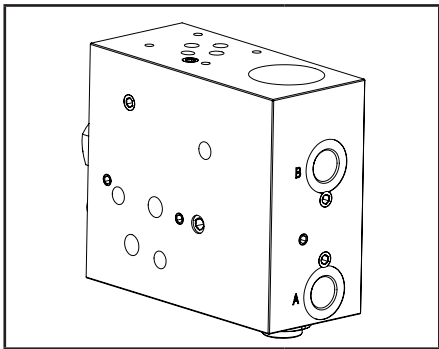

Ordering code

H	3	2	2	6	A
---	---	---	---	---	---

Hydrover product

Manifold material
Aluminium

Product series

32 series - Load sensing modular Cetop 3 subplates for parallel circuits

Product ID

N°	Description	Q.ty
1	Flow restrictor	1
2	Pressure compensator	1
3	Bosch Rexroth check valve VU-38 *	2
4	Ø 8,5 through hole for tie rod	3
5	OR 2050 i. Ø 12,42 cross section 1,78 (P-T)	2
6	OR 2043 i. Ø 10,82 cross section 1,78 (LS)	1
7	OR 108 i. Ø 8,73 cross section 1,78	1

* for complete technical information, click on the blue link or go to the components section at the end of the catalogue