

Dimensions in mm

Technical data	
Max. pressure	250 bar
Max. flow	80 lpm
Weight	2,7 Kg
Manifold material	Aluminium
A / B ports	3/4" G

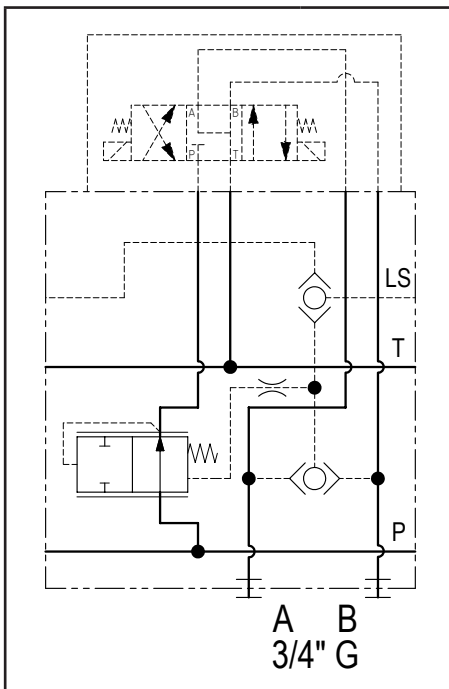
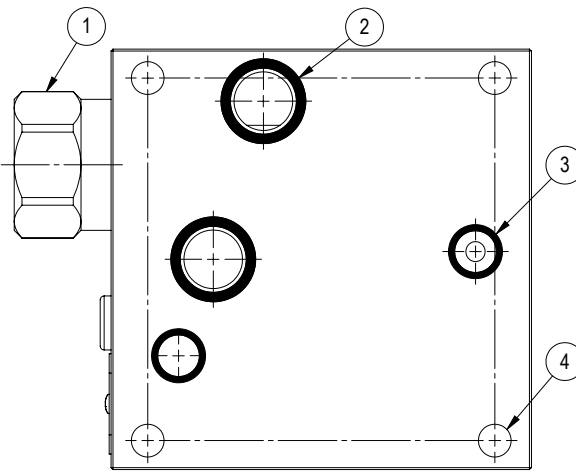
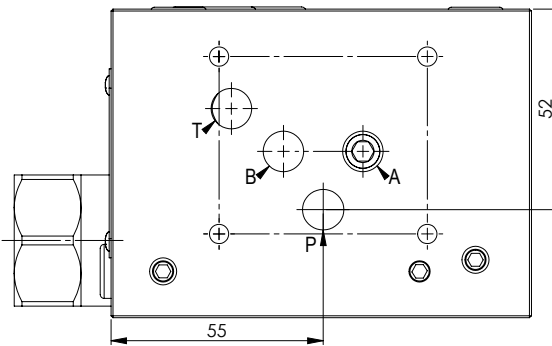
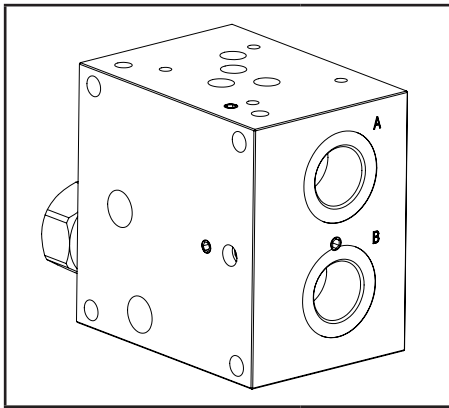

N°	Description	Q.ty
1	2 way compensator 5,5 bar spring	1
2	OR 3068 i. Ø 17,12 cross section 2,62 (P-T)	2
3	OR 2043 i. Ø 10,82 cross section 1,78(LS-FS)	2
4	Ø 8,5 through hole for tie rod	4

Ordering code

H	5	2	1	3	A
---	---	---	---	---	---

**Hydrover product**

**Product series**

52 series - Load sensing modular Cetop 5 subplates for parallel circuits

**Manifold material**  
Aluminium

**Product ID**