

Technical data	
Max. pressure	250 bar
Max. flow	100 lpm *
Weight	2,3 Kg
Manifold material	Aluminium

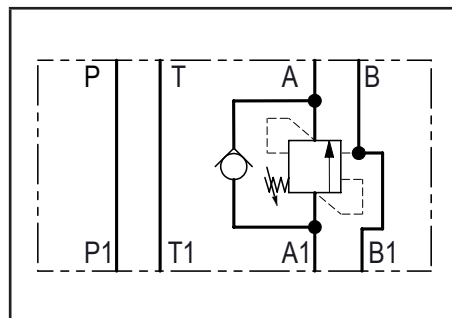

N°	Description	Q.ty
1	Bosch Rexroth counterbalance valve <b>VBSN-12A</b> *	1
2	OR 2050 i. Ø 12,42 cross section 1,78	5
3	Ø 6,5 through hole for mounting	4

\* for complete technical information, click on the blue link or go to the components section at the end of the catalogue

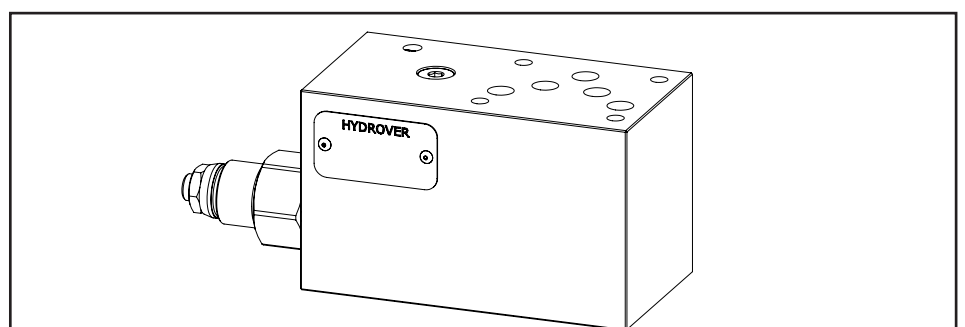

Ordering code

H	5	9	1	7	A	-	-	-
---	---	---	---	---	---	---	---	---

**Hydrover product**

**Product series**

59 series - Cetop 5 modular valves

**Product ID**

**Manifold material**

Aluminium

**Counterbalance valve pilot ratio**

4 = 4:1  
8 = 8:1

**Counterbalance valve adjustment pressure range**

2 = 70-210 bar  
3 = 140-350 bar

**Counterbalance valve adjustment type \***

S = Screw

\* Omit if not required. To order the product without the counterbalance cartridge valve, omit the adjustment type, pressure range and pilot ratio options: H5917A.  
The manifold will still be provided with the corresponding cavity.