

Technical data	
Max. pressure	280 bar
P1 max. flow	50 lpm *
P2 max. flow	100 lpm **
P3 max. flow	150 lpm **
Weight	43,9 Kg
Manifold material	Steel
MP1 / MP2 / MP3 ports	1/4" G
P1 / P2 / P3 ports	3/4" G
A / B ports	1" G
T1 / T2 ports	SAE 3000 1"1/4 flange
* Depending of the system power	
** Depending of the cylinder dimensions and the system power	

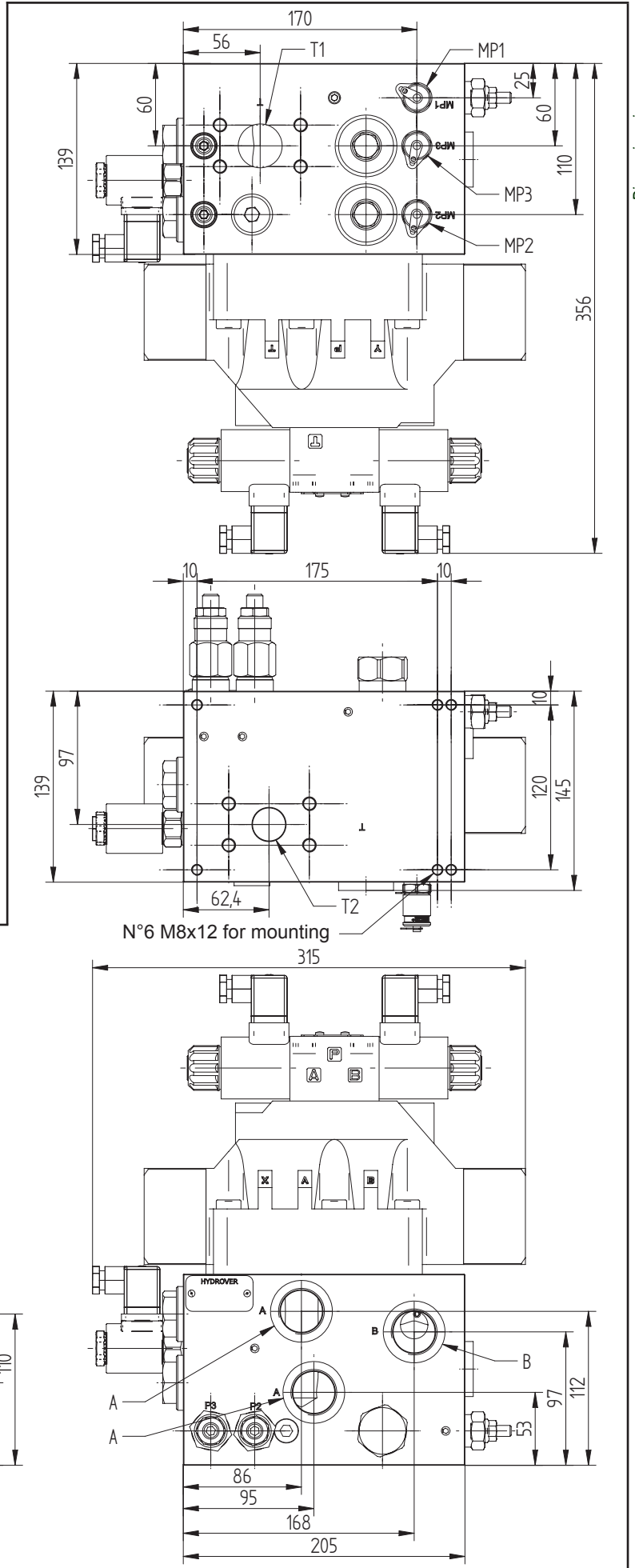

Dimensions in mm

Ordering code

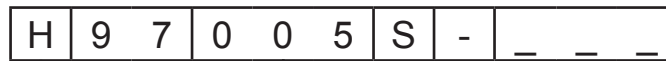

Hydrover product

Product series

97 series - Multifunctional integrated circuits

Product ID

Manifold material

Steel

Solenoid valves coil connection
1 = DIN 43650 ISO 4400

Solenoid valves coil voltage *

OB =	12V DC
OC =	24V DC
OU =	110V RAC
AH =	230V RAC

