



aerospace
climate control
electromechanical
filtration
fluid & gas handling
hydraulics
pneumatics
process control
sealing & shielding



L90LS

Mobile Directional Control Valve

Proportional, Load Sensing, Pre-compensated



ENGINEERING YOUR SUCCESS.

Catalogue layout

In addition to general information and basic technical data, this catalogue contains descriptions of the many optional functions you can specify for the L90LS, so that we may customize it to control your machine optimally.

Each function area of the valve is given as a subheading, followed by a brief description. When different options are available for a function area, the subheading is followed by an item number in square brackets, e.g. **Pressure relief valve [16]**. This is followed by a series of coded options, e.g. **PA1, PS, Y**, together with a brief description of what each code represents. Alternatively, one or more pressure, flow or voltage options are given.

On page 9 is a general circuit diagram, which shows the basic function areas of the L90LS, as well as the item numbers that represent them. The same item numbers are of course used in all sub-circuit diagrams elsewhere in the catalogue. Please note that, unless stated otherwise, all sections and views of the valves have been drawn as seen from the inlet section.

Computer-aided valve specification

We have developed a computer program to specify the L90LS on the basis of the criteria for each individual machine function. The program facilitates optimal configuration of the valve for maximum performance in different applications. It also generates documentation in the form of a detailed specification and hydraulic circuit diagram for your valve, as well as a unique ID number that is stamped into the valve data plate. Your valve specifications are then stored on our database to facilitate rapid identification in the event of service enquiries or re-ordering.

Early consultation with Parker saves time and money

Our experienced engineers have in-depth knowledge of different types of hydraulic system and the ways in which they work. They are at your disposal to offer expert advice on the best system for the desired combination of machine functions, control characteristics and economic criteria. By consulting Parker early in the project planning stage, you are assured of a comprehensive hydraulic system that gives your machine the best possible operating and control characteristics.

Conversion factors

1 kg	= 2.2046 lb
1 N	= 0.22481 lbf
1 bar	= 14.504 psi
1 l	= 0.21997 UK gallon
1 l	= 0.26417 US gallon
1 cm ³	= 0.061024 in ³
1 m	= 3.2808 feet
1 mm	= 0.03937 in
9/5 °C + 32	= °F

Parker reserves the right to modify products without prior notice. Typical curves and diagrams are used in this catalogue. Even though the catalogue is revised and updated continuously, there is always the possibility of errors. For more detailed information about the products, please contact Parker Hannifin.



WARNING – USER RESPONSIBILITY

FAILURE OR IMPROPER SELECTION OR IMPROPER USE OF THE PRODUCTS DESCRIBED HEREIN OR RELATED ITEMS CAN CAUSE DEATH, PERSONAL INJURY AND PROPERTY DAMAGE.

This document and other information from Parker-Hannifin Corporation, its subsidiaries and authorized distributors provide product or system options for further investigation by users having technical expertise.

The user, through its own analysis and testing, is solely responsible for making the final selection of the system and components and assuring that all performance, endurance, maintenance, safety and warning requirements of the application are met. The user must analyze all aspects of the application, follow applicable industry standards, and follow the information concerning the product in the current product catalog and in any other materials provided from Parker or its subsidiaries or authorized distributors.

To the extent that Parker or its subsidiaries or authorized distributors provide component or system options based upon data or specifications provided by the user, the user is responsible for determining that such data and specifications are suitable and sufficient for all applications and reasonably foreseeable uses of the components or systems.

Offer of Sale

Please contact your Parker representation for a detailed "Offer of Sale".

Contents	Page
General Information.....	4
Load sensing systems, LS.....	5
Technical Data	6-7
Hydraulic circuits	8-9
Inlet sections [15].....	10
Pressure relief valve [16]	14
Pressure setting [17].....	15
Differential pressure limiter, PLS [18].....	15
Load signal system [20].....	16
Pump-unloading function [22].....	17
Tank connection T1 [25].....	17
Pump connection P1 [26]	17
End section [30]	18
LS connection [31]	19
Pump connection P2 [32]	19
Counter pressure valve / tank connection T2 [33]	19
Tank connection T3 [34].....	19
Internal-pilot pressure supply [37]	19
Pilot filter [39].....	20
Tank connection for pilot circuit [40].....	20
Spool Section	21
Basic variants of spool section [47]	21
Material of spool section [48].....	21
Spool actuators [50].....	22
Directly operated actuators, with open spool-end	22
ON/OFF remote-controlled actuators, with open spool-end	23
Remote-controlled actuators, proportional spool actuators with open spool-end ..	23
Lever brackets [51]	23
Directly operated actuators with enclosed spool-ends	24
Proportionally remote-controlled actuators, with enclosed spool-ends	25-27
Connector types [56]	27
Lever bracket [51]	28
Pilot restrictor [55 A, B].....	28
Spool function [60].....	29
Flow requirements [61 A, B]	29
Spool symbols	29
Choice of spool.....	29
Area ratios [62]	30
Load characteristics [63].....	30
Force feedback [64 A, B]	30
Pressure compensator / load-hold check valve [66].....	31
Damping of pressure compensator [67]	31
Spool designations [69]	31
Flow settings [72].....	32
Feed-reducing valve [75]	32
Setting of feed reduction in the A-port [75A] and [75B]	32
Port relief and/or anti-cavitation valves [76 A, B]	33
System functions	34
System signal lines [80].....	34
Individual LS connection [81].....	34
Two-speed function [82].....	35
Internal connection of service port [85]	35
Connectors	35
Function manifolds [90-99]	36
Direct Levers.....	37
Dimensional drawings, valve	38-39
Dimensional drawings, spool actuators with open spool end	40
Dimensional drawings, spool actuators with open and closed spool ends.....	41
Dimensional drawings, spool actuators with closed spool end.....	42

[00] refererar till positionsnummer i kundspecifikationen

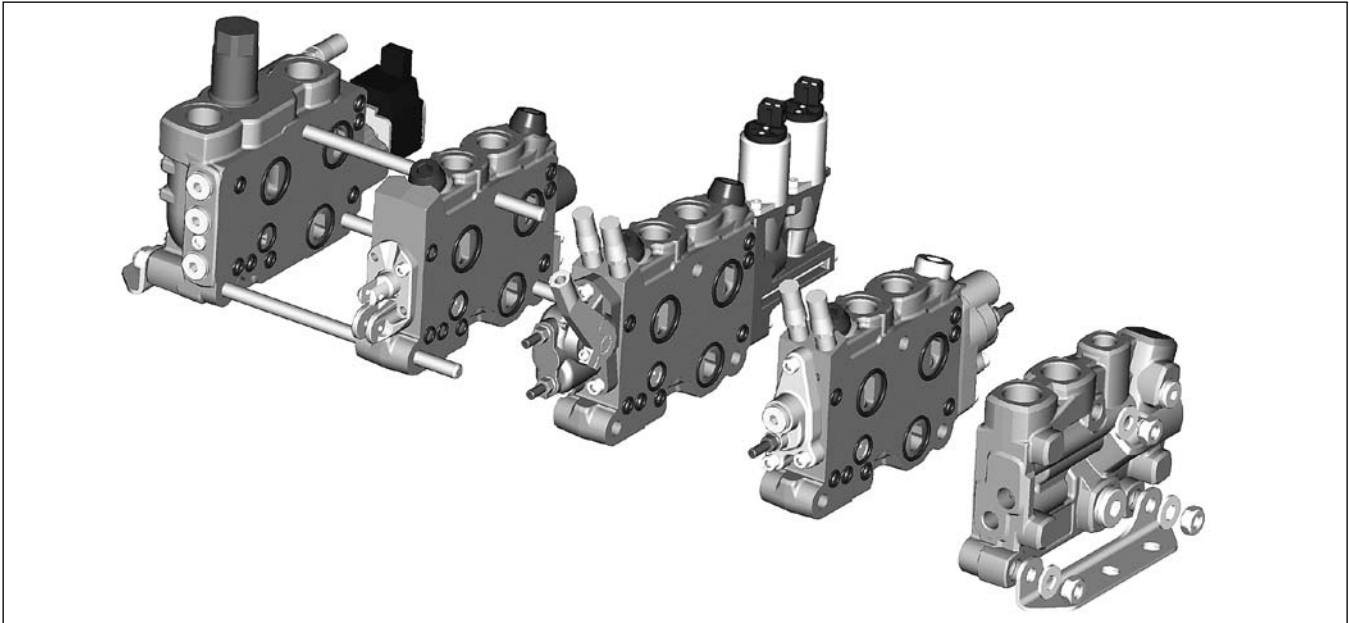

The L90LS is a stackable, multi-section, load-sensing, pressure-compensated directional valve for mobile machines such as cranes, skylifts, forklift trucks, platform trucks, excavators and harvesters. It is designed for working pressures of up to 320 bar and a maximum pump flow of 200 l/min. The valve can be given excellent simultaneous-operating characteristics, which enable several machine functions to be operated responsively at the same time, regardless of the sizes of individual loads.

To facilitate precise customization for different applications, the L90LS is of wholly modular construction. Each valve is therefore built to order, so that it incorporates exactly the valve functions and values needed to control the given machine in an optimal way.

Compact, integral system construction

The total modularity of the L90LS gives unique opportunities to integrate a wide range of normally external functions into the valve. Such functions can be common or specific to individual spool-sections, so that widely differing criteria for individual machine functions can be met in just one valve. This enables compact, tailored, logical, pre-tested, service-friendly system solutions to be created for many different types of machine.

In situations where flow demands vary so greatly that two separate directional valves would normally be required, the L90LS can, with the aid of a special combo-inlet, be flanged to a larger valve such as the K170LS or K220LS to give a compact, unitized system solution and optimum economy.

Wide range of spool actuators

The spools in the L90LS can be actuated

directly by means of levers or remotely by pneumatic, electro-pneumatic, hydraulic or electro-hydraulic remote control. Some of our remote-controlled spool actuators can be fitted with a supplementary direct lever to give a dual-control and/or emergency facility. The wide range of actuating options gives the machine designer great freedom in terms of control criteria and component location.

Customisation and economy

The L90LS can be tailored optimally to control either simple or complex machine-functions and combinations thereof. Its facilities for integrating total, wholly customized solutions for a wide range of applications give low system costs and minimal energy consumption.

Safety and serviceability

The design of the L90LS makes it easy for machine manufacturers to comply with national and international safety regulations, such as those contained in the EC Machinery Directive. Special safety functions for machines such as cranes and skylifts can be integrated into the valve in a logical and simple way. With all system functions contained in a robust, compact, pre-tested unit with minimal external pipework, overall safety and reliability is greatly improved at the same time as servicing and the training of personnel is made much easier.

Spool sections and flow rates

The L90LS can be supplied in combinations of 1-12 spool sections or in combination with special function manifolds fitted between spool sections. The maximum recommended flow rate per spool section is 125 l/min, or 90 l/m when equipped with a pressure compensator.

Examples of optional functions

Depending on the application and operating criteria of the machine, a wide range of common, section- or port-specific optional functions can be integrated into the L90LS. Examples include:

- a bypass function in the inlet section for systems fed by fixed pumps.
- a pump-unloading function that blocks the pump inlet when activated, thus enabling an emergency-stop function to be incorporated into the system.
- section-specific pressure compensation.
- port-specific relief and anti-cavitation functions.
- port-specific feed reduction.
- port-specific force-feedback functions that enable force-sensing and also provide a hydraulic ramp function.
- a load-signal copying function to eliminate micro-sinking.
- a built-in pilot-pressure function in the end section.
- a counter pressure function that gives exceptionally good make-up characteristics and the possibility of unloading lowering movements.
- section-specific two-speed functions that enable switching between performance and precision work in machines such as cranes and skylifts.
- automatic stopping functions for selected machine movements in the event of overload or the reaching of other pre-determined limits.
- priority for machine functions such as brakes and steering.
- Flow distribution between different consumers at maximum flow take-off from the pump.

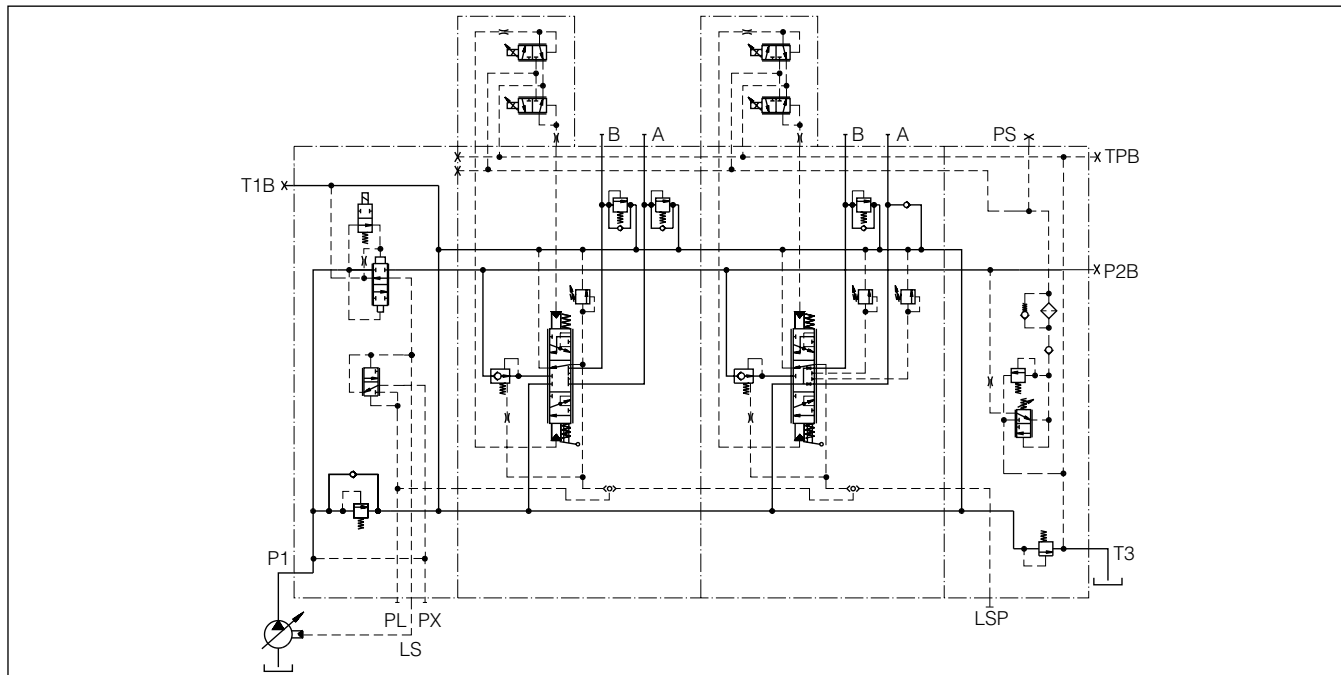

Principle circuit diagram for valve with load sensing.

Load sensing systems, LS

In the load sensing system both pressure and flow are modulated to match immediate needs from the consumers, with a pressure level corresponding to the heaviest load at that moment.

The load signal system of the L90LS consists of an appropriate number of changeover valves, which compare the load signals from the spool sections. The highest load pressure is transmitted and controls the variable pump either directly or via a copy spool.

In order to achieve good operating characteristics, the pump should be sized to deliver flow equal to the sum of all simultaneously working functions. If the control pressure difference cannot be maintained, the operating characteristics of the valve can quickly deteriorate, and the controlled functions will influence each other, progressively resulting in lower loads receiving more flow than the higher ones.

In common with a constant flow system, simultaneously working functions should have approximately the same pressure requirement or they should be divided into separate circuits for high operating efficiency.

Operating characteristics

With a correctly adjusted L90LS valve, the operating characteristics of the system are very good. The constant differential pressure maintained by the pump means that the flow to the heaviest load in a load sensing system is always pressure compensated.

However, load sensing does not mean that other functions are pressure compensated. To achieve good operating characteristics, the spools should be adapted for each function.

L90LS valves are designed for remote control and have pressure-compensated spools. This means that the regulated flow remains constant at a certain lever position, regardless of pressure variations in the system.

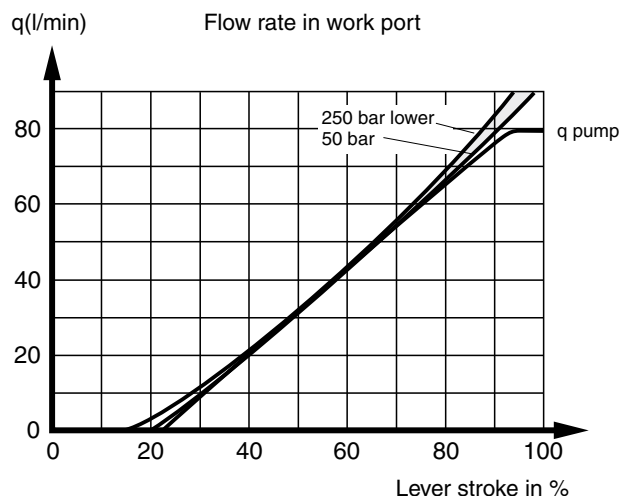

In the L90LS equipped with PC, ECS and ECH closed spool-actuators, the spools are pressure compensated, with the result that the load's influence on speed is negligible.

When there are demands for very good simultaneous-operating characteristics or intensive, multi-section operability and responsiveness, individual spool-sections in the L90LS can be equipped with integral pressure-compensators. Sections so equipped are not then influenced by other simultaneously-operated machine functions, regardless of the variations in loads, provided there is sufficient pump capacity.

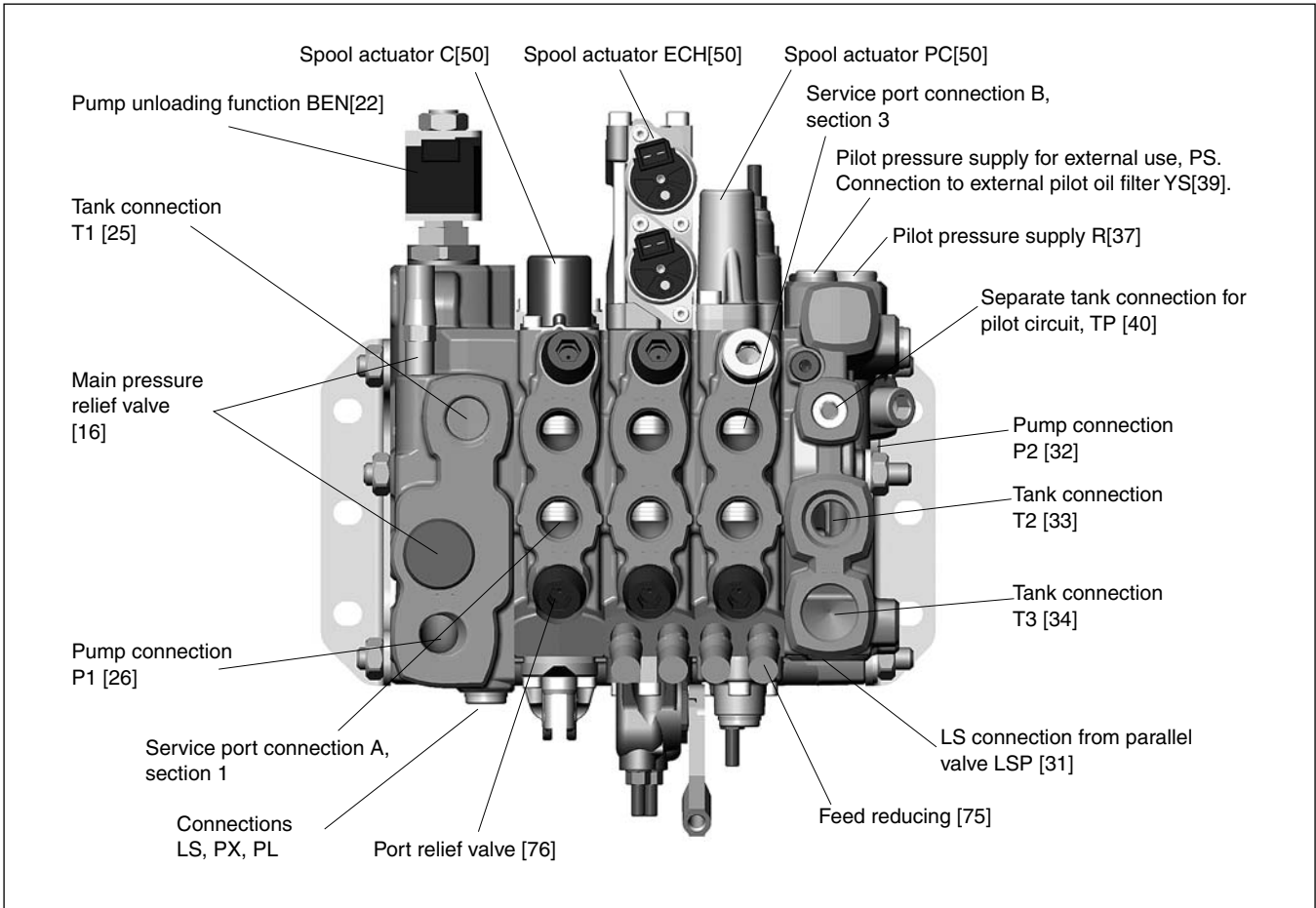

Pressures

Pump connection	max. 260/320 bar* (3800/4600 psi)
Service ports	max. 280/350 bar* (4000/5000 psi)
Tank connection	max. 20 bar (290 psi)

* Stated pressures are absolute shock pressures, valid for grey / nodular iron.

Flow rates, recommended

Pump connection	max. 200 l/min (50 US gpm)
Service port, with pressure compensator	max. 90** l/min (24 US gpm)
Service port, without pressure compensator	max. 125** l/min (33 US gpm)
Return from service port	max. 150 l/min (40 US gpm)

Leakage from work port over spool

From A or B port: max. 30 cm³/min (1.83 cu.in/min) at 250 bar (3625 psi), oil temperature 50 °C (122 °F) and viscosity 30 mm²/s (cSt).

** Depending on spool variant.

Feed reducing valves

Setting range	25 - 330 bar (363-4785 psi)
---------------	-----------------------------

Internal pilot pressure

Fixed setting	22, 35 or 43 bar (320, 508 or 625 psi)
---------------	--

Filtration

Filtration must be arranged so that Target Contamination Class 20/18/14 according to ISO 4406 is not exceeded. For the pilot circuit, Target Contamination Class 18/16/13 according to ISO 4406 must not be exceeded.

Temperature

Oil temperature, working range +20 to 90 °C (68 to 194 °F)*

Hydraulic fluids

Best performance is obtained using mineral-base oil of high quality and cleanness in the hydraulic system.

Hydraulic fluids of type HLP (DIN 51524), oil for automatic gearboxes Type A and engine oil type API CD can be used.

Viscosity, working range 15-380 mm²/s**

Technical information in this catalogue is applicable at an oil viscosity of 30 mm²/s and temperature of 50 °C using nitrile rubber seals.

- * Performance efficiency will be reduced if outside the ideal values. These extreme conditions must be evaluated by the user to establish suitability of the products performance.
- ** Product operating limits are broadly within the above range, but satisfactory operation within the specification may not be accomplished. Leakage and response will be affected when used at temperature extremes and it is up to the user to determine acceptability at these levels.

Weights

Inlet section	5.5 kg	12.1 lb
End section	4.2 kg	9.3 lb
Combo-inlet	11.5 kg	25.4 lb

Combined spool-end section, MU compared to spool section below adds 1.2 kg (2.6 lb)

Spool section with spool actuator:		
C, B3	4.1 kg	9.0 lb
ACE	5.2 kg	11.5 lb
CH, CHB3, CHX, PC	4.5 kg	9.9 lb
PCH	4.7 kg	10.4 lb
EC, ECS,	5.2 kg	11.5 lb
ECH, ECHL	5.4 kg	11.9 lb

Surface treatment (painted) [07]

- P** Primed valve, black. Primer only
- X** Unpainted

The paint is only a primer. For full corrosion protection, the valve must be painted with an outer coat.

Connections

Unless stated otherwise, all standard connections are available in two versions: G-version (BSP pipe thread) for flat seal (type Tredo) as per ISO 228/1 and UNF-version for O-ring seal as per ISO 11926-1.

Connection	In section	G-version.	UNF-version
P1	inlet section	G 3/4	1 1/16-12 UN-2B
T1	inlet section	G 3/4	1 1/16-12 UN-2B
P1	combo-inlet CA/CL	Flange SAE 1 High pressure ISO 6162-2	
T1	combo-inlet CA/CL	Flange SAE 1 1/4 Std pressure ISO 6162-1	
T2	combo-inlet CA/CL	G 1	1 5/16-12 UN-2B
LS, PL, PX, AS2	inlet, combo-inlet CA/CL	G 1/4	9/16-18 UNF-2B
P2	end and spool/end section MU	G 1/2	7/8-14 UNF-2B
T2, T3	end and spool/end section MU	G 3/4	1 1/16-12 UN-2B
TP	end and spool/end section MU, combo-inlet CA/CL	G 3/8	3/4-16 UNF-2B
PS	end and spool/end section MU, combo-inlet CA/CL	G 1/4	9/16-18 UNF-2B
LSP	spool/end section MU	9/16-18 UNF-2A (ORFS pipe end, male)	
LSP	end section	G 1/4	9/16-18 UNF-2B
YS	end section, combo-inlet CA/CL	G1/4	9/16-18 JIC (37°) (male)
A, B	spool section	G 1/2	7/8-14 UNF-2B
PC	spool section	G 1/4	9/16-18 UNF-2B
ACE, ACEF, ACP	spool section	G 1/8	1/8-27 NPTF
LSA/LSB	spool section	G 1/8	7/16-20 UNF-2B

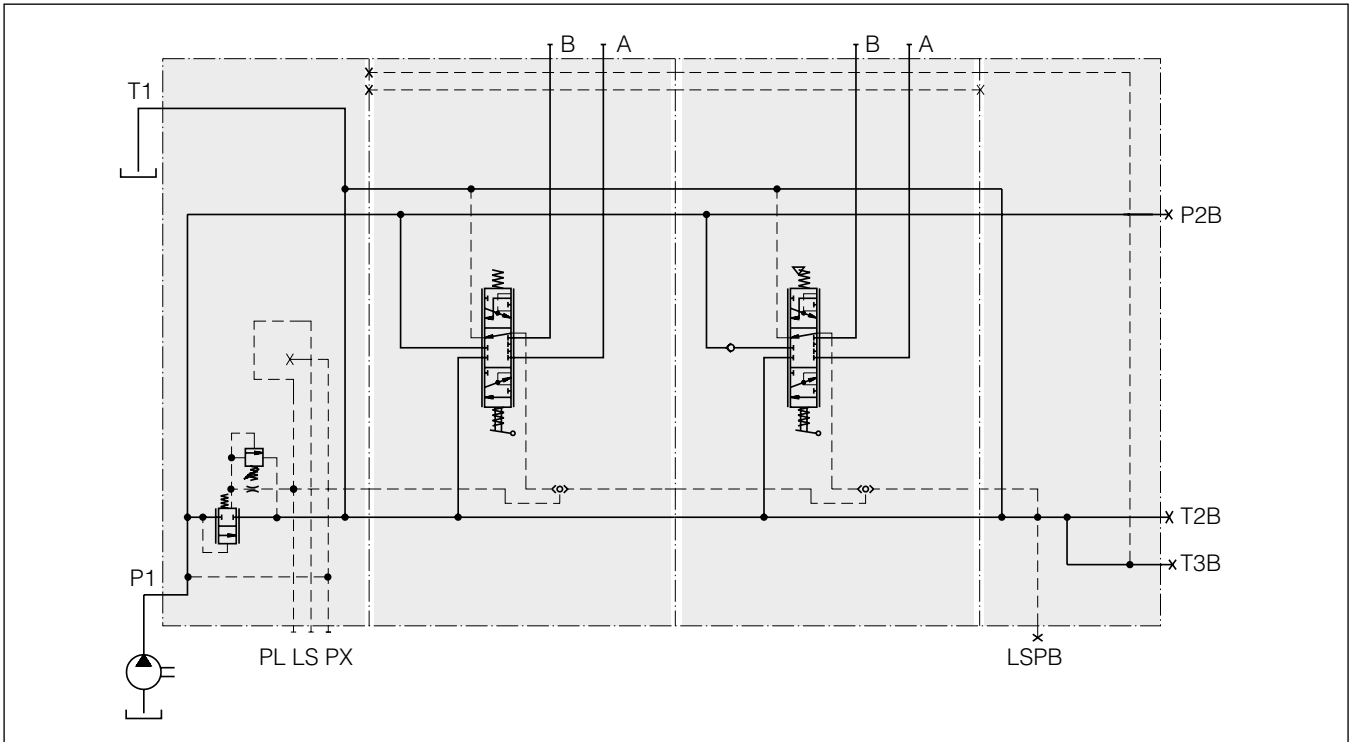

L90LS with levers for direct spool actuation and equipped with bypass for systems fed by pumps with fixed displacement.

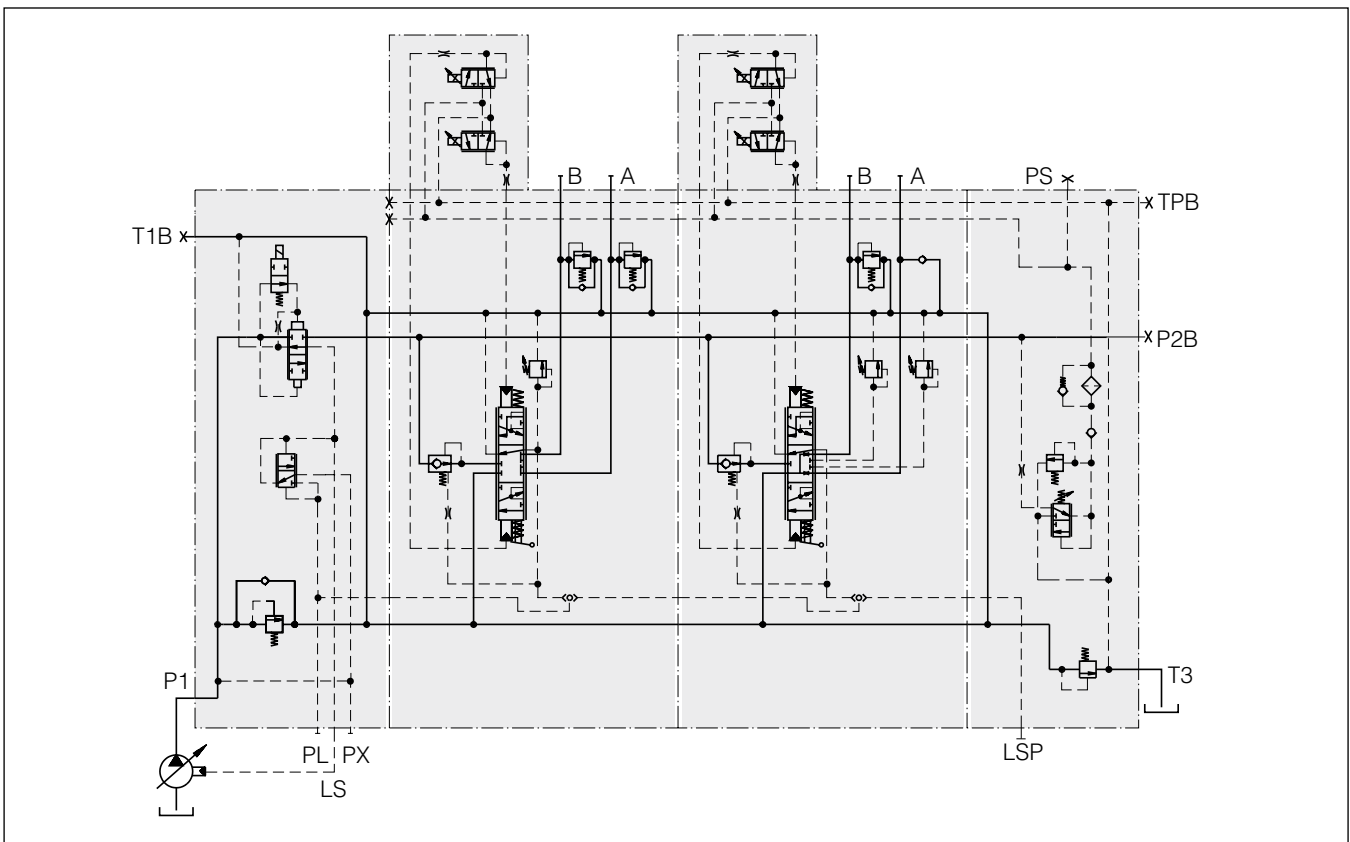

L90LS with electro-hydraulic remote-controlled spool actuators and equipped with direct-acting main pressure relief valve for systems fed by LS pumps, pump-unloading function, integrated

pilot-oil supply, counter pressure function, section-specific pressure compensators, port-specific feed reducing valves, port-relief and anti-cavitation valves, etc.

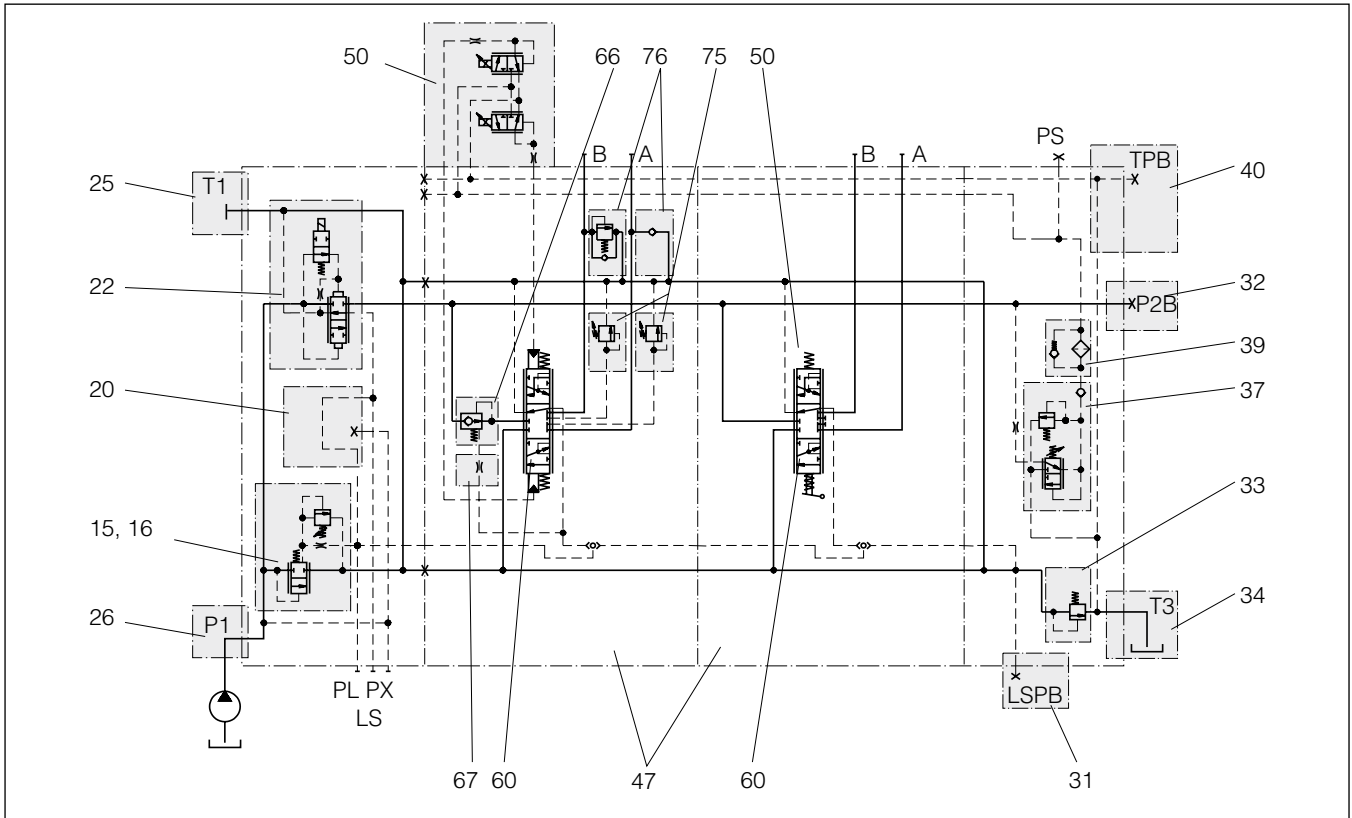

Hydraulic circuit diagram showing basic functions of L90LS.

The item numbers in the hydraulic circuit diagram and table below refer to the valve function areas for which different options are available. The valve in the example above is

equipped according to the description below. For other equipment alternatives, see under respective valve-function area [Item number] in catalogue.

Item No.	Code	Description	Item No.	Code	Description
15	CFC	Inlet with bypass for systems with fixed pump.	47	TTT	Section 1 equipped with pressure compensator, separate feed reducers for A- and B-ports, and prepared for port relief valves in both service ports.
16	PS	Pilot-operated main pressure relief valve.	000		Section 2 without pressure compensator, feed reducer or port relief valve.
20	KB	Prepared for load-signal copying.	50	EC	Section 1 equipped with proportional electro-hydraulic remote control.
22	BEN	Electrically activated pump-unloading function that blocks the pump and unloads the load signal.	CH		Section 2 equipped for direct operation with spring centring.
25	T1X	Tank connection in the inlet open for by-pass flow and tank gallery to spool section 1 plugged.	60	D	Sections 1 and 2 equipped with spool for double-acting function, with service ports blocked in neutral position.
26	P1	Pump connection in inlet open.	66	K	Pressure compensator with built-in check valve function.
31	LSPB	Load-signal connection for parallel-connected valve plugged.	67	0.8	Restriction of load signal to pressure compensator.
32	P2B	Pump connection plugged.	75		Pressure setting for feed reducers in A- and B-ports.
33	MF	Counter pressure valve with fixed setting.	76A	N2	Anti-cavitation valve in A-port.
34	T3	Tank connection open.	76B		Pressure setting for combined port-relief and anti-cavitation valve in B-port.
37	R	Pressure reducing valve with separate safety valve for internal pilot pressure supply.			
39	S	Internal coarse filter for pilot circuit.			
40	TPB	Prepared for separate tank connection from pilot circuit.			

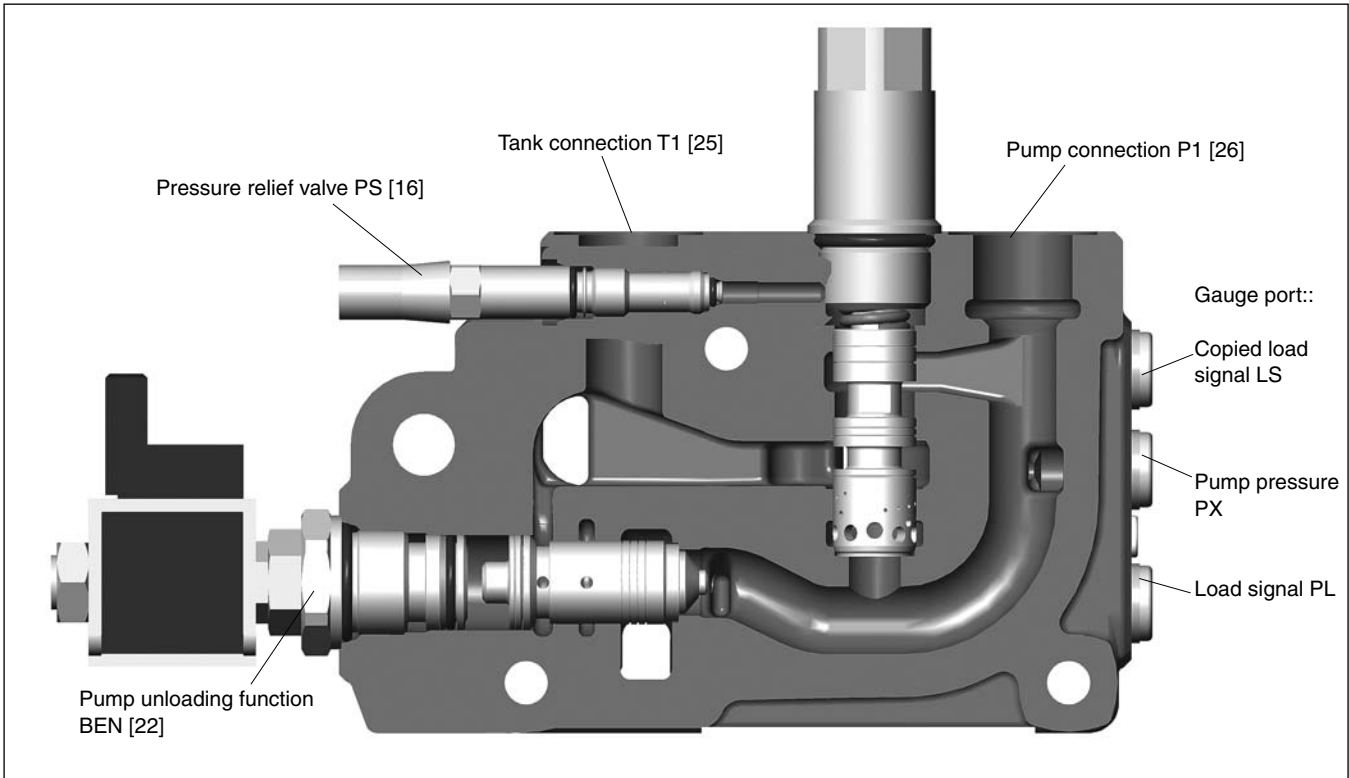

Inlet section CFC alt. LS1 with pump unloading function.

The inlet section is available in several basic variants; one for fixed pumps, four for systems with variable pumps and a simple plate for use when none of the inlet section's integrated functions is required. Inlet sections are equipped with pump and tank connections, a connection for the load signal to variable pumps and gauge ports for measuring the pump and load-signal pressures. In all basic variants, the pump connection P1 [26] and tank connection T1 [25] are open, while the other connections

are plugged. The variant for fixed pumps can be converted easily in the field to work with variable pumps, and vice versa. (CFC ↔ LS1).

Functions for maximum pressure relief, copying of the load signal and pump unloading (which blocks the hydraulic energy supply to the valve) can be integrated into the inlet section.

Inlet sections [15]

CFC Inlet section for systems with fixed pump. The section is equipped with an adjustable, pilot-operated pressure relief valve, PS [16], which protects the pump and inlet side of the valve. A built-in bypass regulates excess oil directly to tank. The bypass pressure level is controlled by the load signal, and is approx. 10 bar above the actual load-signal pressure.

LS1 Inlet section for systems with variable pump. Equipped with an adjustable, pilot-operated pressure relief valve, PS [16], which protects the pump and inlet side of the valve.

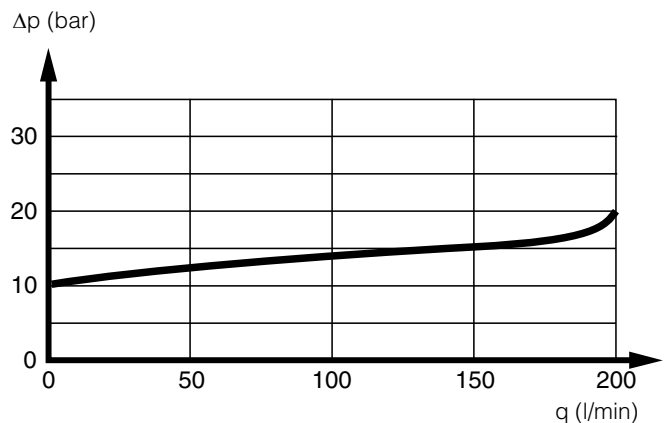

CFC – Idling (no load) pressure drop over bypass. P1 –T1.

LS2 Inlet section for systems with variable pump. Equipped with a non-adjustable, direct-acting pressure relief valve, PA1 [16], which protects the pump and inlet side of the valve. The LS2 variant is normally equipped with a copy function for the load signal, KS [20].

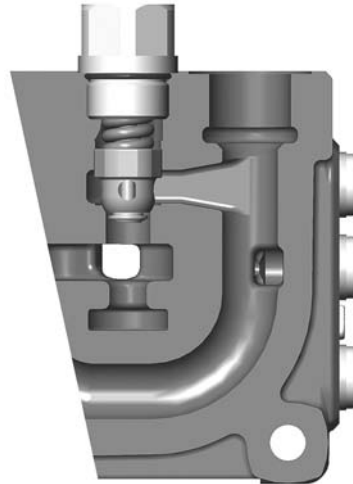

Inlet section LS2

AS Inlet section with flow distribution function for systems with variable pump. The section distributes the pump flow between activated spool sections fitted with compensator type KAS [66], at maximum flow take-off from the pump. With other inlet types, the consumer working the hardest receives no flow, which instead goes to the consumer with the lowest load. The section is equipped with a load pressure limiting valve, PLM [16], and a differential pressure limiting valve (pump pressure-load pressure), PLS [18]. Valves with AS inlet are located closest to the pump in a multi-valve system with the load signal connected to the pump regulator.

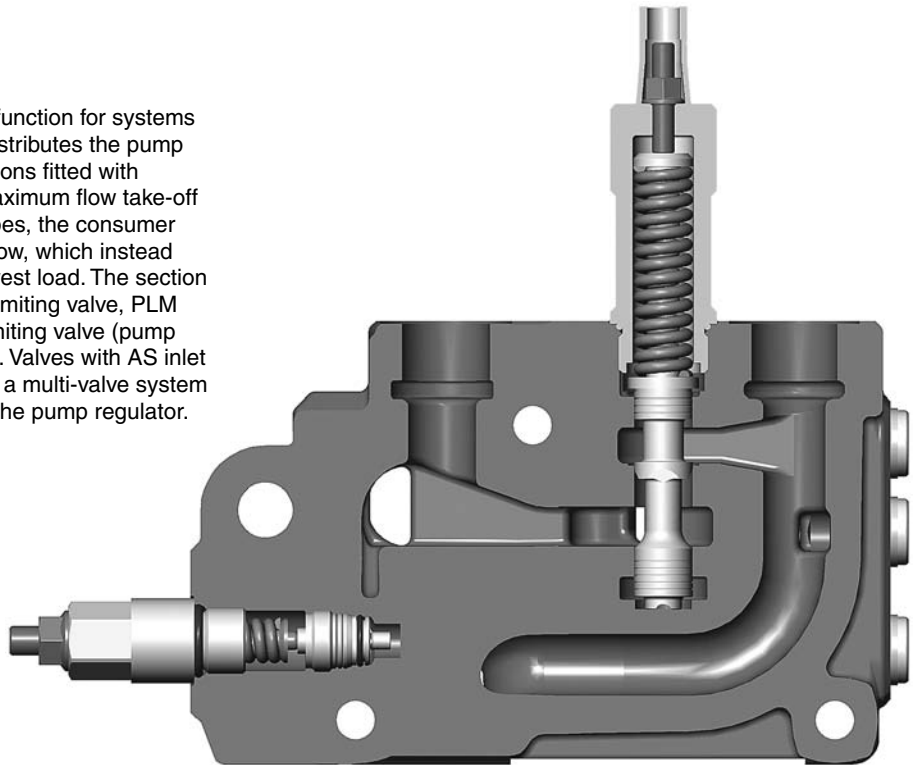

Inlet section AS

AS2 Inlet section for following valve in a flow distribution system. The load signal from this valve is connected to the preceding valve. Otherwise, the functionality is as for inlet section AS except that the section only contains a load pressure limiting valve, PLM [16].

IP Inlet plate without functions. Contains only connections for pump, tank and load signal.

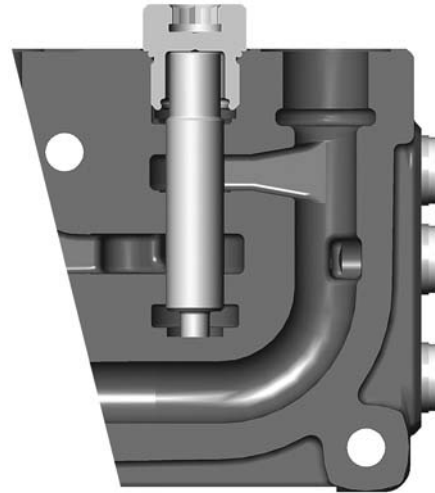

Inlet section AS2

CA/CL Combo inlet used as mid-inlet when L90 and K170/ K220 are assembled together. This works as an adapter plate between valves and replaces inlet sections from both valves. The combination inlet is available with the same functionality as the LS2, AS and AS2 inlets. It can also include pilot pressure supply and the counter pressure function, in which case it replaces the standard, US [30], and the simpler combined spool and end section, MU [30], can be used instead. The inlet is specified in the K170LS or K220LS valve specification, and the same code (CA/CL) must be entered for item 15.

For more information see the catalogue for K170LS or K220LS.

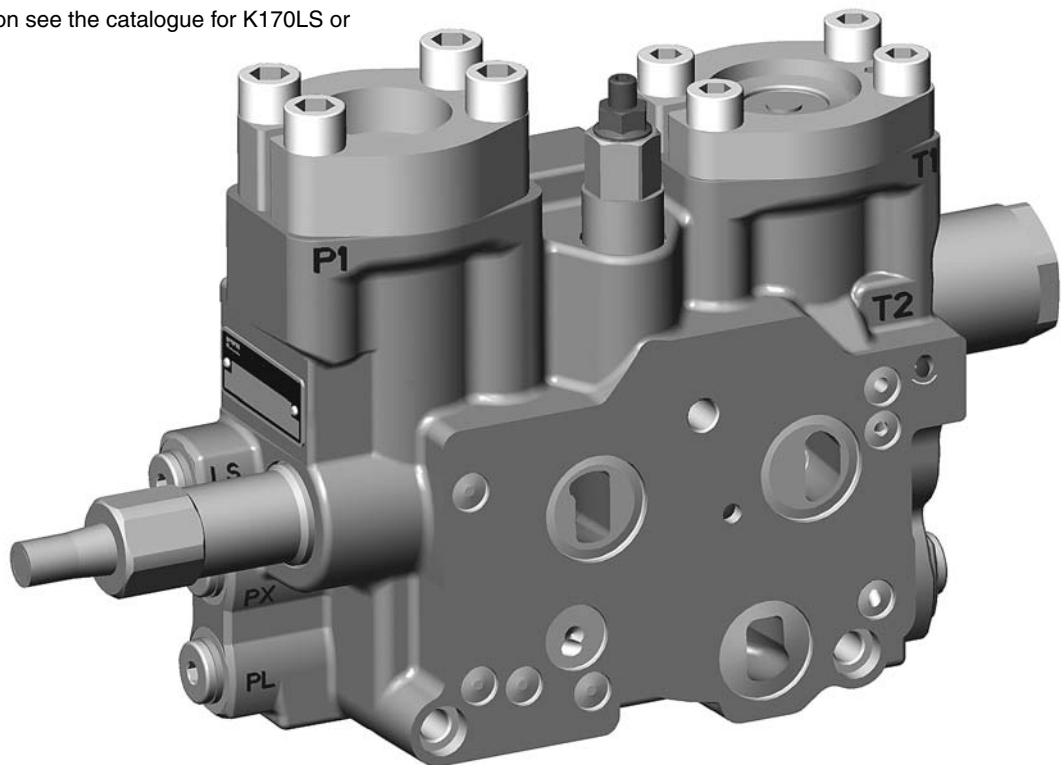

Combo-inlet CA

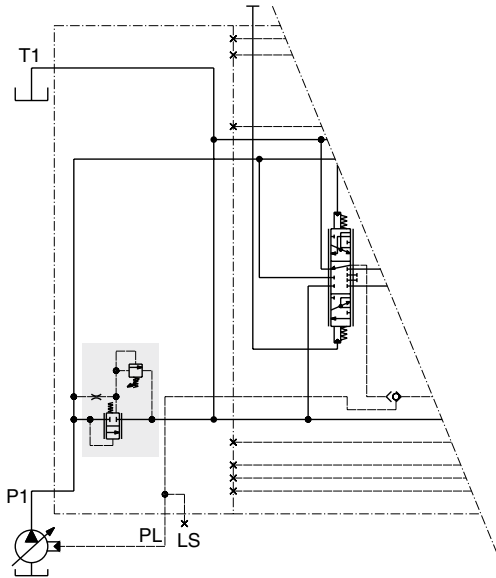

LS1 – Inlet section for systems with variable pump.

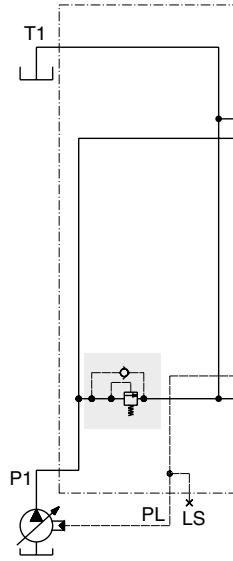

LS2 – Inlet section for systems with variable pump.

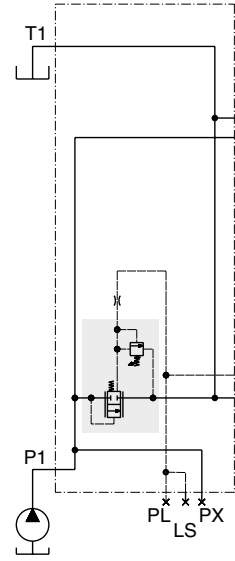

CFC – Inlet section for systems with fixed pump.

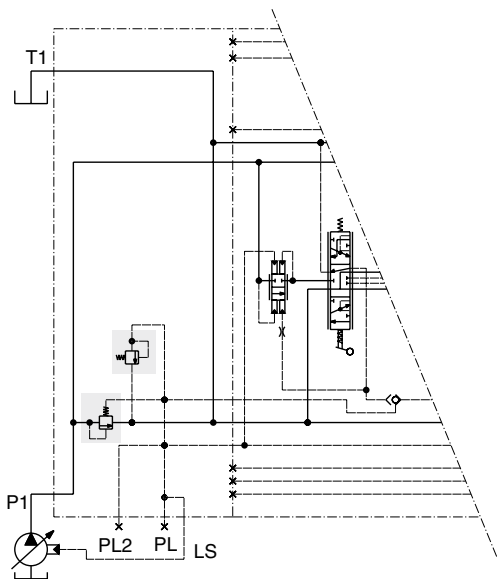

AS – Inlet section for flow-sharing valve.

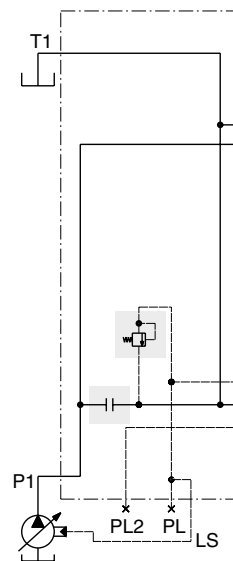

AS2 – Inlet section for secondary valve in flow-sharing system.

Pressure relief valve [16]

The inlet section is normally equipped with a pressure relief valve to protect the pump and valve from pressure peaks in the system when there are rapid changes in the load pressure.

PA1 Direct-acting pressure relief valve with very fast opening sequence and good pressure characteristic. The interchangeable cartridge is factory set. The cartridge has a make-up function, which means that oil is able to flow from the tank gallery to the pump gallery in the event of negative pressure in the pump circuit. The valve is intended for the LS2 inlet section [15]. For setting values, please see Pressure setting [17].

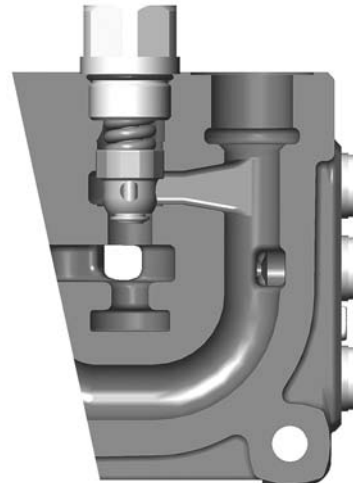

PA1 - Direct-acting pressure relief valve.

PLM Main relief valve in AS / AS2 [15] inlet section. Limits the load signal pressure that is sent to the pump.

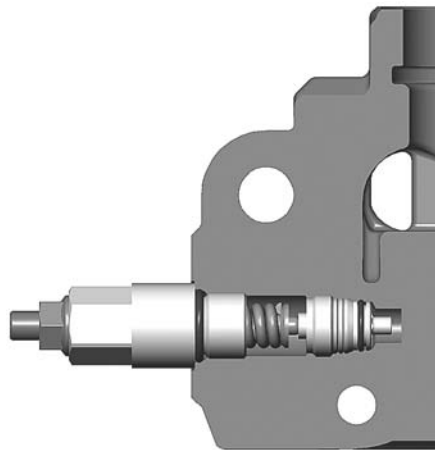

PLM – Pressure relief valve for inlet section AS and AS2.

PS Pilot-operated pressure relief valve with fast opening sequence and very low pressure override, which effectively prevents overloading of the hydraulic pump and the machine. The valve is adjustable and is delivered factory-set according to the value specified. The valve is intended for the CFC and LS1 inlet sections [15].

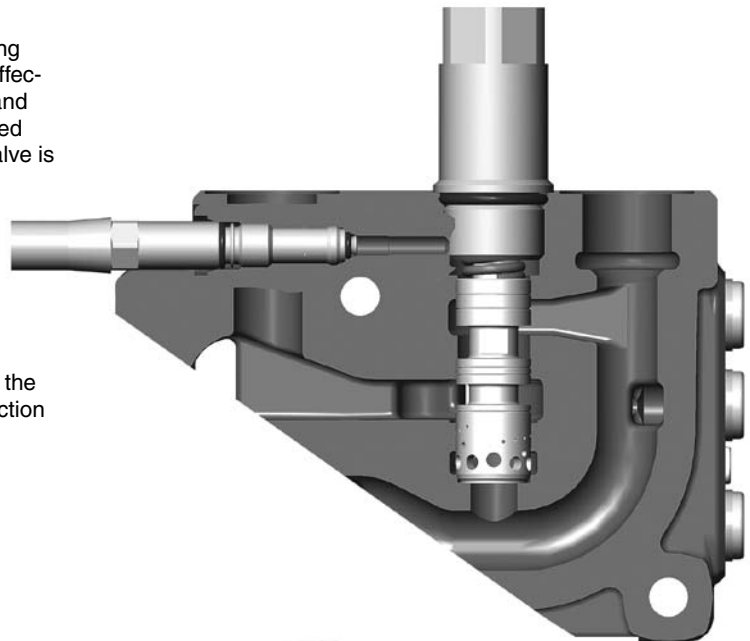

PS – Pilot-operated pressure relief valve for inlet section CFC and LS1.

Y Plug which can replace the pressure relief valve in the LS2 inlet section [15]. The Y-plug blocks the connection between the pump and tank completely.

/ Not machined for pressure relief valve.

Pressure setting [17]

Pressure setting for PA1 [16]

The direct-acting pressure relief valve, PA1, is delivered with a fixed setting. The following standard settings are available:
 Pressure setting in bar: 63, 80, 100, 125, 140, 160, 175, 190, 210, 230, 240, 250, 260, 280, 300 and 320.

Pressure setting for PS [16]

The pilot-operated pressure relief valve, PS, is adjustable from 50 to 320 bar. The valve can, however, be delivered with a fixed setting according to the value specified.

Δp (bar) Pressure relief characteristics

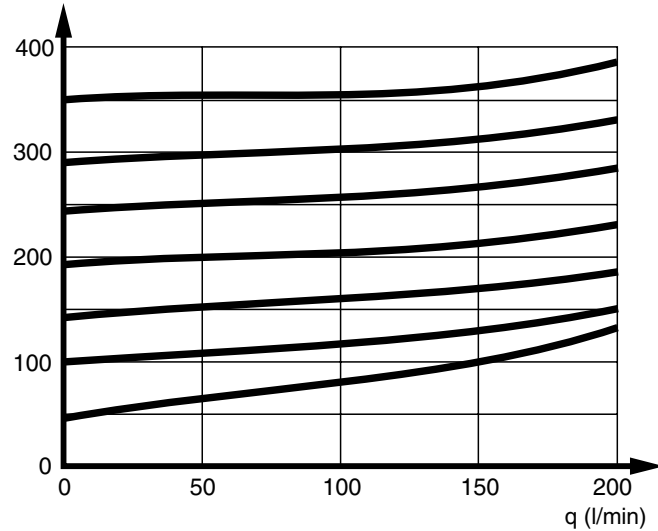

PA1 - Direct acting pressure relief valve.

Δp (bar) Pressure relief characteristics

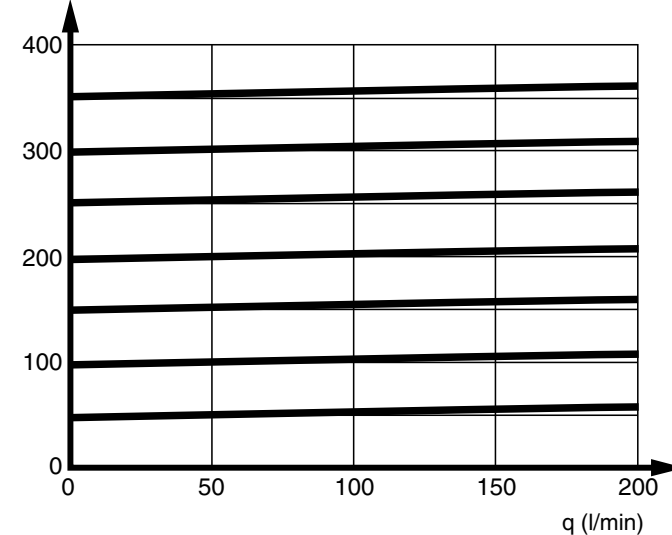

PS - Pilot-operated pressure relief valve.

Differential pressure limiter, PLS [18]

20-38 Function which maximize the pressure difference between the pump pressure and the load signal from the spool sections in inlet section AS [15]. The differential pressure must be set slightly higher in the inlet than in the pump regulator itself, approx. 5-8 bar.

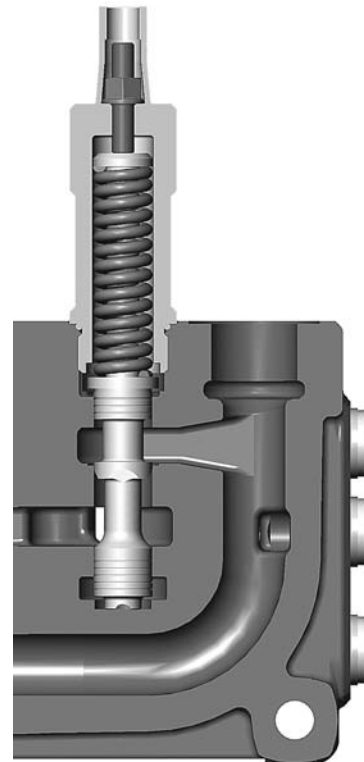

PLS - limiting function which maximise the differential pressure between the pump pressure and the load signal.

Load signal system [20]

The load-signal system consists of a series of shuttle valves, one for each spool section in the directional valve. The shuttle valves compare the load signals from all actuated spool sections and transmit the signal with the highest value to the PL connection in the inlet section. If the valve has a load-signal copying function, the signal is transmitted to a copy spool, which makes a copy of the signal and transmits it to the LS port.

If the load-signal chain is extended to a parallel-connected valve via the LSP port [31], then the highest load signal from the parallel-connected valve is included in the comparisons made by the load-signal chain in the first valve.

In the case of the CFC variant of the L90LS, i.e. the variant fed by a fixed pump, the highest load signal is transmitted to the bypass valve, which regulates the pressure in the pressure gallery to approx. 10 bar above the value of the signal.

KB Inlet section machined for copy spool but blocked. Provides option to install copy spool later. The load signal goes directly to the bypass in CFC systems, or to the PL connection in LS systems.

KS Inlet section with copy spool. The load signal acts on a copy spool, which sends a copied load signal to the LS connection. The copying system permits a certain consumption in the load-signal line to the pump regulator, without the load signal being influenced. This enables simpler system construction, with the possibility of installing logic systems in the LS circuit. Thanks to drainage in the pump LS regulator, the system gives better winter operating characteristics with faster response, since the oil in the LS circuit is always warm. Moreover, it prevents the tendency for the load to sink slightly at the beginning of the lifting phase.

Inlet sections of type LS2 [15] are normally equipped with copy spools.

/ Not machined for copy spool.

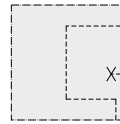

KB - Inlet section without copy spool.

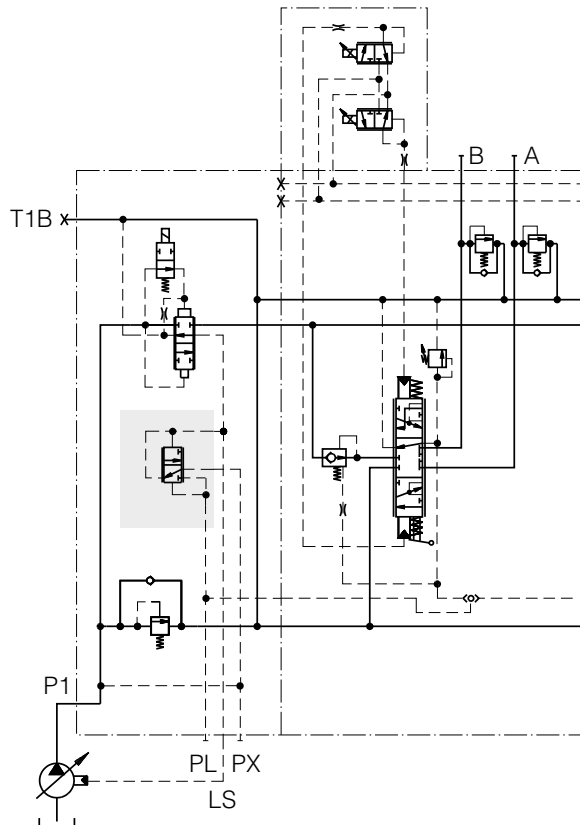

KS - Inlet section with copy spool.

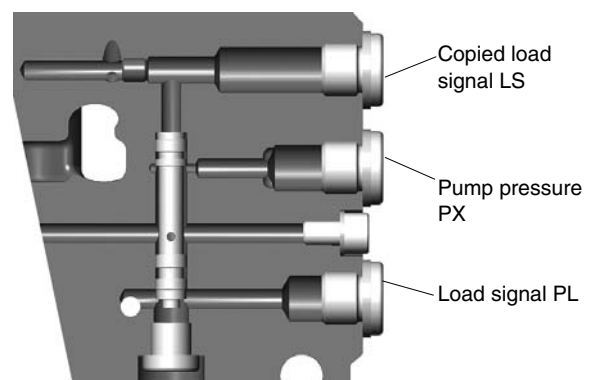

KS - Inlet section with copy spool.

Pump-unloading function [22]

If required, the valve can be equipped with a pump-unloading function in the inlet section. This enables machine manufacturers to equip their machines with an emergency-stop function to comply with the EC Machinery Directive. The function can be controlled either electrically or hydraulically.

(The inlet section is not normally machined to accommodate the pump-unloading function.)

BEN Electrically controlled pump-unloading function. When the current to the electromagnet is broken, the pump is blocked and the load signal drained to tank. In both LS and CFC systems, this means that the pressure gallery is shut off from the pump inlet and the pump is unloaded.

Connector AMP Junior-Timer type C
For ordering of connector, see page 35.

BX Hydraulically controlled pump-unloading function. When an external hydraulic signal with the same pressure as the pump is connected to the BX port, the pump is blocked and the load signal drained to tank. In both LS and CFC systems, this means that the pressure gallery is shut off from the pump inlet and the pump is unloaded.

Connection: G1/4 or 9/16-18 UNF-2B.

BB Inlet section machined for pump-unloading function.

/ Not machined for pump-unloading function.

Tank connection T1 [25]

T1 Tank connection T1 is open. Normal variant.

T1B Tank connection T1 is blocked.

T1X Used together with CFC [15] and MF counter pressure functions [33] only. Tank connection T1 in the inlet section is separated from the tank galleries in the spool sections. Pump oil that is not used flows via the bypass directly to tank via T1, while returning oil from the actuators flows to tank via the counter pressure valve in the end section and tank connection T3. Circuit, see page 9.

Pump connection P1 [26]

P1 Pump connection P1 is open. Normal variant.

P1B Pump connection P1 is plugged.

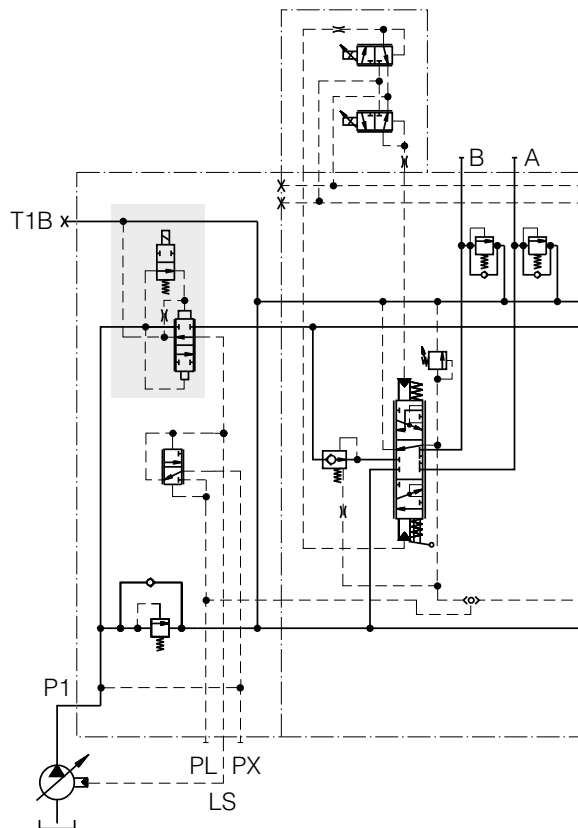

BEN - Electrically controlled pump-unloading function.

External connection of signal pressure from pump line

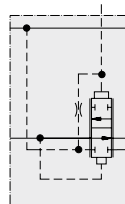

BX - Hydraulically controlled pump-unloading function.

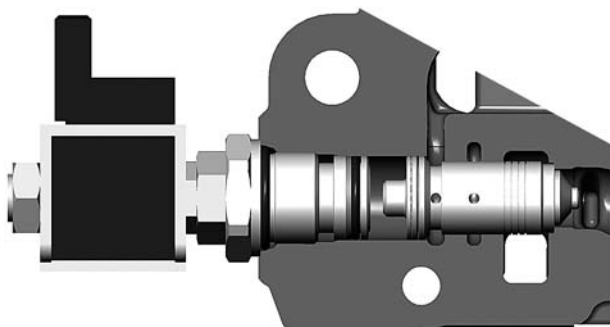

BEN - Electrically controlled pump-unloading function.

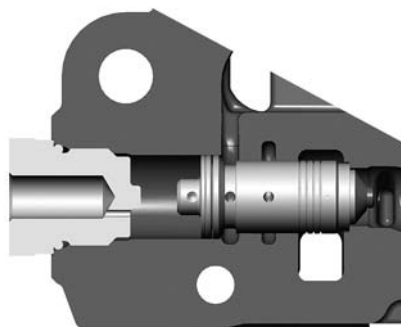

BX - Connection of signal pressure.

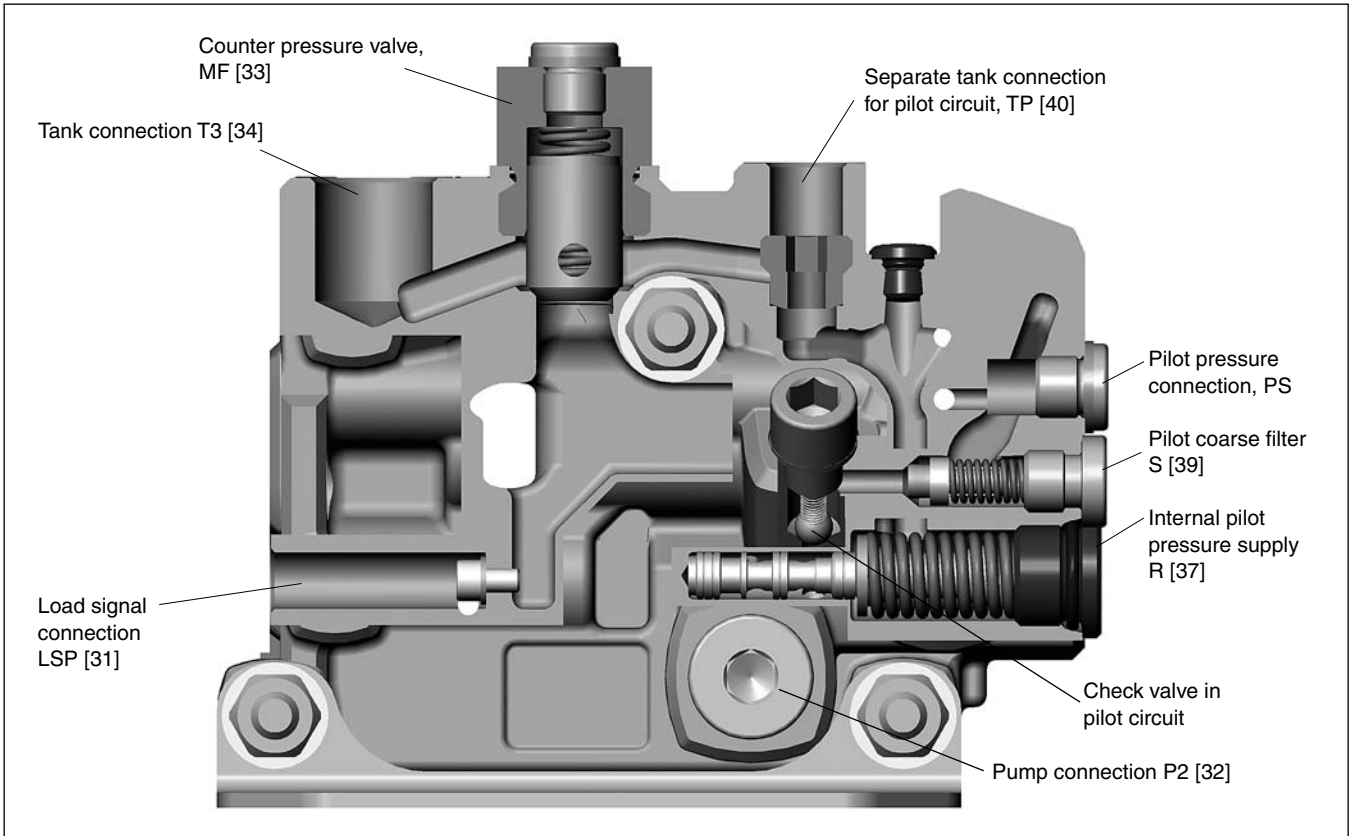

US End Section with pilot pressure supply, pilot filter, Counter pressure valve and separate tank connection for pilot circuit.

The end section can be equipped with a number of optional functions to customize it optimally for the given application. It can, for instance, be equipped with a pressure-reducing valve, R to supply internal pilot-pressure for hydraulic or electro-hydraulic spool actuators, and a fixed counter pressure valve, MF in the T2 port.

In the basic version of the end section, all connections are plugged.

As an alternative to the standard end-section, when internal pilot generation, R [37] and/or counter pressure valves, MF [33] are not needed, a combined spool-end section (MU) can be selected. MU [30], together with the combo-inlet section (CL/CA [15]), makes a very compact and cost effective solution.

End section [30]

US End section with the options pilot pressure supply and counter pressure function.

MU Combined spool and end section without counter pressure function, MF [33], and pilot pressure supply, R [37]. MU is useful in valves with open spool controllers, or if external pilot pressure supply is already available. The section is also useful together with combination inlets CA or CL [15].

Section MU is only available in nodular iron.

For more information about the spool section, see the selectable options later in the catalogue in the relevant sections.



Combined spool and end section MU.

LS connection [31]

LSP Port for connection of load signal from other valve open. This connection is used to receive the load signal from a parallel-connected valve.

LSPB Port for load signal from other valve plugged.

LSPX Only for end section MU [30]. Port for load signal plugged, with no possibility of converting to LSP version.

/ No LS connection.

Pump connection P2 [32]

P2 Alternative pump connection in rear face. The connection can, for example, be used to feed valves located to the rear, or for double feeding of the valve in applications where many machine functions with very high flow demands are operated simultaneously. Under certain provisions, the connection can also be used in situations when feeding from the rear face is the most suitable option in terms of available space. When feeding via P2, the pump-unloading function BEN [22] cannot be used.

P2B Alternative pump connection plugged.

/ No P2 connection.

Counter pressure valve / tank connection T2 [33]

T2 Alternative tank connection T2 open.

T2B Alternative tank connection T2 plugged.

MF Counter pressure valve factory set to give 5 bar counter pressure. Tank connection T1 must be plugged, T1B [25], and tank connection T3 [34] must be open.

If the system has a fixed pump, CFC [15], the option T1X [25] can be used to reduce the idling (no load) losses in the system. In this case, shunted oil in the inlet section cannot pass via the counter pressure valve

/ No T2 connection.

Tank connection T3 [34]

T3 Tank connection T3 is open.

T3B Tank connection T3 is plugged.

/ No T3 connection.

Internal-pilot pressure supply [37]

R Internal pilot-pressure supply is a valve function, built into the end section, which works as both a pressure regulator and a pressure relief valve in the pilot circuit. For safety reasons, the R-cartridge has also been equipped with a separate safety-valve function that prevents the maximum permissible reduced pressure from being exceeded. A check valve prevents pilot oil from leaking back to the pump, and therefore enables the pressure in the pilot circuit to be maintained in the event of a temporary fall in pump pressure, e.g. during a rapid lowering movement.

Pilot pressure for external use, e.g. for delivery to PCL4 remote control valves, can be tapped from the PS connection. Pressure setting: 35 bar.

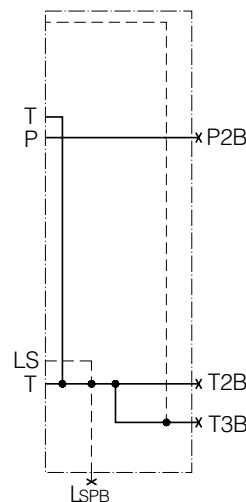

LSPB – LSP-port plugged and load signal internally connected to tank.

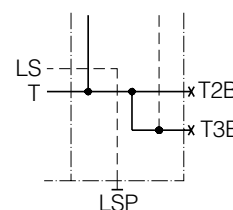

LSP – Port for connection of load signal from other valve is open.

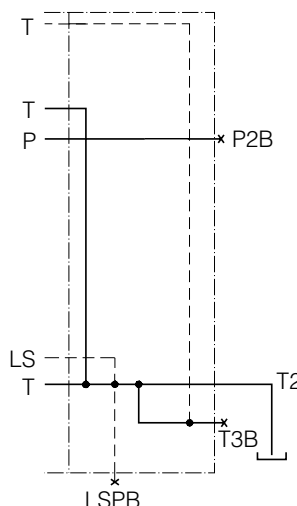

T2 – Without counter-pressure valve.

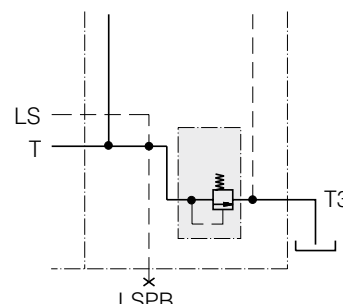

MF – Factory-set counter pressure valve.

R22 Same as R, but with 22 bar pressure setting.

R43 Same as R, but with 43 bar pressure setting.

PS Only for end section MU [30]. Connecting port for external pilot pressure supply machined and plugged in the end section face.

/ Valve without internal pilot-pressure supply.

Pilot filter [39]

- S** Coarse filter with bypass function in the internal pilot circuit. The filter protects the pilot circuit from dirt, especially during start-up of the system.
- YS** Adapter for connection of external filter for pilot oil. Enables the pilot circuit to be supplied with cleaner oil compared with the rest of the system.
- /** Not machined for pilot filter function

Tank connection for pilot circuit [40]

- TP** Separate tank connection for the pilot circuit is open. The connection to the main tank gallery of the directional valve is blocked. The function is intended for systems in which there is a risk of dynamic pressure fluctuations in the tank line, which cause fluctuations in the pilot circuit when there is a common tank line.
- TPB** The end section is machined to provide a separate tank connection for the pilot circuit, and plugged. The tank return of the pilot circuit is connected to the tank gallery of the directional valve.
- TPX** Only for end section MU [30]. The section is machined for external connection of the pilot circuit to the tank. The section has no internal connection between the tank return of the pilot circuit and the upper tank channels of the valve. The connection is plugged in the end section face.
- /** Not machined for TP connection

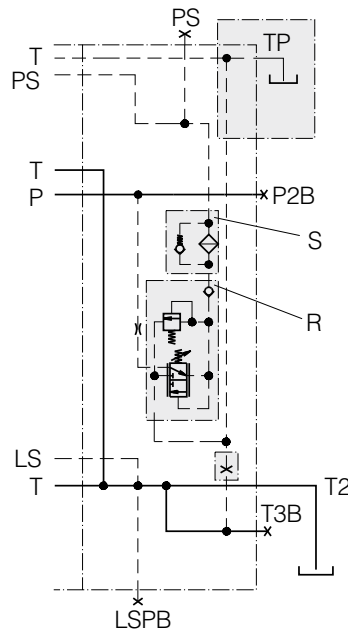

*R [37] internal pilot-pressure supply.
S [39] coarse filter with bypass function.
TP [40] end section machined to accommodate separate tank connection for pilot circuit.*

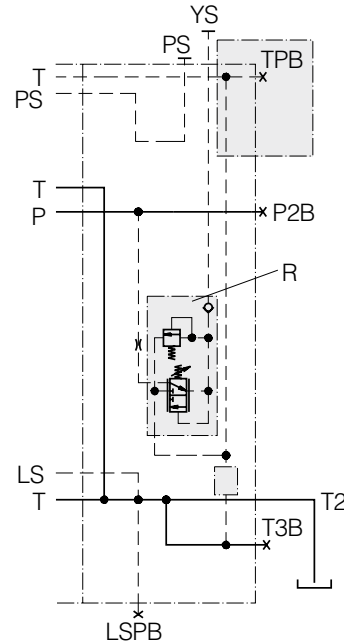

*R [37] internal pilot-pressure supply.
YS [39] adapter for connection of external pilot-pressure filter.
TPB [40] end section machined to accommodate separate tank connection for pilot circuit, and plugged.*

Spool Section

The L90LS is stackable and can be supplied in combinations of 1-12 spool sections. Each section can be equipped individually with a variety of optional functions, as well as different types of spool and spool-actuator. This enables optimum customization to the application and particular machine function in question.

Basic variants of spool section [47]

Spool sections are available in different variants depending on the choice of optional functions:

- OOO** Not machined for pressure compensator, load-hold check valve, feed reducer, port-relief or anti-cavitation valves.
- VOO** Section fitted with load-hold check valve, but not machined for port relief valves.
- TOO** Section fitted with pressure compensator, but not machined for port relief valves.
- TAO** Section fitted with pressure compensator and feed reduction in A-port, but not machined for port relief valves.
- TBO** Section fitted with pressure compensator and feed reduction in B-port, but not machined for port relief valves.
- TCO** Section fitted with pressure compensator and common feed reduction in A- and B-ports, but not machined for port relief valves.
- TTO** Section fitted with pressure compensator and individual feed reduction in A- and B-ports, but not machined for port relief valves.
- **T** All of the section variants above are available in versions that are machined for, and can be fitted with, port relief and/or anti-cavitation valves in service ports A and B. In such cases, the letter T is given in the third position in the product designation, e.g. OOT, VOT, TOT, TAT, TBT, TCT and TTT. For further information, see Port relief and/or anti-cavitation valves [76].
- MU** Combined spool and end section. Shorter total valve length. For further information, see end section [30].

V** and T** have the same machining and can be converted easily from one variant to another at any time. However, the machining for *O*, *A*, *B*, *C* and *T* sections are different.

For further information, see also "Pressure compensator / load-hold check valve [66]" and "Feed reducing valve [75]".

Material of spool section [48]

- G** Spool section in grey iron. Can be used up to a pressure setting of 260 bar in the pump connection and 280 bar in the shock valves in motor ports.
- S** Spool section in nodular iron.

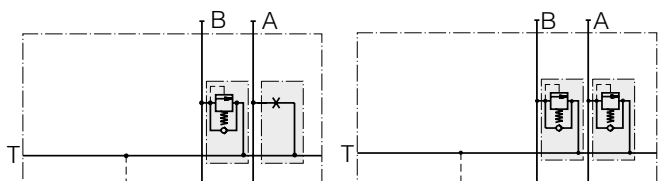

Variant **T prepared for port-relief and/or anti-cavitation valves in service-ports A and B.

Above left: section with Y-plug in A-port and combined port-relief and anti-cavitation valve in B-port.

Above right: section with combined port-relief and anti-cavitation valves in both A and B ports.

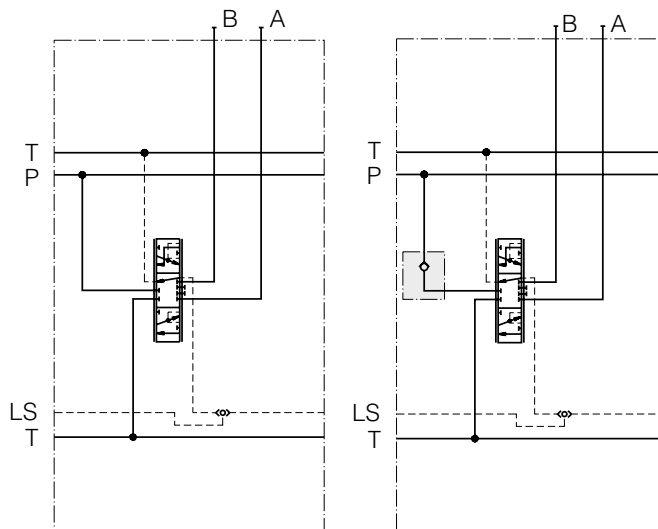

Variant OOO.

Variant VOO.

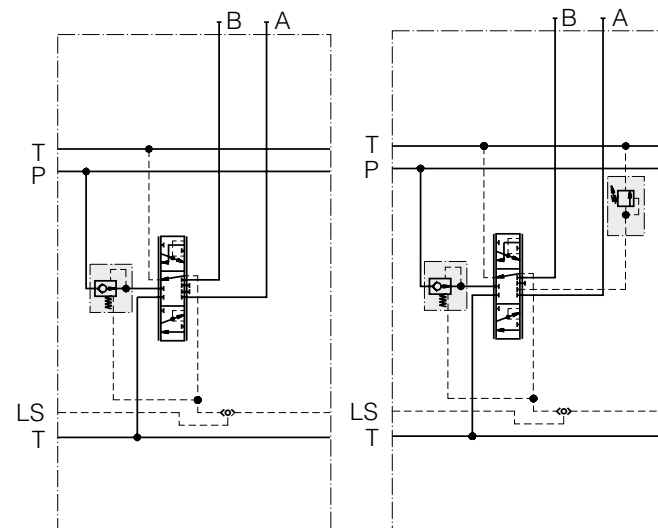

Variant TOO.

Variant TAO.

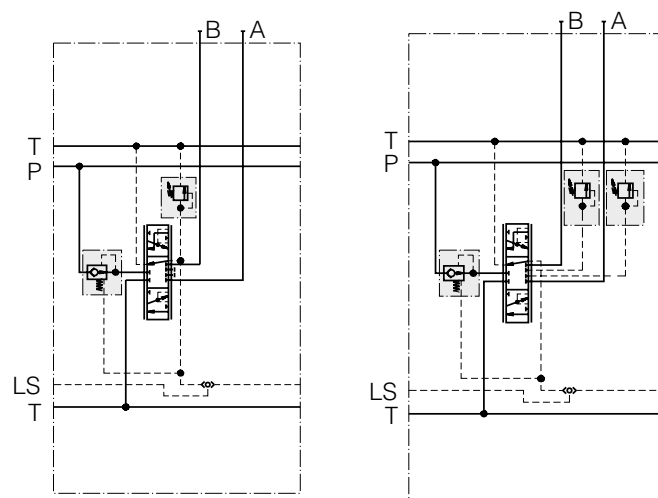

Variant TCO.

Variant TTO.

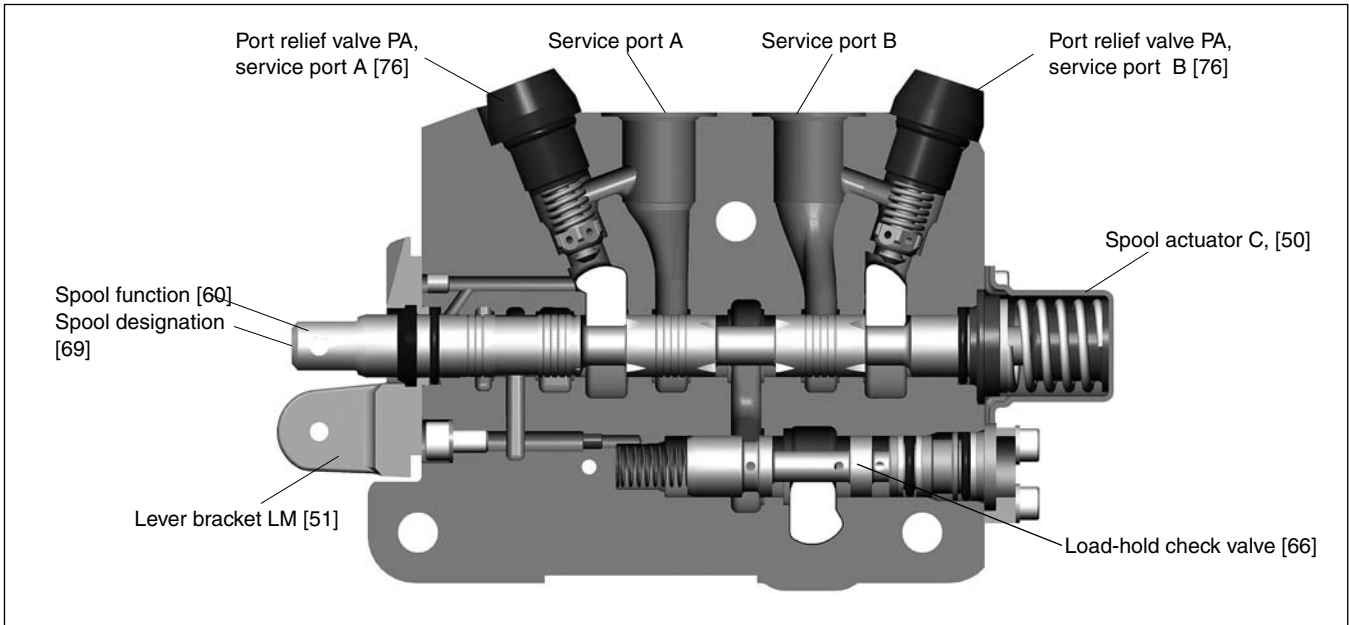

Spool actuators of both the open and enclosed type can be used on the L90LS. Open spool-actuators, in which the spool-end is exposed, are simpler and cheaper. They are intended for use in systems where low capital cost is a priority. They can be operated directly by means of linear levers or can be connected to remote controls by means of wires.

With enclosed spool-actuators, the spool-ends are totally enclosed in oil-filled caps. Enclosed spool actuators are intended primarily for hydraulic and electro-hydraulic remote control, but can also be the preferred choice for direct control in aggressive environments.

Different versions of spool actuator are available. Details can be found below.

Spool actuators [50]

Directly operated actuators, with open spool-end

C Spring-centred spool actuator
 Steplessly operable with spring-return to neutral.
 Spring force in neutral: 60 N
 Spring force when fully actuated: 130 N

B3 Three-position spool actuator
 Equipped with 3-position mechanical detent that gives 3 fixed positions: neutral and fully actuated in either direction. Spool remains in selected position and must be moved deliberately from one position to another.
 Force needed on spool to overcome detent: approx. 160 N

FD Friction-detented spool actuator
 Lever remains at selected stepless position. A force index indicates when the lever is in neutral.

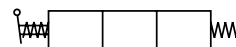

C

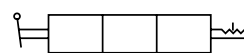
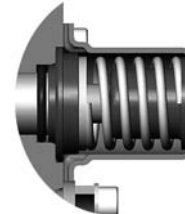

B3

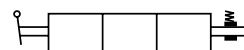
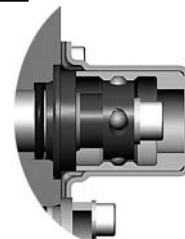

FD

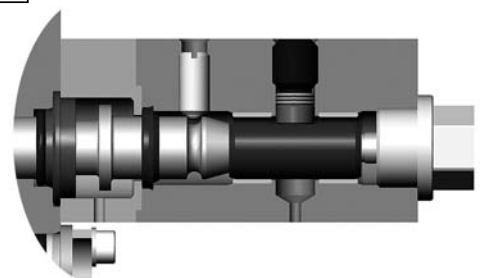

ON/OFF remote-controlled actuators, with open spool-end and facility for manual control

ACE Electro-pneumatic spool actuator, ON/OFF

Spring-centred. Can be fitted with supplementary local lever (optional) for direct, stepless actuation of spool.

Supply pressure: min. 4 bar
max. 10 bar

Spring force in neutral: 95 N

Spring force when spool fully actuated: 160 N

Solenoid: 12 V DC 0.85 A
24 V DC 0.42 A

Voltage tolerance: ±20%

Connections: G 1/8 or NPTF 1/8-27.

Connector type B EN175301-803 (DIN43650)/ISO6952.

For ordering of connector, see page 35.

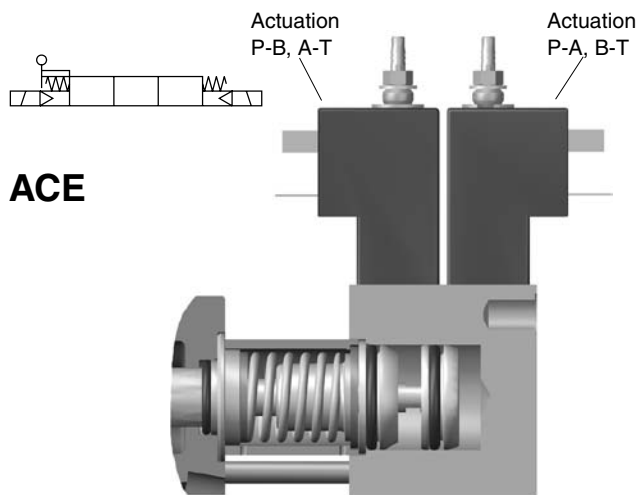

ACE

ACEF Electro-pneumatic spool actuator, ON/OFF

ACEF is identical to the ACE, except that ACEF has a common pressure gallery for primary air.

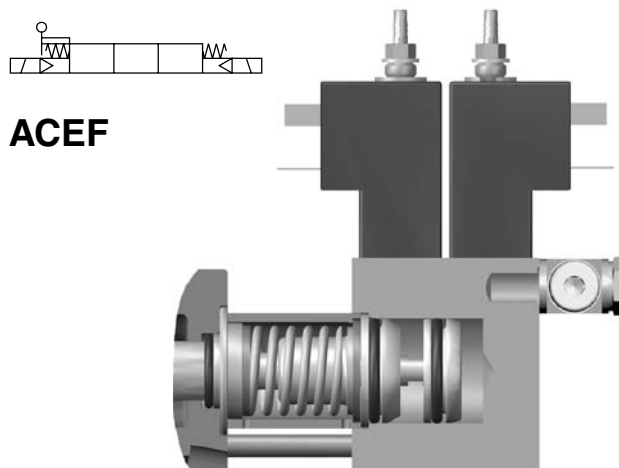

ACEF

Remote-controlled actuators, proportional spool actuators with open spool-end and facility for manual control

ACP Pneumatic proportional spool-actuator ACP can be fitted with supplementary local lever (optional) for direct, stepless actuation of spool. The ACP is best controlled by means of our **VP04** remote-control valve (see separate brochure).

Breakaway pressure*: 2 bar
Final pressure*: 7 bar
max. 10 bar

Connection thread: G 1/8 or NPTF 1/8-27.

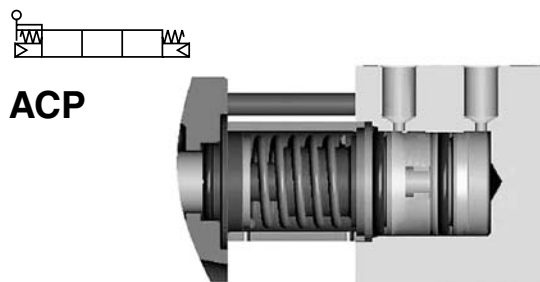

ACP

Lever brackets [51]

LM For spool actuators with open spool-end.

LU Spool-sealing cover without lever bracket for spool actuators with open spool-end.

* The breakaway pressure is the pressure needed for the directional valve to open the connection "pump to service port". The final pressure is the lowest pressure needed to effect full actuation of a spool in the directional valve. This data must be taken into consideration when choosing control units, since the opening pressure of the control unit must be lower than the breakaway pressure of the spool actuator in order to avoid jerky starting and stopping. However, the control unit's final pressure must be higher than the final pressure of the directional valve in order to ensure that the spools can be fully actuated.

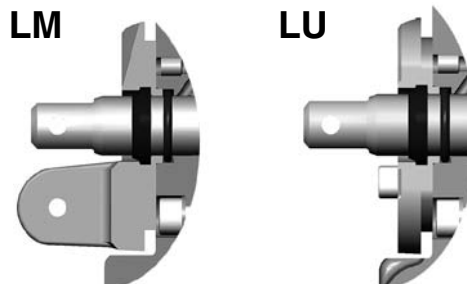

Spool in (→) activate P-B, A-T
Spool out (←) activate P-A, B-T

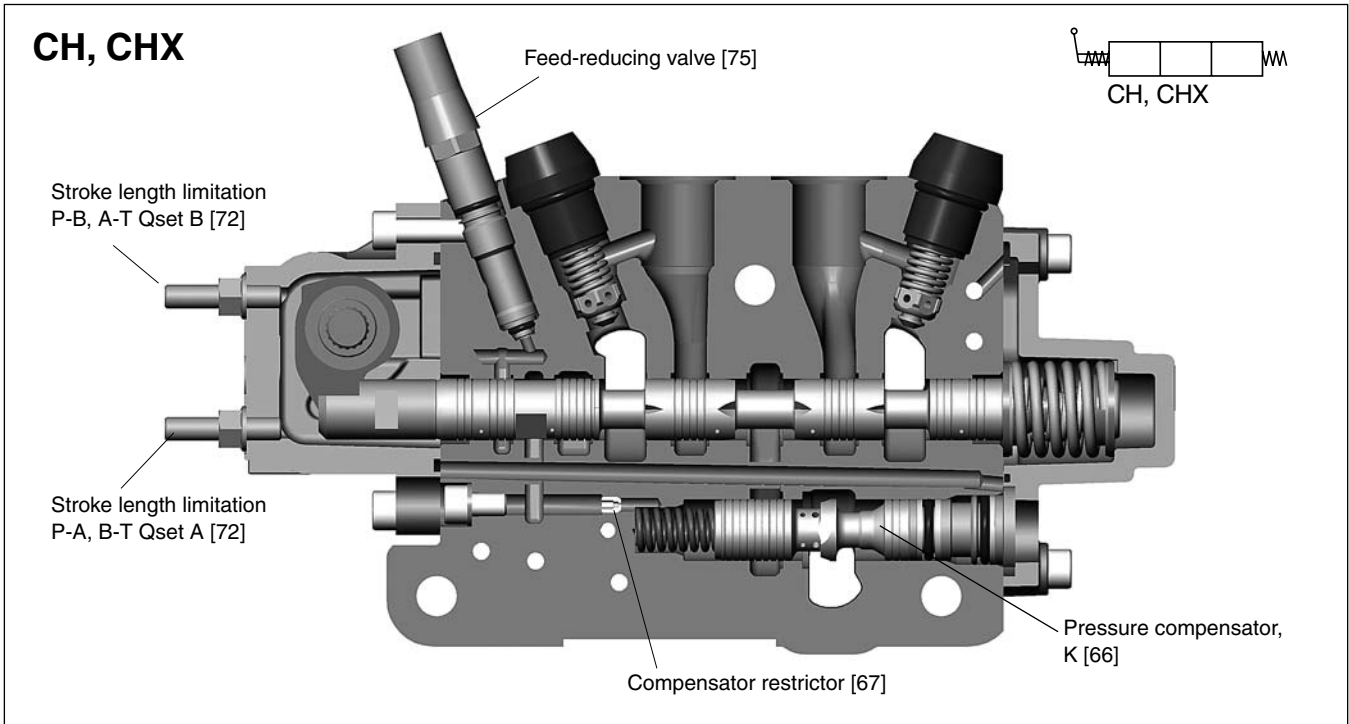

Directly operated actuators with enclosed spool-ends

CH Spring-centred spool actuator
 Has enclosed spool-ends for use in aggressive environments.
 Steplessly operable with spring-return to neutral.
 Spring force in neutral: 70 N
 Spring force with spool fully actuated: 140 N

CHX Spring-centred spool actuator
 Same as CH, but with stronger springs to compensate for friction in external linkage arms etc.
 Spring force in neutral: 85 N
 Spring force with spool fully actuated: 250 N

CHB3 Three-position spool actuator
 Equipped with 3-position mechanical detent that gives 3 fixed positions: neutral and fully actuated in either direction. Spool remains in selected position and must be moved deliberately from one position to another.
 Force needed on spool to overcome detent: approx. 160 N

CHB3

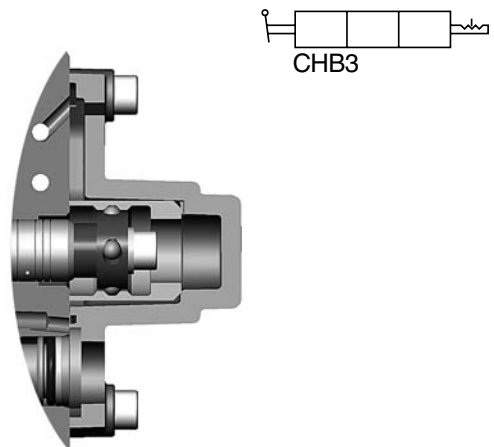

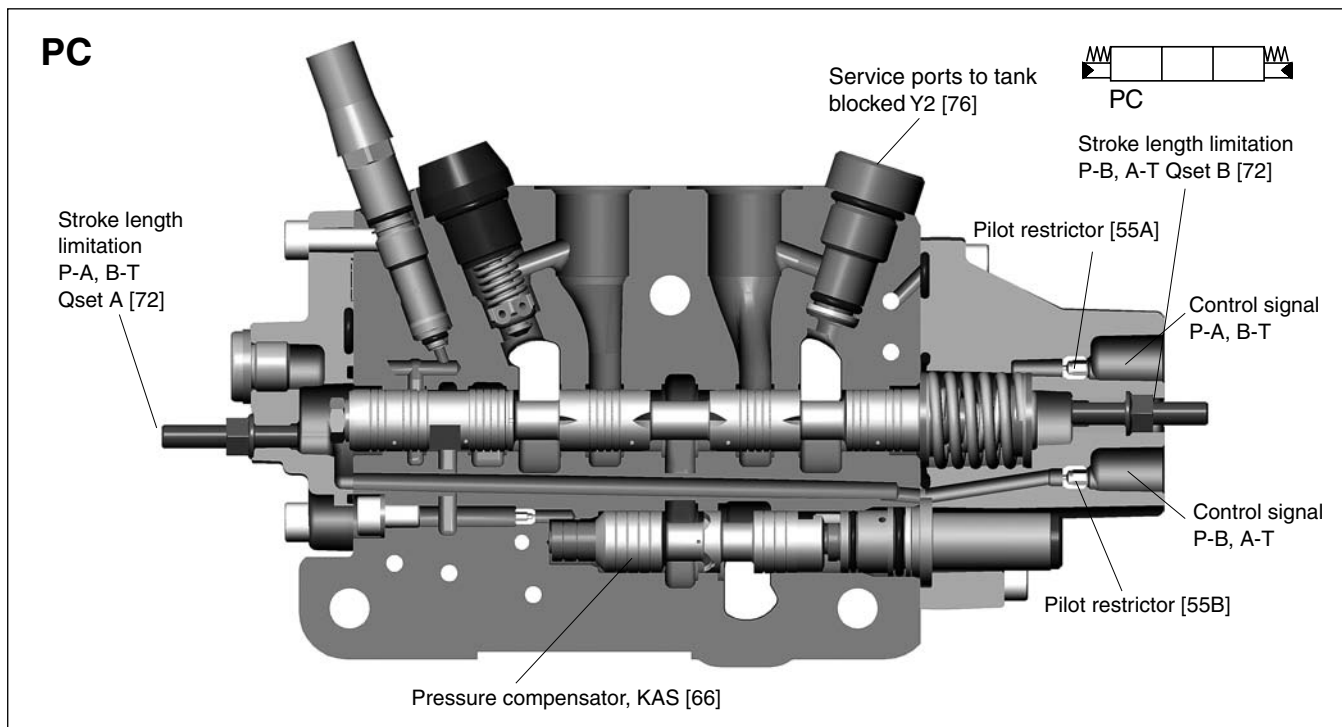

Proportionally remote-controlled actuators, with enclosed spool-ends and facility for manual control

PC Hydraulic spool-actuator

PCH Hydraulic spool-actuator with facility for supplementary local lever for direct control

The PC and PCH are proportional, hydraulically controlled spool actuators with spring-centring to neutral. They are intended to be controlled by the **PCL4** remote-control valve. When determining a suitable control pressure for the PCL4, bear in mind that its breakaway pressure should be approx. 0,5 bar lower than that of the directional valve in order to ensure gentle starting and stopping. The pilot pressure for the PCL4 can be tapped from the internal pilot-pressure supply in the end section of the directional valve, via the PS connection.

Breakaway pressure*:	5.5 bar
Final pressure*:	15.0 bar
Permissible pressure in pilot cap:	max. 35 bar
Connections:	G ¼ or 9/16-18 UNF

*
The breakaway pressure is the pressure needed for the directional valve to open the connection "pump to service port". The final pressure is the lowest pressure needed to effect full actuation of a spool in the directional valve. This data must be taken into consideration when choosing control units, since the opening pressure of the control unit must be lower than the breakaway pressure of the spool actuator in order to avoid jerky starting and stopping. However, the control unit's final pressure must be higher than the final pressure of the directional valve in order to ensure that the spools can be fully actuated.

PCH

Stroke length limitation P-B, A-T Qset B [72]

Stroke length limitation P-A, B-T Qset A [72]

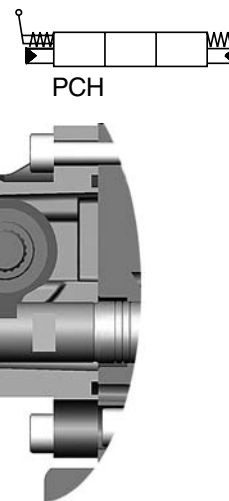

See also separate catalogue for PCL4.

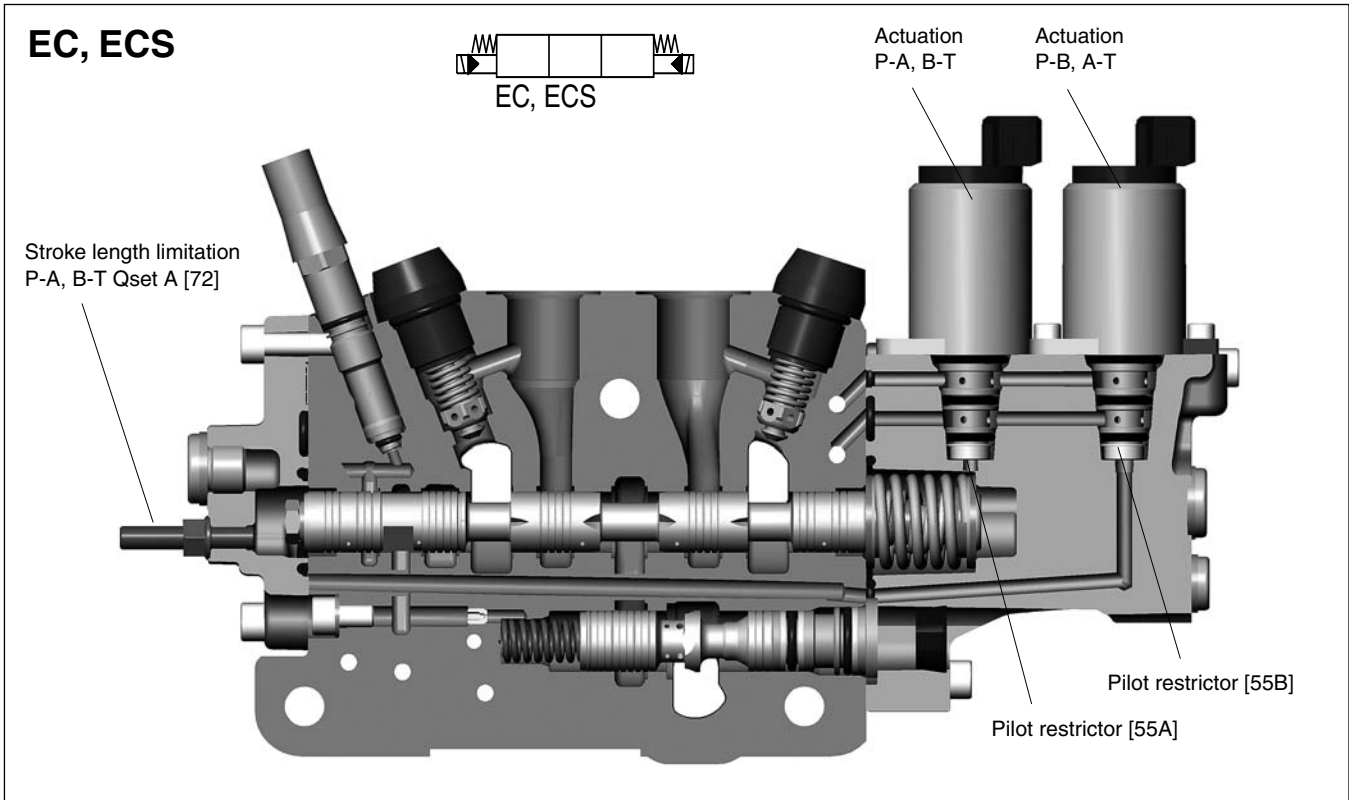

Proportionally remote-controlled actuators, with enclosed spool-ends

EC/ECS Electro-hydraulic spool actuator

The EC/ECS are proportional, electro-hydraulically controlled spool actuators with spring centering to neutral. They are intended to be controlled remotely by the IQAN control systems. Pilot-pressure oil is led to the spool actuators through internal ducts in the directional valve. This means that only the cable connectors from the control system to the pilot solenoid valve needs to be connected externally.

Control current for 12 V

Breakaway*	min. 550 mA
Fully actuated	max. 980 mA

Control current for 24 V

Breakaway*	min. 260 mA
Fully actuated	max. 510 mA

The control current must be regulated for temperature compensation and with ripple to minimise hysteresis. Measuring connections: G1/4 or 9/16-18 UNF

EC as ECS but with manual over-ride and air-bleed screw in the pilot solenoid valve.

* The breakaway current refers to the current needed for the directional valve to open the connection "pump to service port". The final current is the lowest current needed to effect full actuation of a spool in the directional valve. This data must be taken into consideration when choosing control units, since the opening current of the control unit must be lower than the breakaway current of the spool actuator in order to avoid jerky starting and stopping. However, the control unit's final current must be higher than the final current of the directional valve in order to ensure that the spools can be fully actuated.

Connector Type [56]

The connector of the solenoid is of type:

- A** AMP Junior-Timer type C.
- D** Deutsch type DT04-2P. Mates with DT06-2S Plugs.

The connector must be ordered separately.

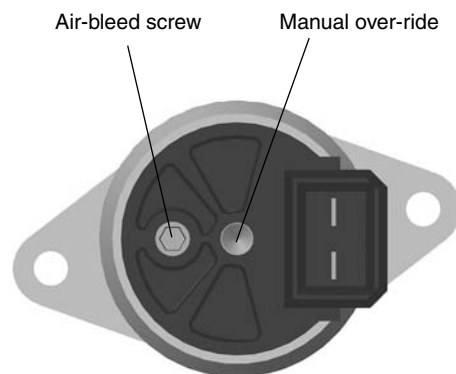

EC pilot solenoid valve with manual over-ride and air-bleed screw.

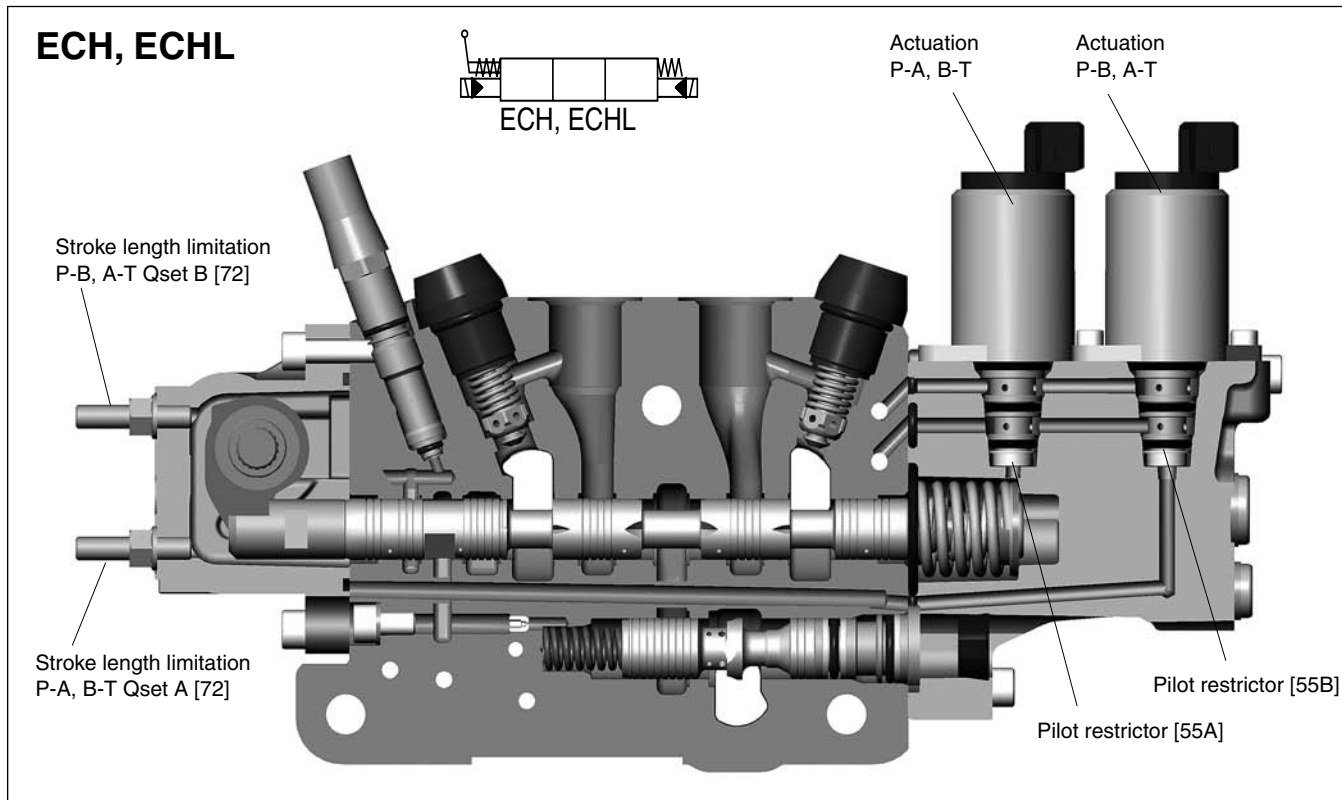

Proportionally remote-controlled actuators, with enclosed spool-ends and facility for manual control

ECH Electro-hydraulic spool actuator with facility for supplementary local lever for direct control
 The ECH spool actuator can be operated directly and steplessly by a supplementary local lever (optional).

Spring force in neutral 60 N
 Spring force with spool fully actuated 350 N

Other data as for ECS to the left.

ECHL Same as ECH, but with weaker centering spring. Suitable for use, e. g. when spool actuator is mainly intended to be operated directly.

Spring force in neutral 85 N
 Spring force with spool fully actuated 250 N

Control current for 12 V

Breakaway* min. 550 mA
 Fully actuated max. 820 mA

Control current for 24V

Breakaway* min. 260 mA
 Fully actuated max. 440 mA

Other data as for ECH above.

*

The breakaway current refers to the current needed for the directional valve to open the connection "pump to service port". The final current is the lowest current needed to effect full actuation of a spool in the directional valve. This data must be taken into consideration when choosing control units, since the opening current of the control unit must be lower than the breakaway current of the spool actuator in order to avoid jerky starting and stopping. However, the control unit's final current must be higher than the final current of the directional valve in order to ensure that the spools can be fully actuated.

Connector Type [56]

The connector of the solenoid is of type:

- A** AMP Junior-Timer type C.
- D** Deutsch type DT04-2P. Mates with DT06-2S Plugs.

The connector must be ordered separately.

Lever bracket [51]

L1 Lever-bracket for directly operated spool actuators with enclosed spool-ends, e.g. CH, and for remote-controlled spool actuators that have facility for supplementary local lever for direct control, e.g. ECH.

In addition to the normal lever-attachment angle, L1, the lever bracket is available in 8 other angles, designated L0 to L8 (see figure opposite). In the L4 variant, for instance, the lever is mounted parallel with the spool.

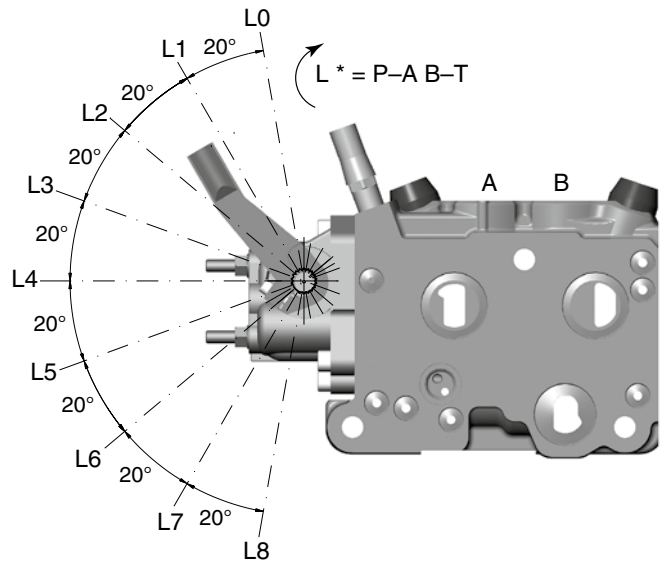

Lever brackets L can be given different attachment angles.

Pilot restrictor [55 A, B]

To give gentle control characteristics, remote-controlled spool actuators with enclosed spool-ends are fitted with pilot restrictors, which can be chosen individually for each service port. The restrictor gives a kind of ramp function.

Restrictors from 0.45 to 2.0 mm available.
 As standard 0,8 mm is recommended.

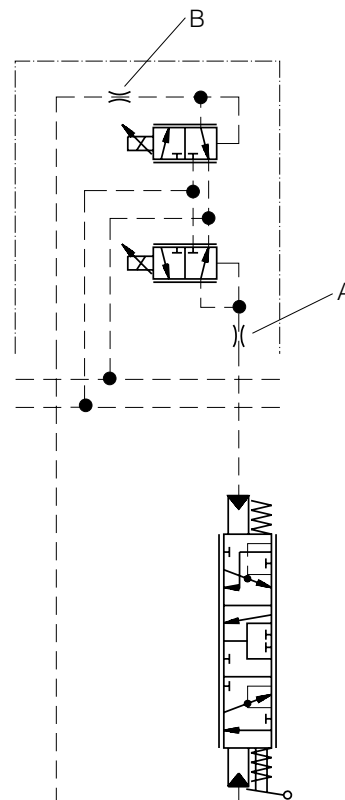

Pilot restrictor.

The spool is the most important link between the operator's actuation of a control lever and the behaviour of the corresponding machine function. The designs of our spools are therefore customized to meet the operating criteria of each individual machine function as accurately as possible. Spools are designed with the aid of a computerized specification system, which takes all factors into account.

Spool function [60]

There are many spool variants: D, EA, EB, M, CA, Dm, Da and Db, which are customized for different flows, load conditions and actuator area ratios. The spools are also available with different degrees of force feedback from the A- and/or B-side [64 A/B].

- D** Double-acting spool for, e.g. double-acting cylinder. Blocked in the neutral position.
- EA** Single-acting spool for, e.g. single-acting cylinder. Blocked in the neutral position. Service port B blocked.
- EB** Single-acting spool for, e.g. single-acting cylinder. Blocked in the neutral position. Service port A blocked.
- M** Double-acting spool for, e.g. hydraulic motor. Float position function in neutral position.
- CA** Regenerative spool for saving oil from the pump. The large side of the cylinder is connected to the A-port. Oil from the B port is passed to the A port and not to the tank when P is connected to A.
- Dm** Double-acting spool with drainage A to T and B to T, which prevents pressure build-up in the neutral position. The spool is used as a double-acting spool in combination with, e.g. an overcentre valve.
- Da** Double-acting spool with drainage A to T, which prevents pressure build-up in the A-port in the neutral position. The spool is used as a double-acting spool in combination with, e.g. an overcentre valve.
- Db** Double-acting spool with drainage B to T, which prevents pressure build-up in the B-port in the neutral position. The spool is used as a double-acting spool in combination with, e.g. an over-centre valve.

Flow requirements [61 A, B]

There is a wide range of function optimized spool for the L90LS with nominal flows of up to 90 l/min per spool-section when the sections are equipped with individual pressure-compensators.

Without individual pressure-compensators, flows up to 125 l/min per spool section are obtainable, depending on the adjusted differential between the load-signal pressure and the pump pressure.

On the basis of the desired flows to the A and B ports entered in the ordering documentation, our computerized valve-specification system selects a spool to give at least the specified flow, at the same time taking all other parameters into account.

The maximum flow is then set by limiting the spool stroke by means of adjustment screws on the spool actuators or, in the case of electro-hydraulic remote control, by tuning the electronics.

See "Flow settings [72]" for details on factory-set maximum flows.

Spool symbols

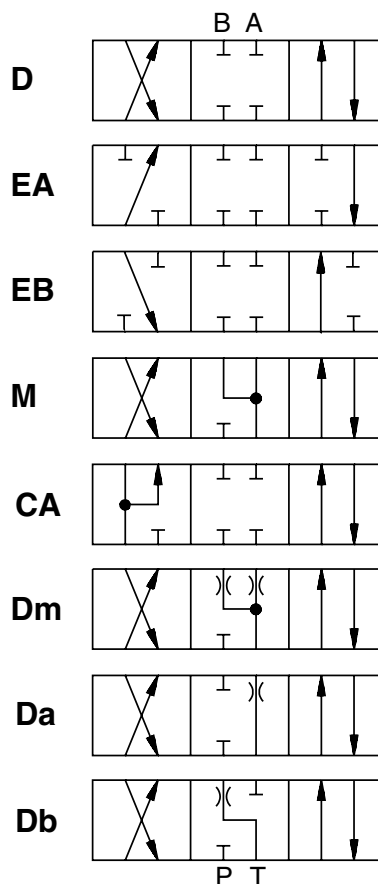

q (l/min) Flow rate in motor connection

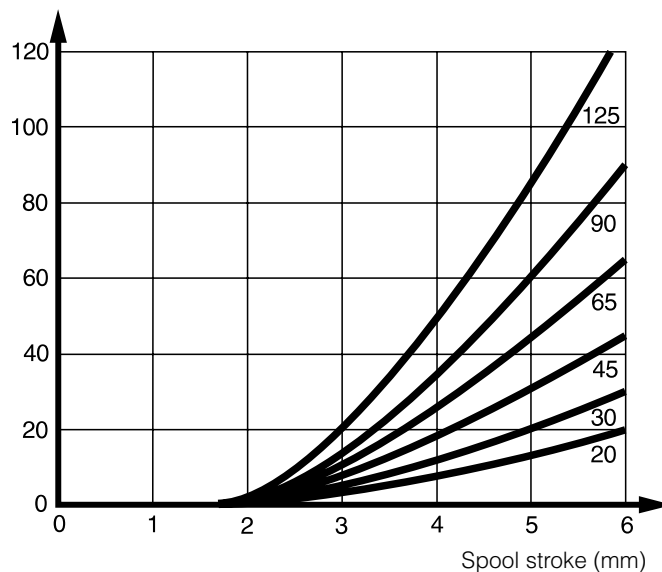

Typical curves showing flow as a function of spool stroke.

Area ratios [62]

The area ratio for a spool section is calculated by dividing the cylinder area that is connected to the B-port by the area connected to the A-port. When the large side of the cylinder is connected to the A-port, the area ratio is less than 1. The area ratio for a motor is 1.

Load characteristics [63]

The characteristics of the lift load can be specified according to five typical cases. This information is entered so that the spool can be customized optimally for the intended application.

- LAB** Lift load can alternate between A-port and B-port.
- LA** Lift load normally on A-port only.
- LB** Lift load normally on B-port only.
- LN** No or low lift-load on A- and B-ports.
- S** Slewing function.

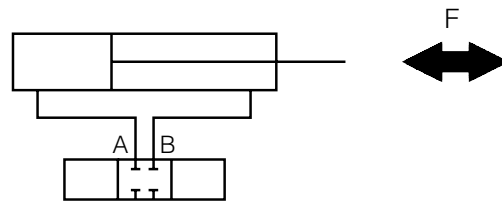

LAB - Lift load can change between the A- and B-port.

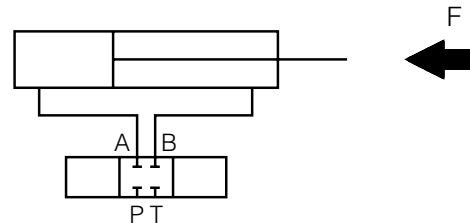

LA - Lift load normally on A-port only.

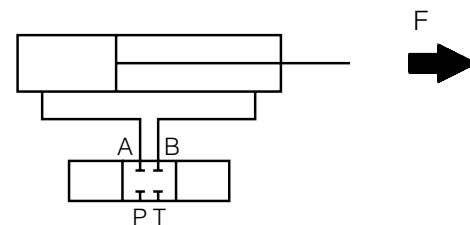

LB - Lift load normally on B-port only.

Force feedback [64 A, B]

The L90LS can be furnished with a force-feedback function to give operators of the LS system the same positive sense of force-control obtained with constant-flow (CFO) systems. This makes it easier for the operator to avoid damaging the machine in applications such as digging, since he is able to sense increasing resistance or outright obstacles to the movement of a machine function.

Force feedback also gives a kind of ramp function that results in more gentle transition between rapid changes in the speed of a machine movement. This in turn has a stabilizing effect on the hydraulic system and results in smoother operation of the machine. Both characteristics are important, especially for functions like slewing movements. In addition to increasing the efficiency of the machine, they also minimize wear.

The A and B ports individually can be given any one of three different levels of force feedback. The higher the level, the greater the reduction in speed for a given lever stroke as resistance rises. This means that the operator must move the lever further if he wishes to maintain the same speed of movement with rising resistance.

- /** No force feedback
- FN** Normal level of force feedback
- FH** High level of force feedback
- FL** Low level of force feedback

The force feedback function is not available for directly operated valves.

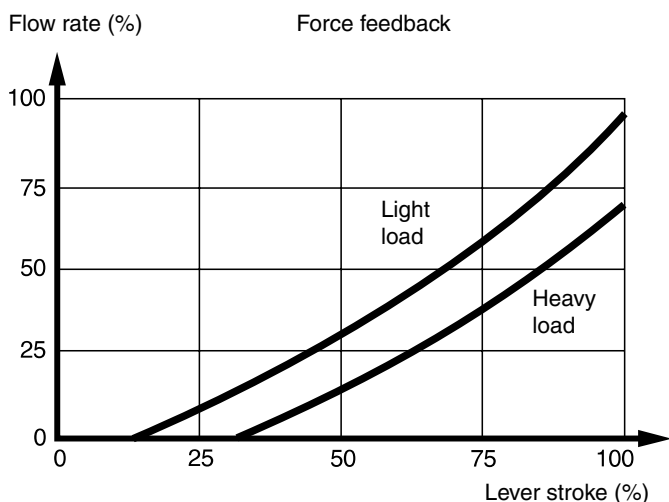

Pressure compensator / load-hold check valve [66]

When there are demands for very good simultaneous-operating characteristics or intensive, multi-section operability and responsiveness, individual spool-sections in the L90LS can be equipped with integral pressure-compensators. Sections so equipped are not then influenced by other simultaneously-operated machine functions, regardless of the variations in loads, provided there is sufficient pump capacity.

Responding to the instantaneous value of the load signal, the pressure compensator regulates continuously the flow through the spool to maintain a constant pressure-differential between the pump and service-port sides of the spool. This results in a constant flow to the consumer for a given lever stroke, regardless of the load pressure or any activity in other spool sections.

The compensator is available in a standard design with code K, as well as KL with a lower setting, and KH and KX with a higher setting. KL produces a flow corresponding to 85% of the standard flow, and is primarily intended for adjusting the flow requirements of the section. KH and KX produce flows corresponding to 120% and 150% of the standard flow respectively.

The pressure compensators are fast and responsive, and come with an integrated load-hold check-valve function. If necessary, spool sections with pressure compensators can also be equipped with feed-reducing valves in the service ports to regulate the delivery pressure to the consumer to the desired level.

(V** and T** spool-sections [47] have the same machining and can be converted easily to accommodate feed-reducing and port-relief valves according to O**, V** or T**)

- /** Section not machined for pressure compensator or load-hold check valve.
- K** Standard pressure compensator.
- KL** Compensator that gives 85% of specified spool's nominal flow.
- KH** Compensator that gives 120% of specified spool's nominal flow.
- KX** Compensator that gives 150% of specified spool's nominal flow.
- KAS** Compensator for systems with flow distribution. In sections with KAS compensators, the flow take-off is reduced by the same percentage at maximum flow-take-off from the pump. With a pressure difference of 20 bar between PX and LS, the flow to the motor ports is about the same as with a compensator of type KX.

If the same valve contains sections with compensators of type K, KL, KH or KX, these will be given priority over sections with KAS compensators in terms of flow take-off. This makes it easy to establish priority for a specific function.
- KAP** Compensator for systems with flow distribution. In principle, the KAP compensator works in the same way as the KAS. The difference is that there is an extra spring causing the pump to motor port connection to be closed sooner than the KAS compensator, and sections with KAS compensators are given priority over sections with KAP compensators.
- N** Section equipped with load-hold check valve.
- X** Section machined for pressure compensator or load-hold check valve, and plugged.

q (l/min) Flow rate curves

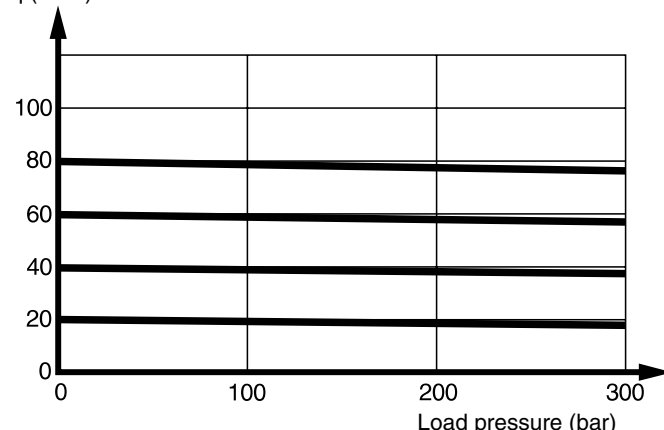

Load-independent flow with pressure compensator.

Damping of pressure compensator [67]

The LS restrictor affects the response of the pressure compensator, and is normally chosen at 0.8 mm.

- /** No LS restrictor for compensator.
- 0.45** Alternative LS restrictor for compensator.
- 0.6** Alternative LS restrictor for compensator.
- 0.8** Recommended LS restrictor for compensator.
- 1.0** Alternative LS restrictor for compensator.

Spool designations [69]

To facilitate optimal customization to meet the criteria of each individual machine function, the choice of spools is made with the aid of our computerized specification program. The information entered at items 60-66 forms part of the basis for the choice of spool.

Flow settings [72]

The strokes of spools controlled by enclosed spool-actuators can be arrested to limit the maximum flow to service ports A and B.

/ No flow settings

Qset The valve is supplied with factory-set maximum flows to the spool section. The settings agree with the specified flow-requirements to the A and B ports [61 A, B].

QsetA The valve is supplied with factory-set maximum flow to the spool section. The setting agrees with the specified flow-requirement to the A port [61 A].

QsetB The valve is supplied with factory-set maximum flow to the spool section. The setting agrees with the specified flow-requirement to the B port [61 B].

When setting the flow rates for spool sections not equipped with pressure compensators in systems fed by variable pumps, the settings are made with a pressure difference of 15 bar between the pump pressure at the PX port and the load signal at the PL port at full flow take-off.

Feed-reducing valve [75]

The L90LS with sections designated *A*, *B*, *C* or *T* at item [47] is equipped with feed-reducing valves.

Sections designated *A* have feed reduction in the A-port; Sections designated *B* have feed reduction in the B-port; those designated *C* have common feed reduction for the A-and B-ports; those designated *T* have individually adjustable feed reduction for the A-port and B-port.

Feed reduction is used for system functions that require a lower maximum pressure compared with the normal working pressure of the system. The feed-reducing valve, which is steplessly adjustable from 25 to 330 bar, reduces the delivery pressure in the service port to the pre-set level.

Through the use of feed-reducing valves, the delivery pressure can be limited without consuming any more than a pilot flow (<2 l/min).

For feed reduction to be installed, the section must be equipped with a pressure compensator. Since the feed-reducing valve is a 2-way valve, pressure shocks that arise after the feed-reducing valve must be limited with the aid of a port relief valve. The pressure setting on the port relief valve should be as close as possible to the setting on the feed-reducing valve, although at least 10 bar higher.

Setting of feed reduction in the A-port [75A]

Setting values for the A-port are from 25 to 330 bar.

Setting of feed reduction in the B-port [75B]

Setting values for the B-port are from 25 to 330 bar.

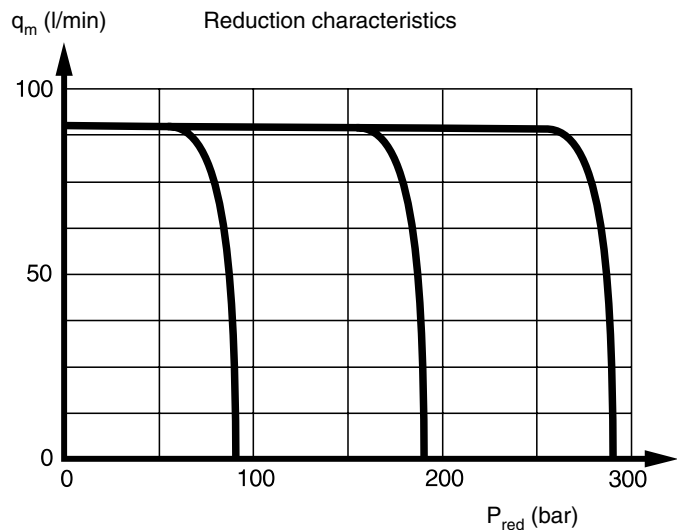

P_{red} = reduced pressure
 q_m = flow rate in service port

Port relief and/or anti-cavitation valves [76 A, B]

In spool sections designated **T [47], the cartridge can be used as a combined port-relief and anti-cavitation valve in the service ports to protect the valve and consumer from high system pressure and pressure surges.

The cartridge is a direct-acting pressure relief valve with a very fast opening sequence and good pressure characteristic. The interchangeable cartridge is factory set. The make-up function enables oil to flow from the tank gallery to the service-port side in the event of negative pressure in the service ports, in order to prevent cavitation.

- /** Section not machined for port relief valves.
- X2** Section machined for port relief valve. Service port open to tank.
- Y2** Section machined for port relief valve. Connection service ports to tank blocked with plug.
- N2** Service ports of section equipped with anti-cavitation valve.
- 50-350** Standard pressure settings (in bar) for port relief valves in A- or B-ports:
50, 63, 80, 100, 125, 140, 160, 175, 190, 210, 230, 240, 250, 260, 270, 280, 300, 320 and 350.

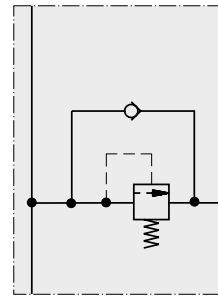

Circuit diagram for pressure relief valve.

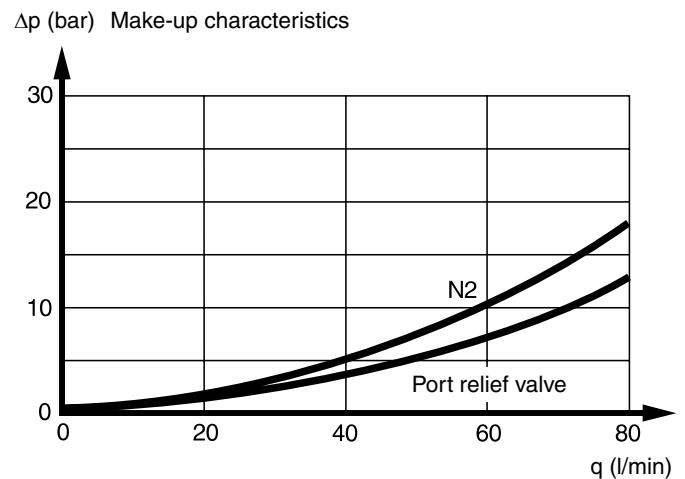
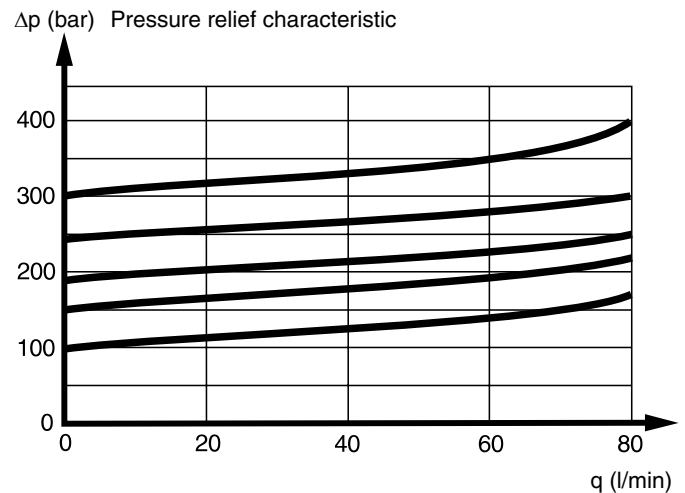

System functions

The L90LS can be equipped with integrated functions to create complete system solutions. The load signal from any service port or spool section can be connected with signal ducts and utilized to stop or limit the pressure to individual machine functions.

In cranes, this auxiliary controlling concept is implemented with the aid of the M11 function manifold [90]. Another example of how the load-signal ducts can be exploited is in the control of thrust pressure to rock drills, according to the instantaneous rotational torque (rotation-pressure controlled thrust).

System signal lines [80]

SF Valve section equipped with 3 signal lines that can be connected internally to individual load signals [81] from service port. Signal line for activation of two-speed function [82].

/ No signal lines.

Individual LS connection [81]

/ No LS connection to signal lines. No possibility of external connection either.

- A1B** Load signal from port A connected to duct 1.
- A1B1** Load signal from both port A and B connected to duct 1.
- A1B2** Load signal from port A connected to duct 1.
Load signal from port B connected to duct 2.
- A1B3** Load signal from port A connected to duct 1.
Load signal from port B connected to duct 3.
- A2B** Load signal from port A connected to duct 2.
- A2B2** Load signal from both port A and B connected to duct 2.
- A2B3** Load signal from port A connected to duct 2.
Load signal from port B connected to duct 3.
- A3B3** Load signal from both port A and B connected to duct 3.
- AB** No connection between load signal and signal ducts.
- AB2** Load signal from port B connected to duct 2.
- AB3** Load signal from port B connected to duct 3.

The load signal from more than one section can be connected to the same duct. A check valve in each section prevents backward transmission of the load signal from the ducts into individual sections.

In addition to connection with the signal ducts, the load signal is also available for external connection at the base of the valve.

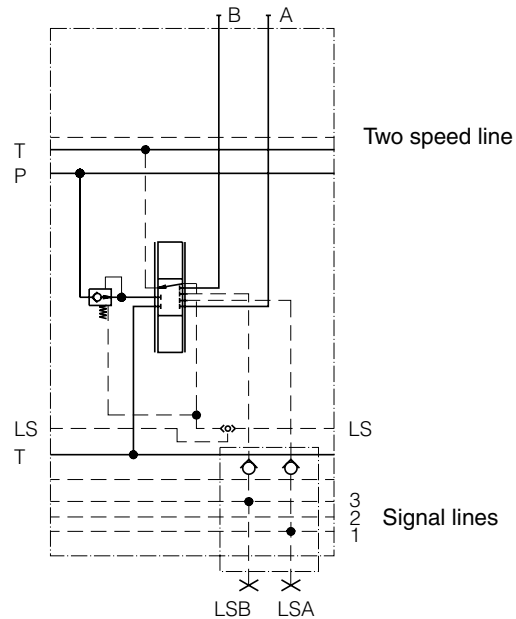

SF – System signal line

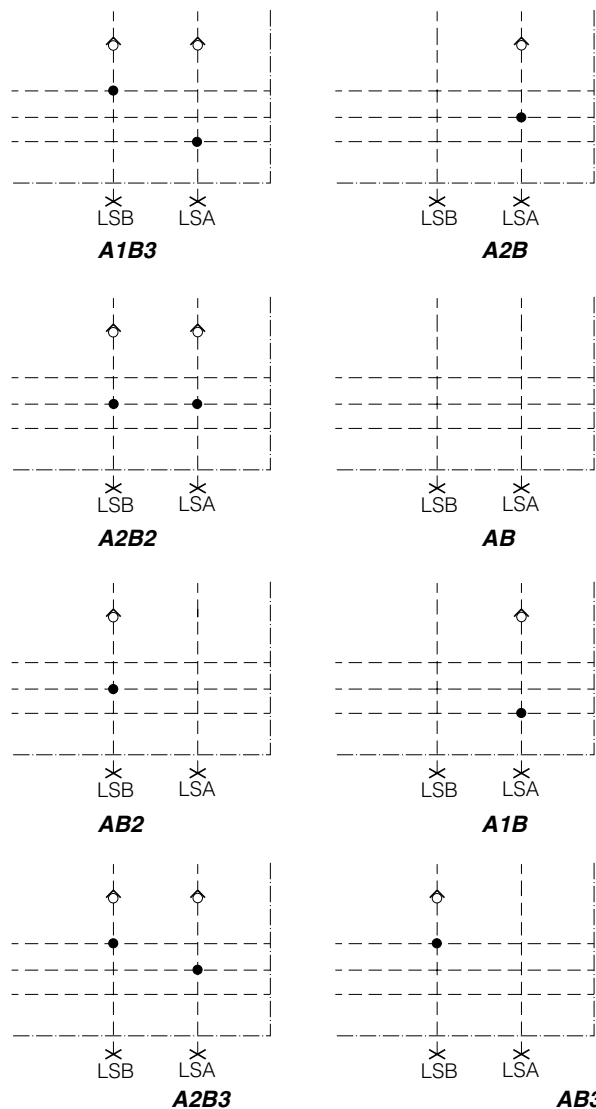

Two-speed function [82]

Any number of spool sections in the L90LS can be furnished with a two-speed function to enable switching between performance and precision work with machines such as cranes and skylifts.

The two-speed function is activated with the aid of the M10 or M11 function manifold [90]. Activation reduces the flow to the consumer as indicated below:

- QR2** Flow to consumer reduced to 20% of normal flow.
- QR3** Flow to consumer reduced to 30% of normal flow.
- QR4** Flow to consumer reduced to 40% of normal flow.
- QR5** Flow to consumer reduced to 50% of normal flow.
- /** No flow reducing.

N.B.

When a spool section is equipped with a two-speed function, the pressure compensator in the section does not have a load-hold check valve function. For this reason, overcentre valves might required for the controlled actuator.

Internal connection of service port [85]

Thanks to the internal service-port connections, system solutions employing function manifolds that require the service port to be used by the manifold can be integrated without the need for external piping.

- M** Gives internal service-port connection downstream of the spool section.
- A013** Gives internal service-port connection both downstream and upstream of the spool section.
- /** No internal service-port connection

Connectors

Connectors are not included with spool actuators, and should be ordered separately as per the lists below or ordered from your local connector supplier.

Spool actuators EC, ECH, ECHL, ECS [50]

Suitable connectors for option **A** in pos [56] are:

- AMP Junior-Timer type C, 963040-3,
- Bosch 1 928 402 404.

The connector also fit pump-unloading function BEN [22] and function manifold M10, M11, M12, M13, M13B, M17 [90].

Suitable connectors for option **D** in pos [04] are:
 Deutsch type DT06-2S.

For available connector kits from MCDE, see catalogue HY17-8558/UK.

Spool actuator ECH, ECHL, ECS [50]

Suitable connectors for option **D** in pos [56] are:

- Deutsch type DT06-2P

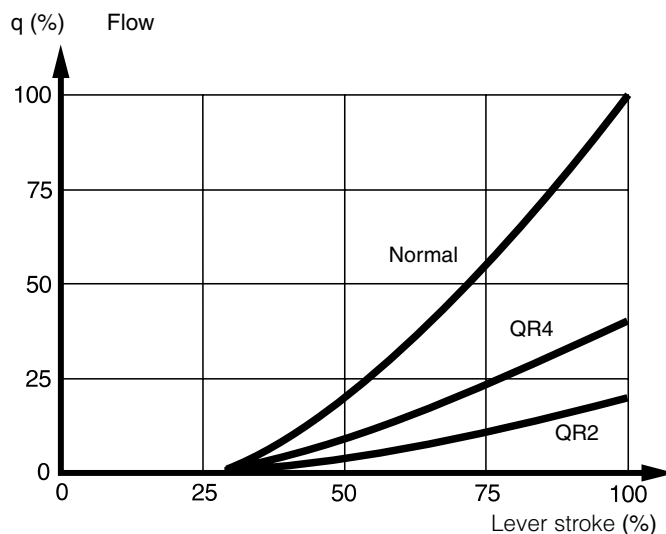
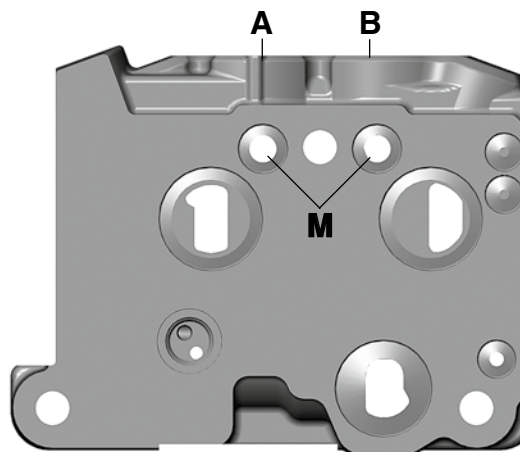

Diagram shows curves for:
 Normal flow.
 Flow with QR4 activated.
 Flow with QR2 activated.



Sectional manifold with internal connection of service ports to downstream function manifold.

Spool actuator ACE, ACEF [50]

Suitable connector type B EN 175301-803 (DIN 43650)/ISO 6952.

Complete connector sets can be ordered on following kit numbers:

Quantity	Kit No
1 off	9125 9551 00
10 off	9125 9551 10
25 off	9125 9551 25
50 off	9125 9551 50
100 off	9125 9551 99

Function manifold M14, M16 [90].

Suitable connector type A EN 175301-803 (DIN 43650)/ISO 4400.

Complete connector sets can be ordered on following kit number:

Quantity	Kit No
1 st	9121 5829 09

Function manifolds [90-99]

The L90LS can be equipped with function manifolds that enable complete system solutions to be integrated into the valve.

Standard function manifolds are available for overload protection, two-speed function, float position, priority for steering and brakes, etc. In addition to the standard units, we custom-build function manifolds to meet special system criteria. Please contact Parker for further information.

- M10 Function manifold with load signal drainage and two speed function.** The two-speed function is activated via an electric on-off valve. The pump pressure actuates the compensators, reducing the flow to the motor port. This produces a speed reduction in spool sections fitted with QR2, QR3, QR4 or QR5 [82]. Load signal draining can be used to limit the moment of load. Actuation can be prevented by draining the load signal to the tank from one or more spool sections via electric on-off valves. In this way, for example, the functions that increase the moment of load can be stopped when the machine is operated to overload. This requires system signal lines SF [80] to be machined in all spool sections and there must be an individual LS connection [81] in the spool sections using load signal drainage. To stop tensile loads, however, there must be an over-centre valve between the valve and the cylinder.
- M11 Function manifold with load signal drainage and two-speed function and the possibility of higher system pressure on speed reduction.** The manifold has the same functionality as M10, with an additional pressure relief valve affecting the pressure level from the load signal to the pump. This makes it possible to increase the system pressure when the speed is reduced.
- M12 Function manifold with float position function for preceding spool section.** The motor ports in the section can be connected to the tank via an electric on-off valve, independently of the spool position. This can be done individually for motor port A or B or for both motor ports. The on-off valves can be selected as normally closed or normally open, and if a motor port will never be connected to the tank via the manifold, a cavity plug is selected. The preceding spool section must have a side port connection M [85].
- M13 Function manifold for regenerative function with over-centre valves.** This manifold replaces the end section and is connected to the motor ports of the preceding section via side port connection M [85]. In its basic version, the M13 manifold includes a switching function for regenerative operation, passing return oil from the cylinder either to the tank via the spool in the adjacent section or regeneratively back to the cylinder (to the piston side). In this case, the flow is added to the pump flow, producing regenerative operation with a large flow to the cylinder. The piston side of the cylinder must be connected to motor port A. The regenerative function is switched on and off with a solenoid valve which uses the pressure in motor port B to set the switching spool to regenerative mode. There are two over-centre valves in the manifold, one for each motor port. The preset opening pressure is approx. 260 bar and the pilot ratio is 3:1.
The spool in the spool section must contain a leak channel, preferably type Dm1, otherwise there is a risk that insufficient pressure will be built up to operate the regenerative spool. If there is insufficient pressure, the function will start in normal mode and will switch to regenerative mode, involving a powerful thrust. If a different spool type is used, with a greater pressure drop throughout the spool stroke, there is a risk that the pres-

sure levels will be so high that it will be difficult to start the function.

As well as the basic version, the manifold is available with two-speed function QR [92], internal pilot pressure supply PSI25 [92] for electrohydraulic spool controllers or external pilot pressure supply PS25 [92] for taking pilot pressure for external consumers. The ordinary motor ports in the spool section are plugged and the cylinder is instead connected to the corresponding ports of size G 3/4 in the M13 manifold.

- M13B Function manifold for regenerative function with over-centre valves, but with higher flow capacity than M13.** This manifold has the same functions as M13, but has been developed further with larger over-centre valves for higher flows. The over-centre valves have a preset opening pressure of 280 bar. The pressure drop from port B to port A at 250 [l/min] is approx. 53 bar for M13B, compared to approx. 125 bar for M13.
- M14 Function manifold for controlling pressure in preceding spool section.** This manifold can control the pressure in the motor ports in adjacent spool sections to a variable level lower than any feed reducing valve [75]. This is done using an electrically controlled pressure relief valve in the load signal channel. Depending on the configuration, the pressure can be controlled separately for each motor port or jointly to pressure levels between 20 and 285 bar. You can choose whether the pressure control is connected all the time or is switchable using an electrically controlled on-off valve. The manifold must be placed after a spool section with side port connection, M [85]. The sections must also contain individual LS connections [81]. The system signal channel, SF [80] no. 2, connects the manifold with the spool section.
- M15 Function manifold for pump channel division between inlet and end section.** This manifold separates the pump and load signal channel from the inlet and end section. Preceding sections are supplied with pump oil and pressure relief is via the inlet section. In the following sections, pressure relief is via a preset pressure relief valve in the M15 manifold, and pump oil is supplied from the end section. Load signals for the pump are taken from the inlet section to the preceding spool sections and from the M15 manifold to the following spool sections.
- M16 Function manifold controlling the pressure in the preceding and following spool sections.** This manifold can control the pressure in the motor ports in adjacent spool sections to a variable level lower than any feed reducing valve [75]. The pressure in the preceding spool sections can be controlled in motor port A, and the pressure in the following spool sections can be controlled in motor port B. This is done using variable electrically controlled pressure relief valves in the load signal channels. The pressure level can be set between 20 and 285 bar. The manifold is placed between two spool sections containing side port connections M and A013 [85]. The sections must also contain individual LS connections [81]. The system signal channel, SF [80] no. 1, connects the manifold with the preceding sections and system signal channel no. 3 connects the following sections.
- M17 Function manifold for draining the motor ports in sections placed side by side.** The preceding spool sections must contain side port connections M [85] and the following spool sections may contain side port connections A013 [85] if draining is required there. Draining to the tank uses an electrically controlled valve. When the valve is closed, there is no leakage between the motor ports of non-return valves integrated in the manifold. Maximum drainage flow per motor port is 10 [l/min].

Levers for open spool-actuators

Levers M7 and M71 are made of steel with an anti-rust surface treatment, and fitted with a knob of black plastic. The knob on the M71 lever has a top window for the insertion of a symbol. The lever kits are delivered complete with pin sets for mounting to the valve.

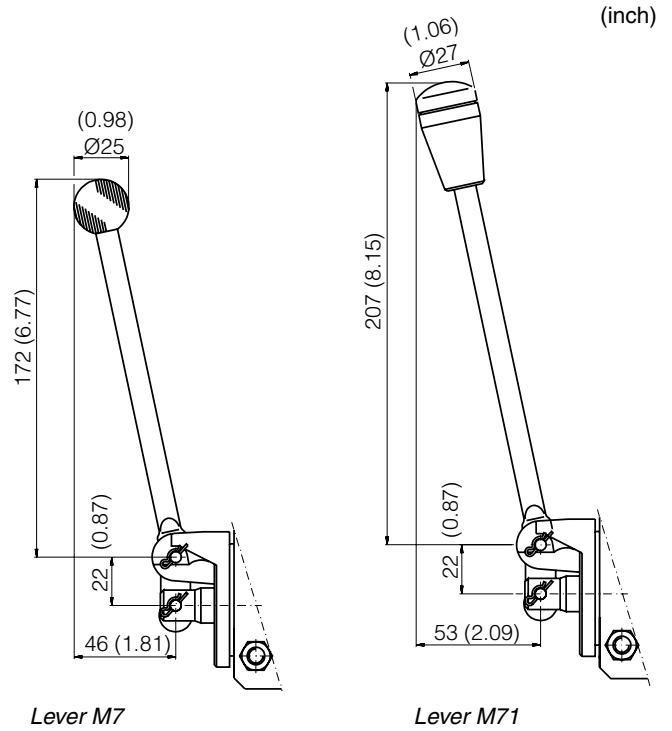

Direct lever for enclosed spool-actuators

Lever for directly operated spool-actuators with enclosed spool-end, and for remote controlled spool-actuators that have a facility for a supplementary local lever for direct control.

The ML1 lever is made of steel and has an anti-rust surface treatment. The lever knob is of black plastic and has a top window for the insertion of a symbol. The lever kit consists of a knob, the lever shaft and a lock nut.

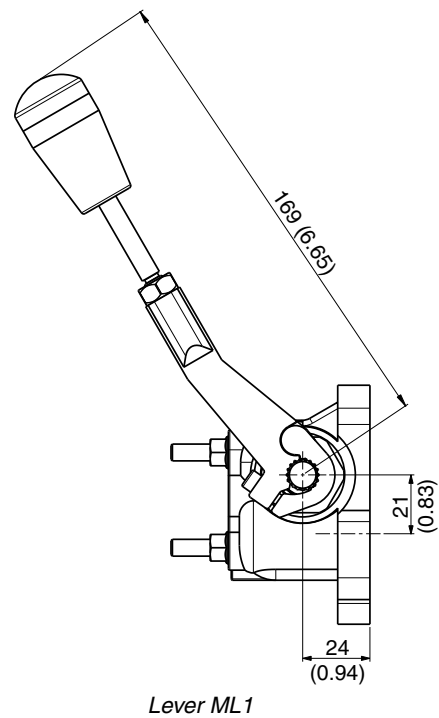

Levers are not supplied with the valve and must therefore be ordered separately.

Ordering number	Designation
9122 1780-08	M7
9122 1780-11	M71
8234 9390-01	ML1

No. of sections	L mm	L inch
1	169	(6.65)
2	209	(8.23)
3	249	(9.80)
4	289	(11.38)
5	329	(12.95)
6	369	(14.53)
7	409	(16.10)
8	449	(17.68)
9	489	(19.25)
10	529	(20.83)
11	569	(22.40)
12	609	(23.98)

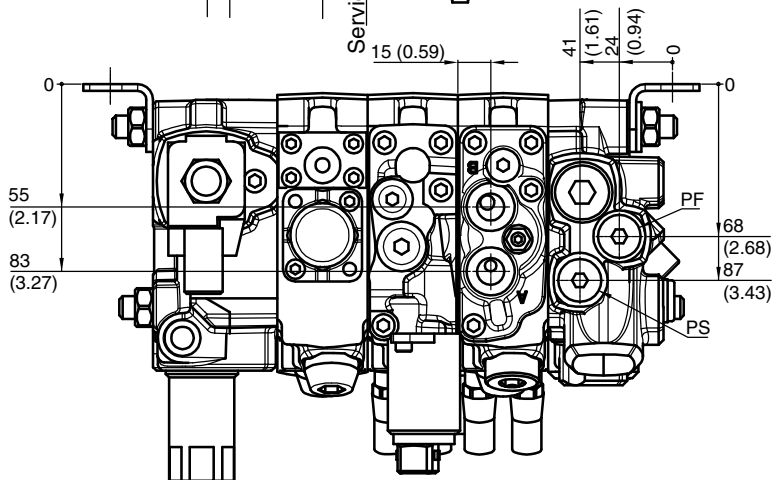
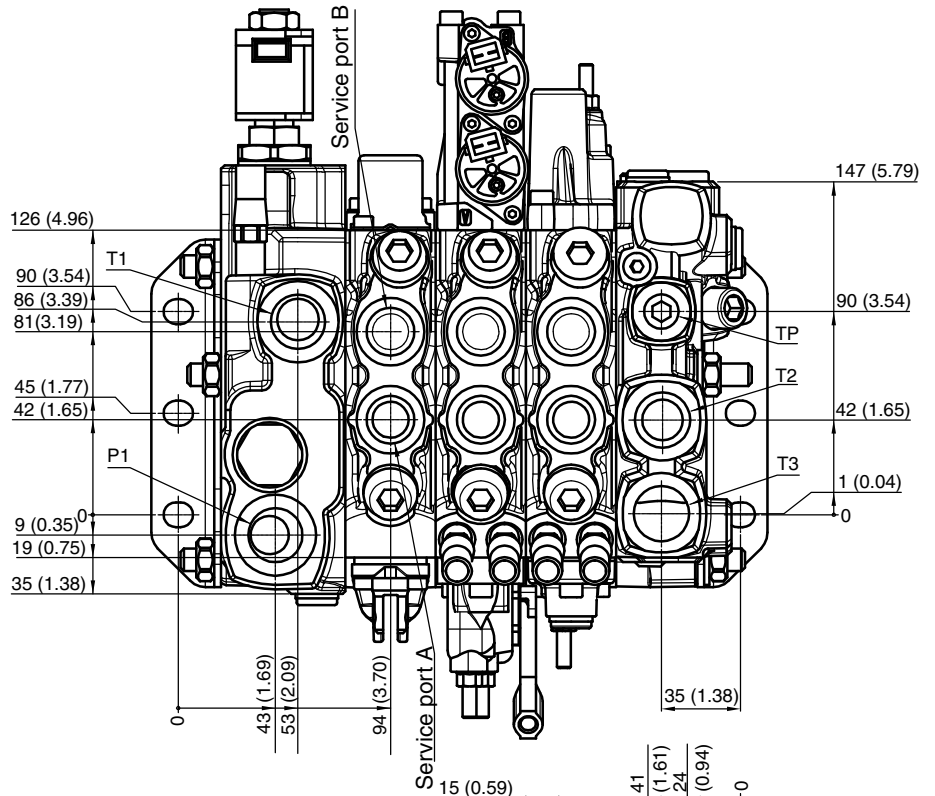
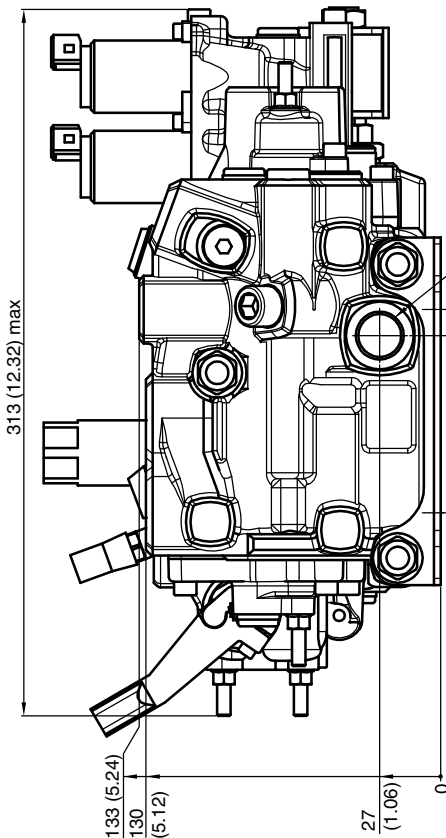
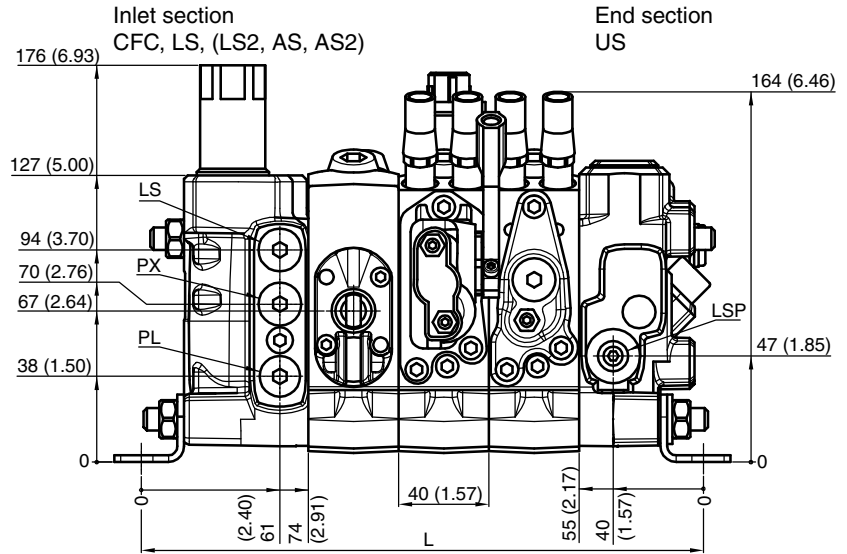

With MU section, the L dimension is reduced by 23 mm (0.91)
 With IP section, the L dimension is reduced by 25 mm (0.98)
 For connection thread, please refer to page 7.

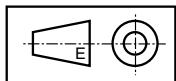

(inch)

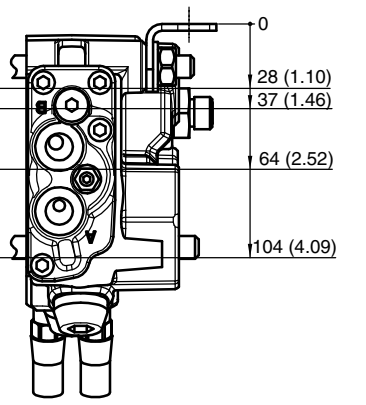
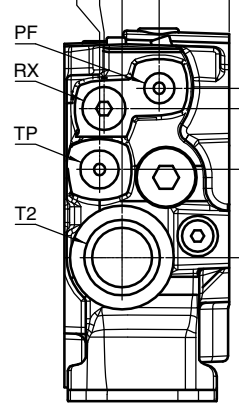
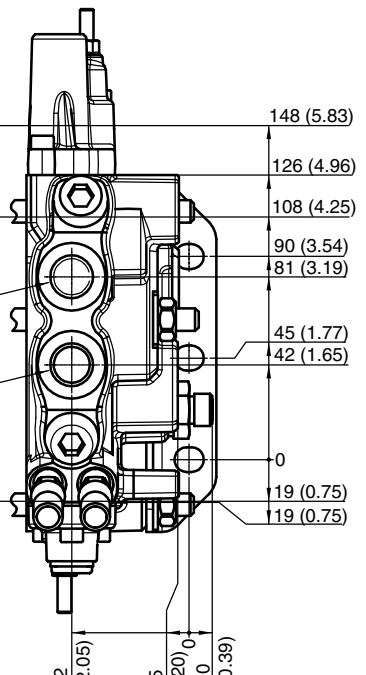
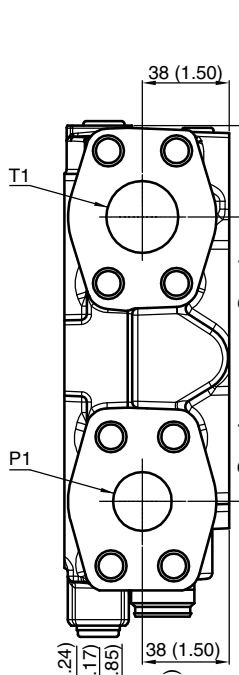
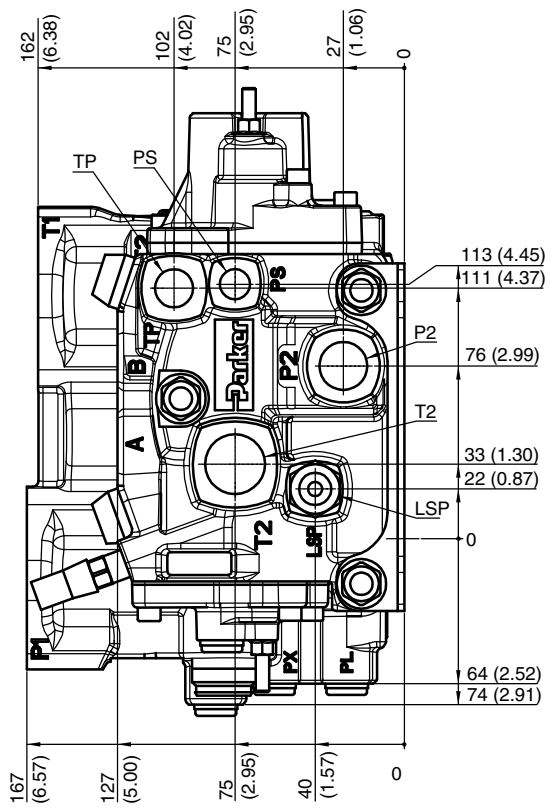
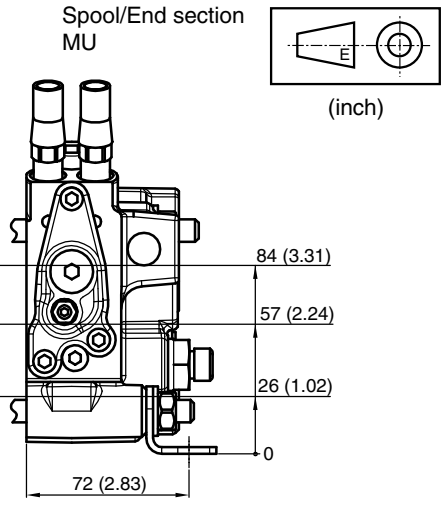
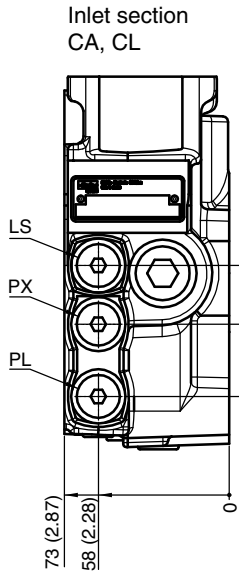
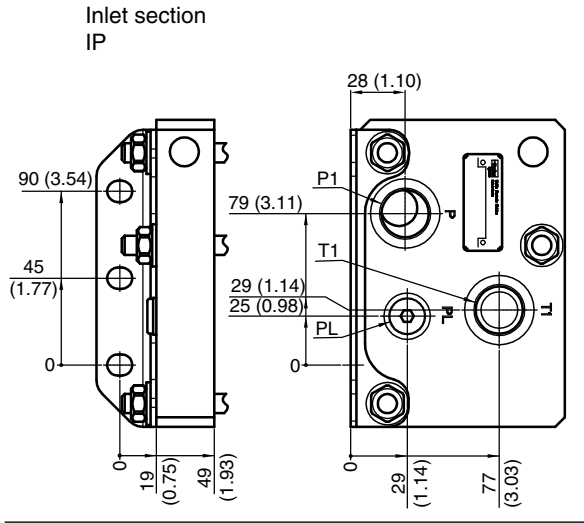

Spool actuators with open spool end

LM

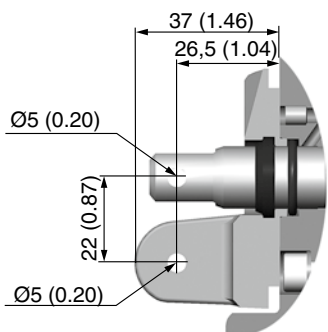

C

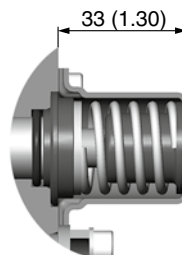

LU

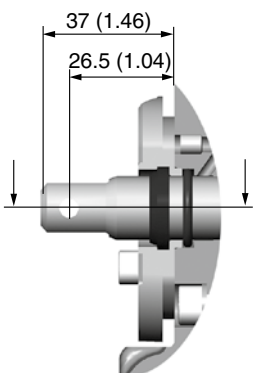

B3

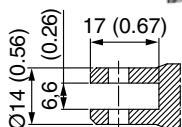
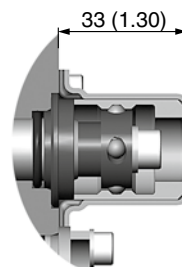

Activate P-A, B-T: 6 mm Activate P-B, A-T: 6 mm
 Maximum spool stroke

FD

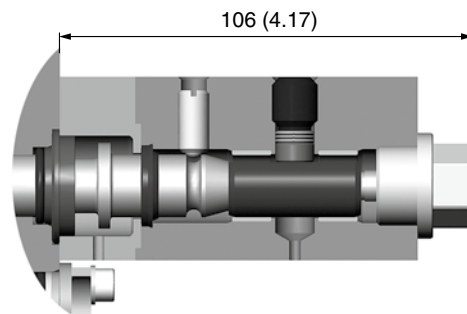

ACP

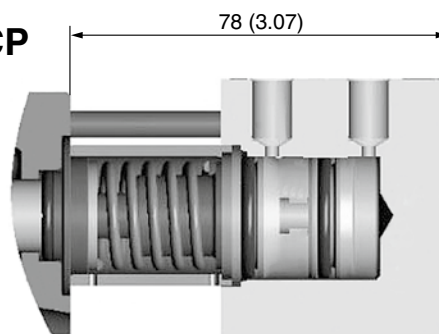

Spool actuators with open spool end

ACE/ACEF

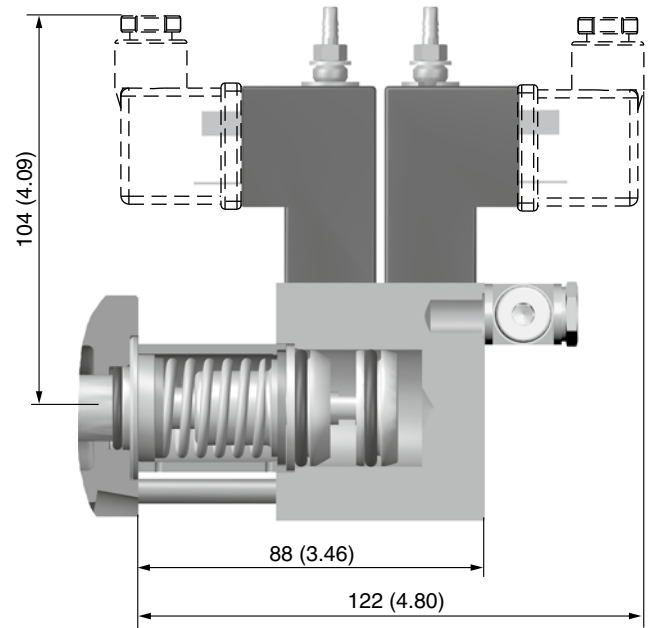

Spool actuators with closed spool end

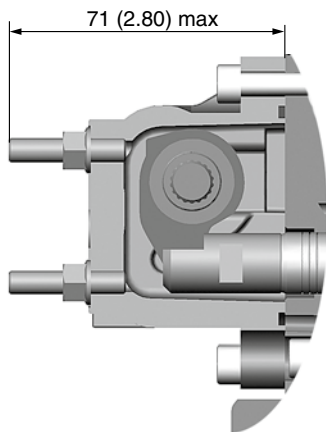

CH/CHX

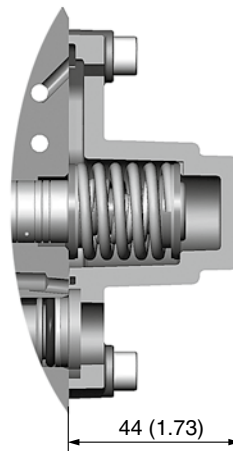

CHB3

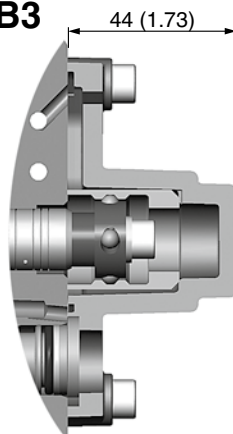

Spool actuators with closed spool end

PC/EC/ESC, A-side

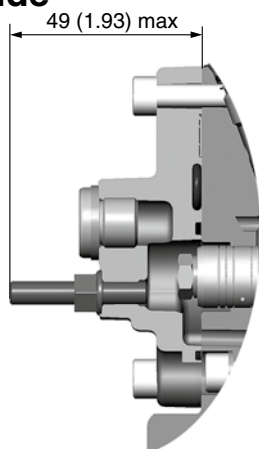

PC/PCH, B-side

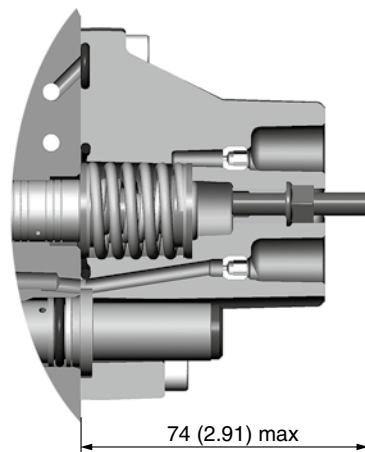

PCH/ECH/ECHL, A-side

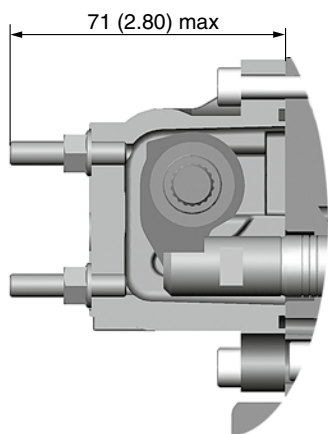

EC/ECS/ECH/ECHL, B-side

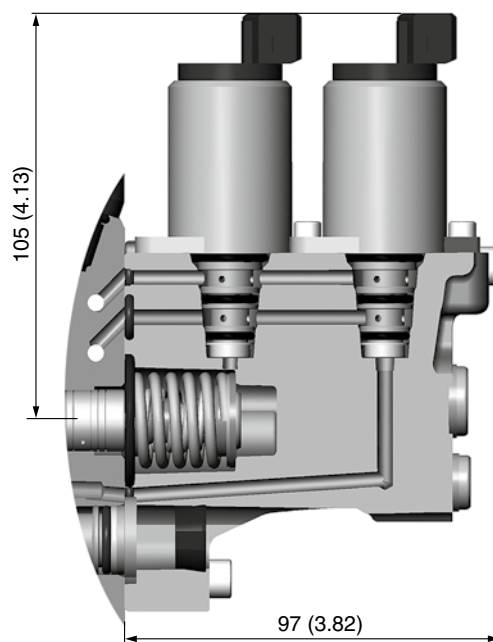

Parker Worldwide

Europe, Middle East, Africa

AE – United Arab Emirates,
Dubai

Tel: +971 4 8127100
parker.me@parker.com

AT – Austria, Wiener Neustadt
Tel: +43 (0)2622 23501-0
parker.austria@parker.com

AT – Eastern Europe, Wiener
Neustadt
Tel: +43 (0)2622 23501 900
parker.easteurope@parker.com

AZ – Azerbaijan, Baku
Tel: +994 50 2233 458
parker.azerbaijan@parker.com

BE/LU – Belgium, Nivelles
Tel: +32 (0)67 280 900
parker.belgium@parker.com

BY – Belarus, Minsk
Tel: +375 17 209 9399
parker.belarus@parker.com

CH – Switzerland, Etoy
Tel: +41 (0)21 821 87 00
parker.switzerland@parker.com

CZ – Czech Republic, Klecany
Tel: +420 284 083 111
parker.czechrepublic@parker.com

DE – Germany, Kaarst
Tel: +49 (0)2131 4016 0
parker.germany@parker.com

DK – Denmark, Ballerup
Tel: +45 43 56 04 00
parker.denmark@parker.com

ES – Spain, Madrid
Tel: +34 902 330 001
parker.spain@parker.com

FI – Finland, Vantaa
Tel: +358 (0)20 753 2500
parker.finland@parker.com

FR – France, Contamine s/Arve
Tel: +33 (0)4 50 25 80 25
parker.france@parker.com

GR – Greece, Athens
Tel: +30 210 933 6450
parker.greece@parker.com

HU – Hungary, Budapest
Tel: +36 1 220 4155
parker.hungary@parker.com

IE – Ireland, Dublin
Tel: +353 (0)1 466 6370
parker.ireland@parker.com

IT – Italy, Corsico (MI)
Tel: +39 02 45 19 21
parker.italy@parker.com

KZ – Kazakhstan, Almaty
Tel: +7 7272 505 800
parker.easteurope@parker.com

NL – The Netherlands, Oldenzaal
Tel: +31 (0)541 585 000
parker.nl@parker.com

NO – Norway, Asker
Tel: +47 66 75 34 00
parker.norway@parker.com

PL – Poland, Warsaw
Tel: +48 (0)22 573 24 00
parker.poland@parker.com

PT – Portugal, Leca da Palmeira
Tel: +351 22 999 7360
parker.portugal@parker.com

RO – Romania, Bucharest
Tel: +40 21 252 1382
parker.romania@parker.com

RU – Russia, Moscow
Tel: +7 495 645-2156
parker.russia@parker.com

SE – Sweden, Spånga
Tel: +46 (0)8 59 79 50 00
parker.sweden@parker.com

SK – Slovakia, Banská Bystrica
Tel: +421 484 162 252
parker.slovakia@parker.com

SL – Slovenia, Novo Mesto
Tel: +386 7 337 6650
parker.slovenia@parker.com

TR – Turkey, Istanbul
Tel: +90 216 4997081
parker.turkey@parker.com

UA – Ukraine, Kiev
Tel: +380 44 494 2731
parker.ukraine@parker.com

UK – United Kingdom, Warwick
Tel: +44 (0)1926 317 878
parker.uk@parker.com

ZA – South Africa, Kempton Park
Tel: +27 (0)11 961 0700
parker.southafrica@parker.com

North America

CA – Canada, Milton, Ontario
Tel: +1 905 693 3000

US – USA, Cleveland
(industrial)
Tel: +1 216 896 3000

US – USA, Elk Grove Village
(mobile)
Tel: +1 847 258 6200

Asia Pacific

AU – Australia, Castle Hill
Tel: +61 (0)2-9634 7777

CN – China, Shanghai
Tel: +86 21 2899 5000

HK – Hong Kong
Tel: +852 2428 8008

IN – India, Mumbai
Tel: +91 22 6513 7081-85

JP – Japan, Fujisawa
Tel: +81 (0)4 6635 3050

KR – South Korea, Seoul
Tel: +82 2 559 0400

MY – Malaysia, Shah Alam
Tel: +60 3 7849 0800

NZ – New Zealand, Mt Wellington
Tel: +64 9 574 1744

SG – Singapore
Tel: +65 6887 6300

TH – Thailand, Bangkok
Tel: +662 717 8140

TW – Taiwan, Taipei
Tel: +886 2 2298 8987

South America

AR – Argentina, Buenos Aires
Tel: +54 3327 44 4129

BR – Brazil, Sao Jose dos
Campos
Tel: +55 12 4009 3500

CL – Chile, Santiago
Tel: +56 2 623 1216

MX – Mexico, Apodaca
Tel: +52 81 8156 6000

VE – Venezuela, Caracas
Tel: +58 212 238 5422

EMEA Product Information Centre

Free phone: 00 800 27 27 5374

(from AT, BE, CH, CZ, DE, DK, EE, ES, FI, FR, IE, IL,
IS, IT, LU, MT, NL, NO, PL, PT, RU, SE, SK, UK, ZA)

US Product Information Centre

Toll-free number: 1-800-27 27 537

www.parker.com

