

General Description

Series NS needle valves provide excellent speed control and shutoff for hydraulic applications where a reverse-flow check valve is not required. They also take minimum space for installation, conserving space.

The two-step needle valve allows fine tuning at low flow with the first three turns of the adjusting knob, with full-open flow plus conventional precision throttling with the final three turns of the knob.

Exclusive “Colorflow” color bands permit fast, accurate setting and time-saving return to a previous setting.

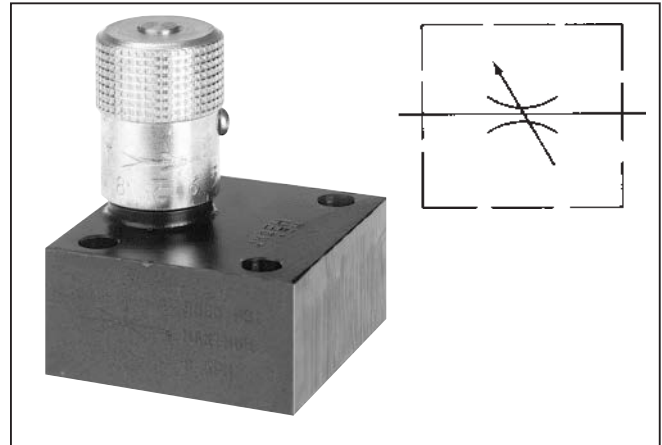

Features

- The exclusive “Colorflow” color-band reference scale on the valve stem is a great convenience and time-saver in setting the valve originally and in returning it to any previous setting.
- A simple set screw locks the valve on any desired setting.

Flow Data

Valve Model	Flow, Max. GPM (L/M)	Orifice Area Control Flow (Sq. In.)	Effective Control Flow CV	Port Size
NS400	5 (19)	.0194	.443	1/4
NS600	8 (30)	.0344	.787	3/8
NS800	15 (57)	.0427	.976	1/2
NS1200	25 (95)	.1080	2.470	3/4
NS1600	40 (151)	.2300	5.250	1

D

Specifications

Maximum Operating Pressure	210 Bar (3000 PSI)
Needles	Standard Needle on all models Fine needle optional on Models NS400 and NS600
Nominal Flow	D600 37.9 LPM (10 GPM) D1200 132.5 LPM (35 GPM)
Port Configurations	See dimensional drawings and/or ordering information for configuration availability

Performance Curves

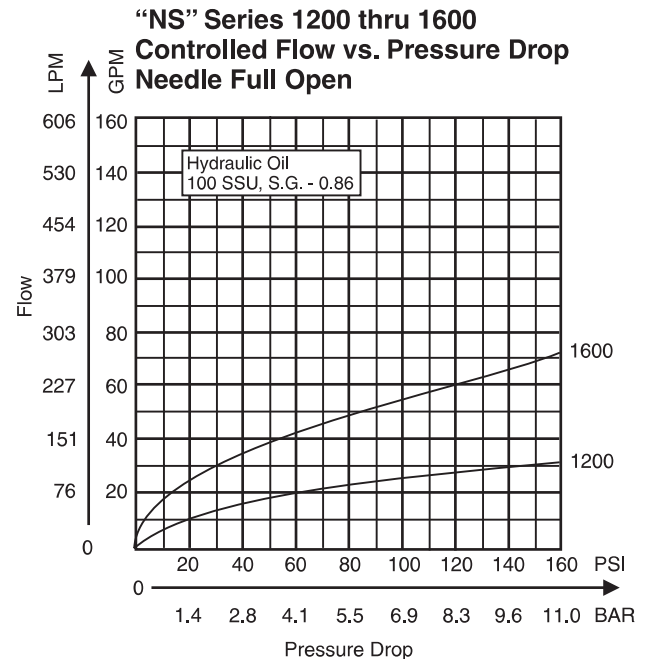
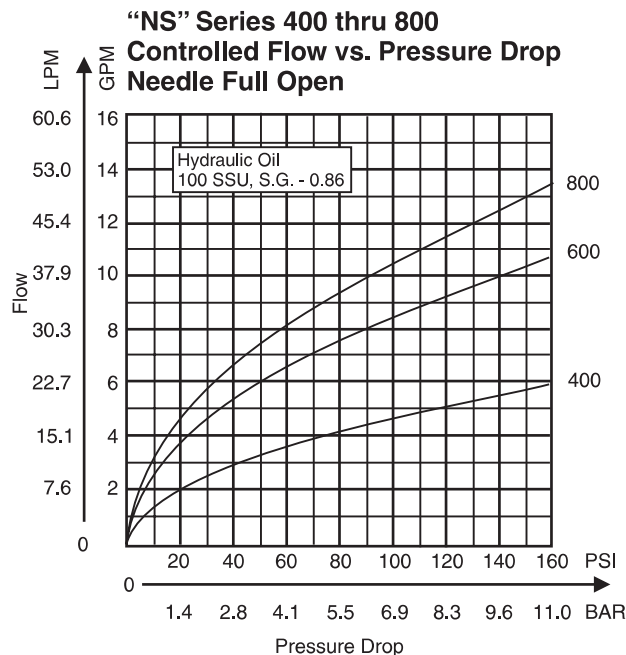

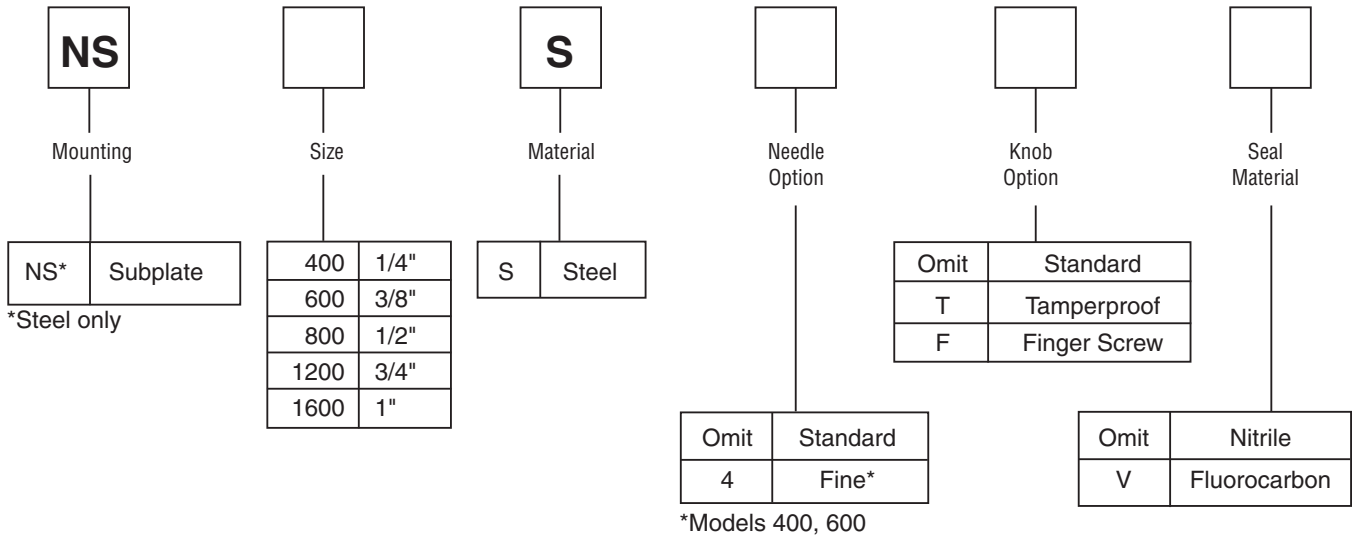

Bolt Kits

Valve	Bolt Kit	Bolt Specification*	Bolt Torque
NS400	BK01	1/4-20 x 1-1/4"	9 Ft.-Lbs.
NS600	BK02	1/4-20 x 1-1/2"	9 Ft.-Lbs.
NS800	BK02	1/4-20 x 1-1/2"	9 Ft.-Lbs.
NS1200	BK05	5/16-18 x 1-3/4"	19 Ft.-Lbs.
NS1600	BK08	5/16-18 x 2-1/4"	19 Ft.-Lbs.

*Use SAE Grade 8 or Better.

Knob Options

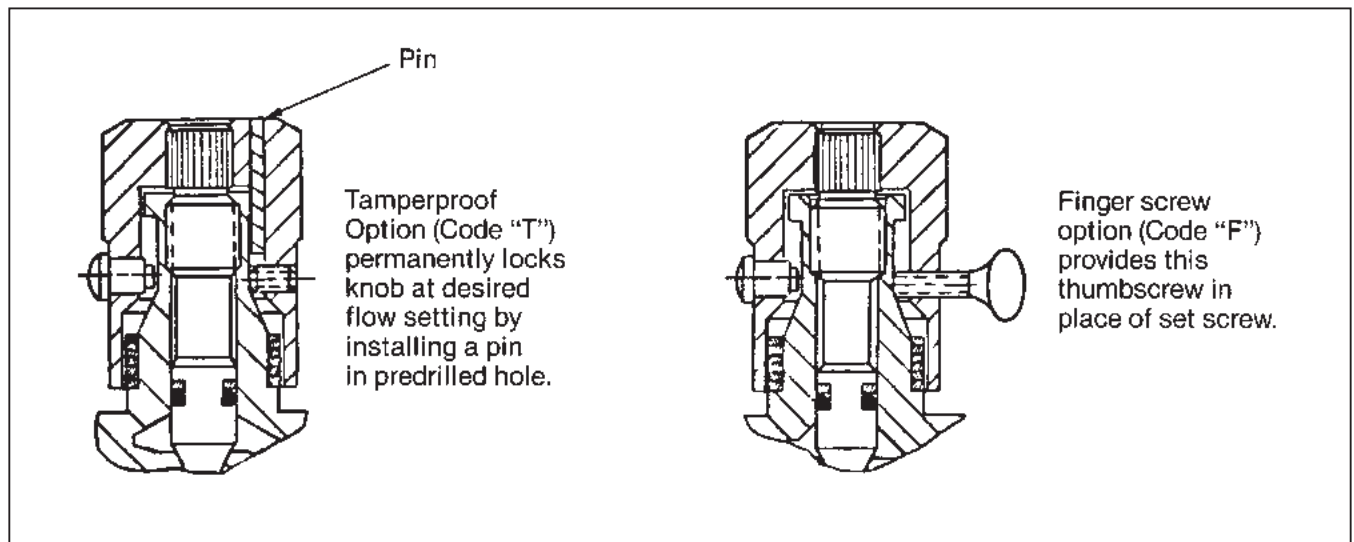

Millimeter equivalents for inch dimensions are shown in (**)

Models NS400S through NS1600S

Manifold mounted Needle Valves

D

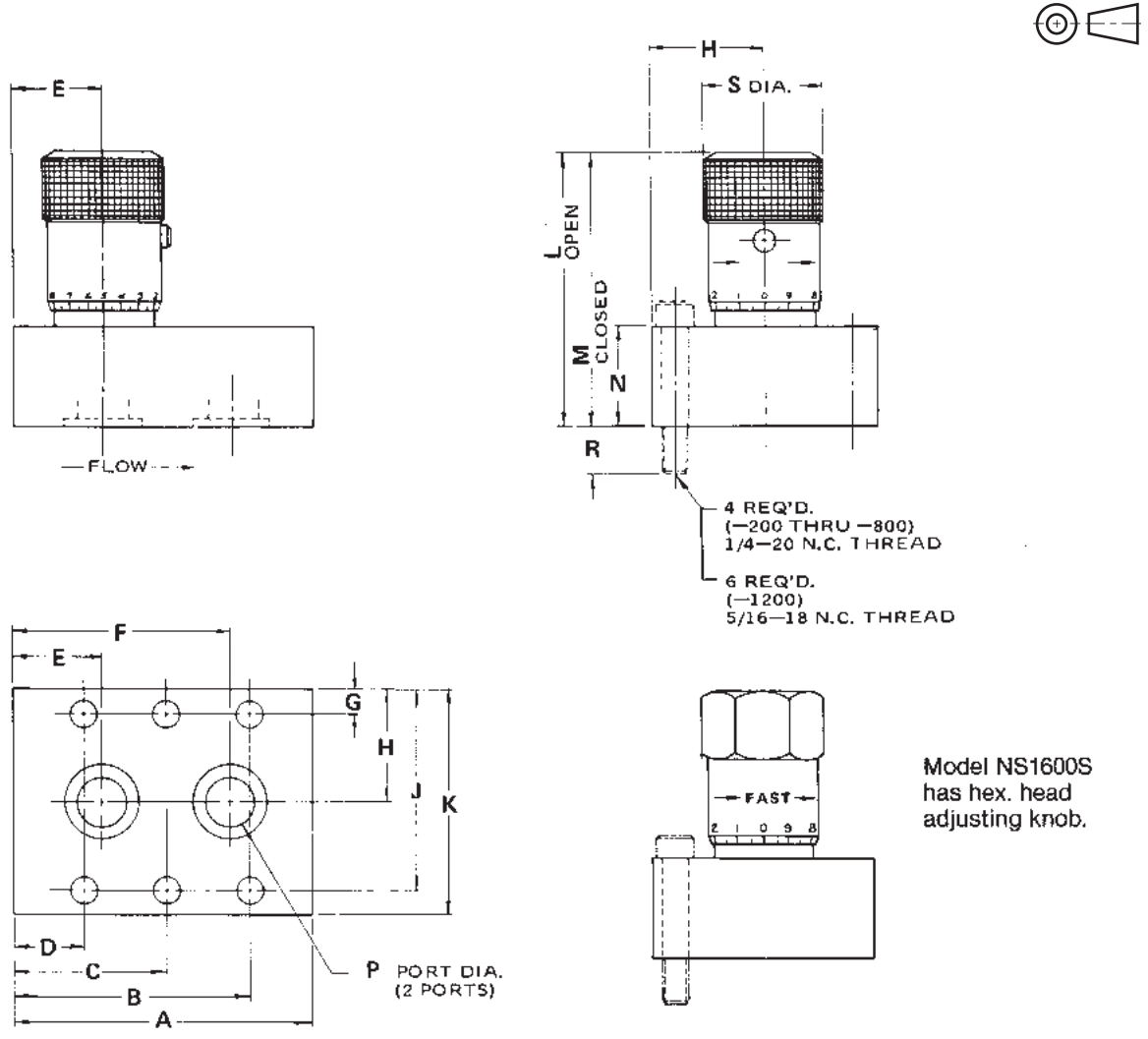

Model NS1600S has hex. head adjusting knob.

Valve Model	A	B	C	D	E	F	G	H	J	K	L	M	N	P	R	S	Weight Lb. (Kg)
NS400S	1.88 (47.8)	1.62 (41.1)		.25 (6.4)	.44 (11.2)	1.44 (36.6)	.22 (5.6)	.88 (22.4)	1.53 (38.9)	1.75 (44.5)	2.15 (54.6)	1.95 (49.5)	.88 (22.4)	.28 (7.1)	.44 (11.2)	.81 (20.6)	0.8 (0.4)
NS600S	2.00 (50.8)	1.66 (42.2)		.34 (8.6)	.50 (12.7)	1.50 (38.1)	.25 (6.4)	1.00 (25.4)	1.75 (44.5)	2.00 (50.8)	2.65 (67.3)	2.40 (61.0)	1.00 (25.4)	.34 (8.6)	.50 (12.7)	1.00 (25.4)	1.3 (0.6)
NS800S	2.97 (75.4)	2.23 (56.6)		.73 (18.5)	.89 (22.6)	2.08 (52.8)	.25 (6.4)	1.12 (28.4)	2.00 (50.8)	2.25 (57.2)	3.04 (77.2)	2.75 (69.9)	1.00 (25.4)	.47 (11.9)	.50 (12.7)	1.18 (30.0)	2.3 (1.0)
NS1200S	3.69 (93.7)	3.34 (84.8)	1.84 (46.7)	.34 (8.6)	.78 (19.8)	2.92 (74.2)	.31 (7.9)	1.38 (35.1)	2.44 (62.0)	2.75 (69.9)	3.72 (94.5)	3.13 (79.3)	1.12 (28.4)	.66 (16.8)	.63 (16.0)	1.37 (34.8)	3.7 (2.0)
NS1600S	4.38 (111.3)	4.06 (100.1)	2.19 (55.6)	.31 (7.9)	1.06 (26.9)	3.31 (84.1)	.31 (7.9)	1.50 (38.1)	2.69 (68.3)	3.00 (76.2)	5.51 (140.0)	4.85 (123.2)	1.75 (44.5)	.88 (22.4)	.50 (12.7)	1.87 (47.5)	8.0 (4.0)

Millimeter equivalents for inch dimensions are shown in (**)

Subplate

Reference Data Only

(Subplates are not available)

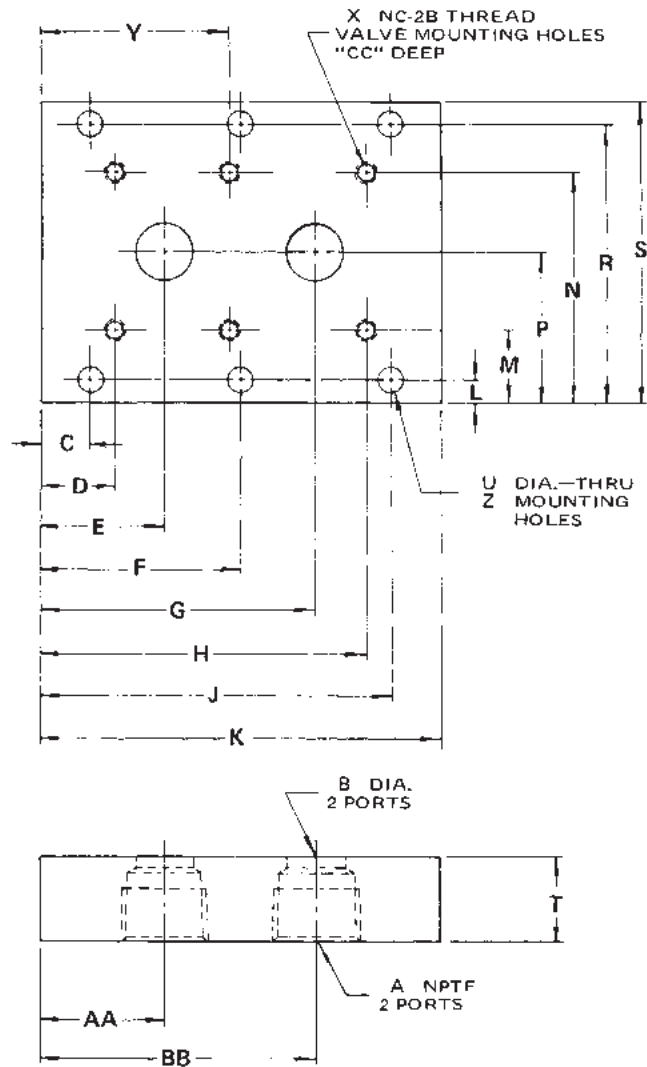

NPTF Port Size	Valve Series				
	NS -400	NS -600	NS -800	NS -1200	NS -1600
B	.281 (7.1)	.406 (10.3)	.469 (11.9)	.656 (16.7)	.875 (22.2)
C	.375 (9.5)	.375 (9.5)	.500 (12.7)	.344 (8.7)	.344 (8.7)
D	.562 (14.3)	.843 (21.4)	.875 (22.2)	.750 (19.1)	1.125 (28.6)
E	.750 (19.1)	1.000 (25.4)	1.031 (26.2)	1.188 (30.2)	1.875 (47.6)
G	1.750 (44.5)	2.000 (50.8)	2.219 (56.4)	3.312 (84.1)	4.125 (104.8)
H	1.938 (49.2)	2.156 (54.8)	2.375 (60.3)	3.750 (95.3)	4.875 (123.8)
J	2.125 (54.0)	2.625 (66.7)	2.750 (69.9)	4.156 (105.6)	5.656 (143.6)
K	2.50 (63.5)	3.00 (76.2)	3.25 (82.6)	4.50 (114.3)	6.00 (152.4)
L	.344 (8.7)	.250 (6.4)	.438 (11.1)	.344 (8.7)	.344 (8.7)
M	.844 (21.4)	.750 (19.1)	1.125 (28.6)	1.062 (27.0)	1.062 (27.0)
N	2.156 (54.8)	2.250 (57.2)	2.875 (73.0)	3.188 (81.0)	3.438 (87.3)
P	1.500 (38.1)	1.500 (38.1)	2.000 (50.8)	2.125 (54.0)	2.250 (57.2)
R	2.656 (67.5)	2.750 (69.9)	3.562 (90.5)	3.906 (99.2)	4.156 (105.6)
S	3.00 (76.2)	3.00 (76.2)	4.00 (101.6)	4.25 (108.0)	4.50 (114.3)
T	1.125 (28.6)	1.125 (28.6)	1.125 (28.6)	1.125 (28.6)	1.250 (31.8)
U	.281 (7.1)	.281 (7.1)	.359 (9.1)	.422 (10.7)	.422 (10.7)
X	1/4-20	1/4-20	1/4-20	5/16-18	5/16-18
Y	—	—	—	2.250 (57.2)	3.000 (76.2)
Z	4 Holes	4 Holes	4 Holes	6 Holes	6 Holes
AA	.750 (19.1)	1.000 (25.4)	1.031 (26.2)	1.188 (30.2)	1.875 (47.6)
BB	1.750 (44.5)	2.000 (50.8)	2.219 (56.4)	3.312 (84.5)	4.125 (104.8)
CC	.505 (12.8)	.525 (13.3)	.525 (13.3)	.525 (13.3)	.525 (13.3)

D