

Flow control,
cartridge restrictor
Common cavity, Size 16

ST-C-16

OD.21.01 - X - 75

RE 18321-29

Edition: 03.2016

Replaces: 02.2011



Technical data

Max. operating pressure	350 bar (5000 psi)
Rated flow	150 l/min. (39 gpm)
Fluid temperature range	-30 to 100 °C (-22 to 212 °F)
Installation torque	80 - 100 Nm (59 - 74 ft-lbs)
Weight	0.31 kg (0.68 lbs)
Cavity	CA-16A-2N (see data sheet 18325-70)
Lines bodies and standard assemblies	Please refer to section "Hydraulic integrated circuit" or consult factory
Seal kit ¹⁾	Code: RG16A2010530100 material no: R930003262
Fluids	Mineral-based or synthetics with lubricating properties at viscosities of 10 to 500 mm ² /s (cSt)
Recommended degree of fluid contamination	Nominal value max. 10µm (NAS 8) / ISO 4406 19/17/14
Installation	No restrictions
Other Technical Data	See data sheet 18350-50

Description

Increasing the orifice value from fully closed to fully open, flow is permitted and regulated bi-directional from 1 to 2 and from 2 to 1. With valve fully closed no leakage permitted between ports 1 and 2.

1) Only external seals for 10 valves

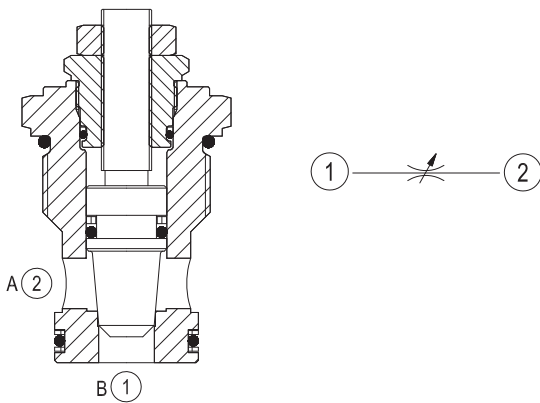

Characteristic curve

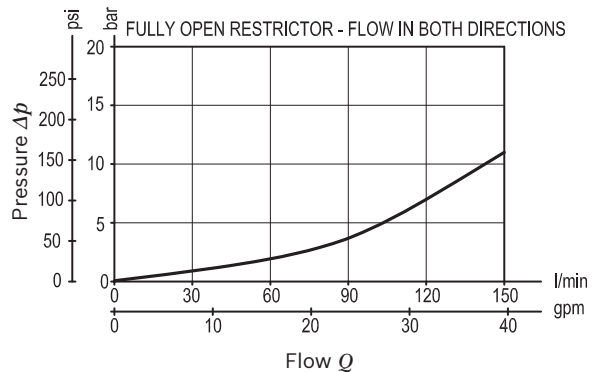

Ordering code

OD.21.01	X	75	00	*
-----------------	----------	-----------	-----------	----------

Flow control, cartridge restrictor

Series 0/A to L
unchanged performances and dimensions

Adjustments

03 Leakproof hex. socket screw

04 Handknob and locknut

Version and options standard

75 Common cavity, Size 16

Preferred types

Type	Material number
OD210103750000	R901109837
OD210104750000	R901109838

Type	Material number

Dimensions

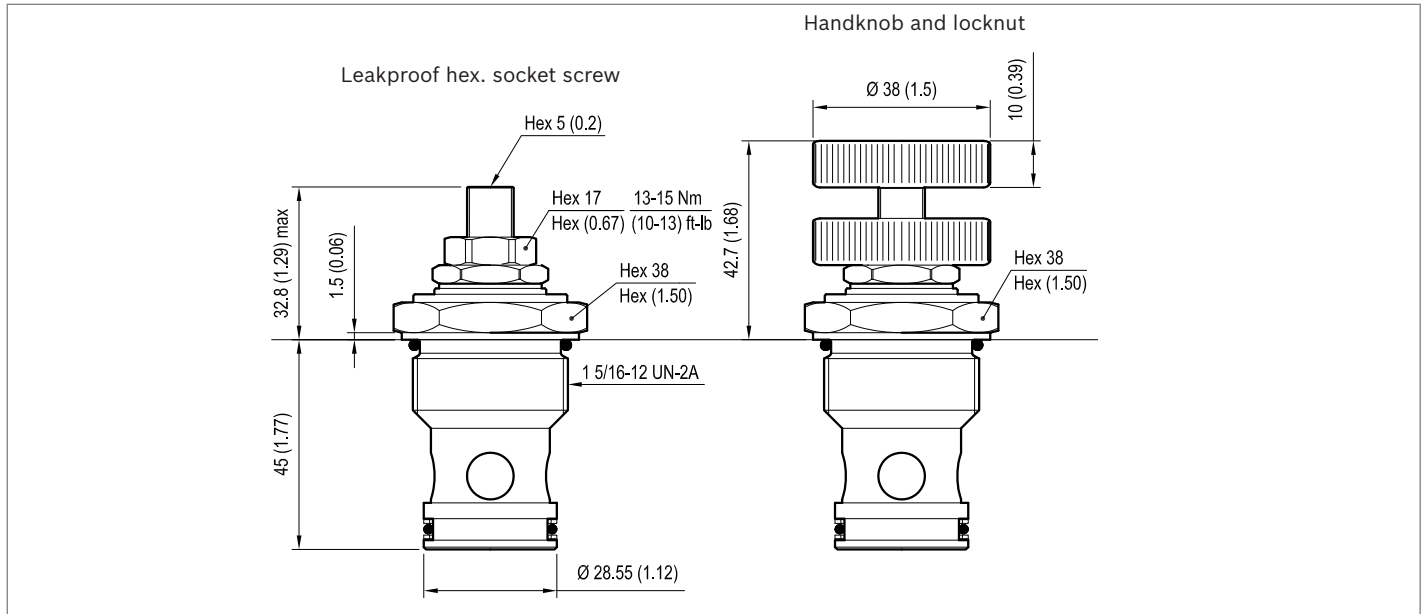

Bosch Rexroth Oil Control S.p.A.

Via Leonardo da Vinci 5
P.O. Box no. 5
41015 Nonantola – Modena, Italy
Tel. +39 059 887 611
Fax +39 059 547 848
compact-hydraulics-cv@boschrexroth.com
www.boschrexroth.com/compacthydraulics

© This document, as well as the data, specifications and other information set forth in it, are the exclusive property of Bosch Rexroth Oil Control S.p.a.. It may not be reproduced or given to third parties without its consent. The data specified above only serve to describe the product. No statements concerning a certain condition or suitability for a certain application can be derived from our information. The information given does not release the user from the obligation of own judgment and verification. It must be remembered that our products are subject to a natural process of wear and aging. Subject to change.