

**PROPORTIONAL VALVES  
DIRECT ACTING PRESSURE REDUCING  
CARTRIDGE STYLE**

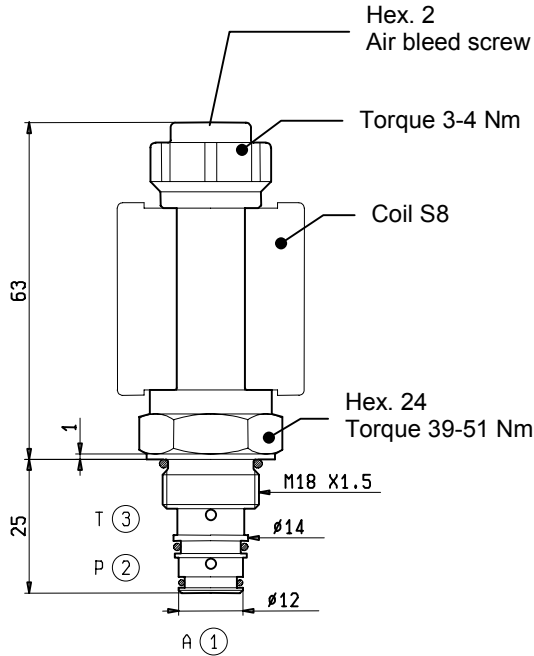

**VEP-8I-3R-03**

**OD.91.01.81.23.01**



Allowed Back Pressure at port 3(T): 5 bar max.

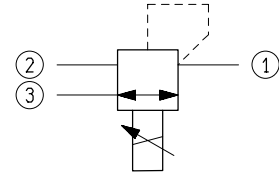

**TECHNICAL DATA**

Maximum Inlet Pressure in 2	350	bar
Reduced Pressure in 1	4-25	bar
Rated Flow	2	l/min
I Max(±10%) for coil 12 V DC	1.15	A
I Min(±10%) for coil 12 V DC	0.4	A
Recommended PWM frequency	120-150	Hz
Cavity - Tooling (081-E)	page 7.01.150	
Weight	0.135	kg
Fluids - Temperatures	page 7.01.040	
Testing Conditions - Seals	page 7.01.040	
Internal leakage at 350 bar with 46 cst oil	Max.5	cm <sup>3</sup> /min
Filtration : 10 µm nominal or better	page 7.01.050	
Coils must be ordered separately	page 1.71.050	
Mounting Position	unrestricted	
N.B. It is recommended to bleed air carefully before operation.		

