

Pilot operated check valves Poppet type, with pre-opening

OVP Series

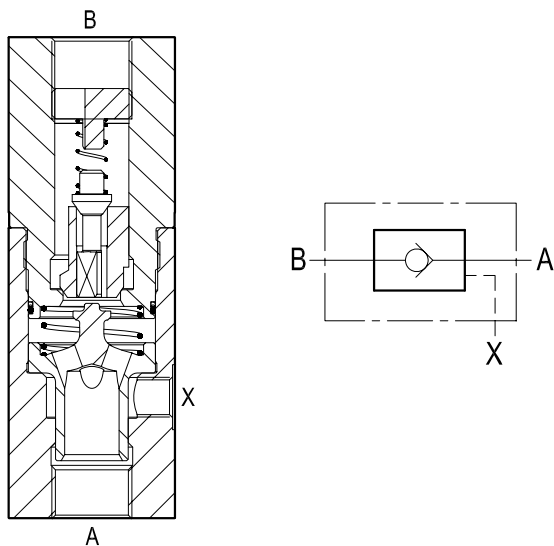

Description

Flow is always allowed to pass from A to B when pressure at A rises above the spring bias pressure and the poppet is pushed from the seat. The valve is normally closed (checked) from B to A; when sufficient pilot pressure is present at Pil port (X), the annular pilot area pushes the pre-opening poppet from its seat and oil starts flowing from B to A; as pilot pressure increases, also the main poppet is lifted from its seat and the opening area B-A becomes larger. Precision machining and hardening process allow virtually leak-free performance in the checked condition. The valve is available in different sizes and versions for different flow ranges, as specified by the tables of the Technical data, Performance diagrams and Dimensions.

Technical data

Code	Pressure P max bar (psi)	Flow Q max l/min (gpm)	Weight kg (lbs)	Pilot ratio	
				Main opening	Pre opening
OVP 19	250 (3600)	100 (26)	2.6 (5.8)	1:4.5	1:11
OVP 25	250 (3600)	150 (40)	5.0 (11)	1:4	1:13
OVP 32	250 (3600)	150 (40)	5.2 (11.5)	1:4	1:13

Steel body, zinc plated

Performance

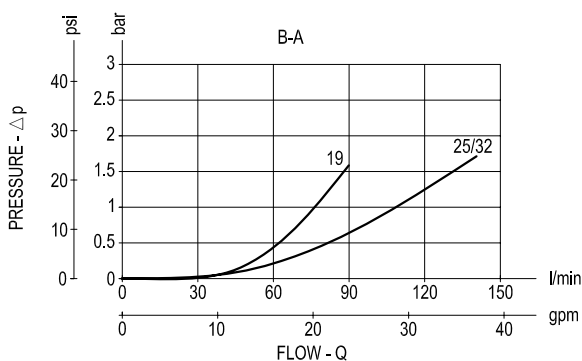
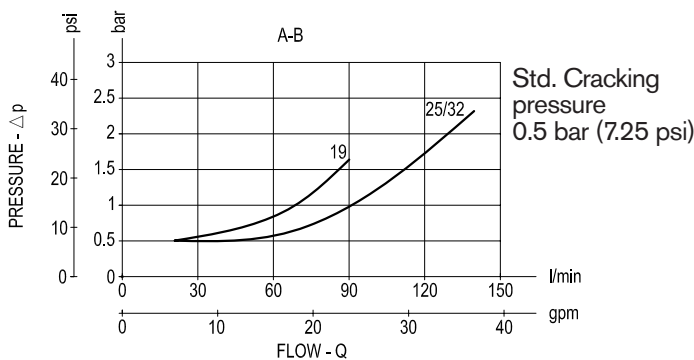

Advantages

- Very compact design and inline mounting for space saving.
- Mounting position is unrestricted.
- Three sizes provide great adaptability to the system.

Dimensions

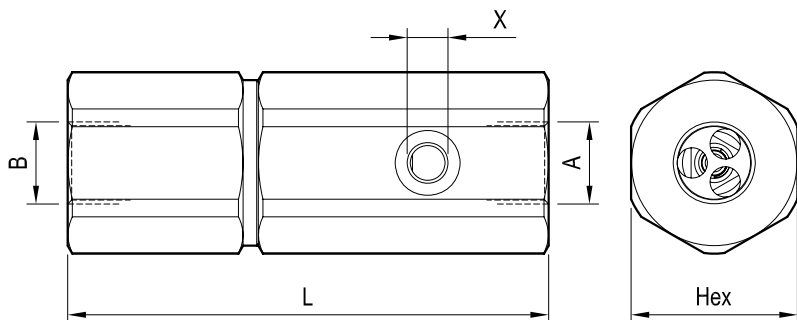

Ports size / Dimensions

Code	Ports size		Hex mm (inches)	L mm (inches)
	A-B	X		
OVP 19	G 3/4	G 1/4	55 (2.17)	159 (6.26)
OVP 25	G 1	G 1/4	70 (2.76)	186 (7.32)
OVP 32	G 1-1/4	G 1/4	70 (2.76)	193 (7.60)

Applications

Ideal to lock cylinders in a leak free mode in order lock or clamp loads. They are ON-OFF valves suitable for holding applications; the pre-opening does provide a degree of smooth opening and allows some motion control, but these valves are not designed to control overrunning loads which would cause a loss of pilot pressure. They should not be used for paired cylinders and, when fitted to the cylinder annular chamber, the main pilot ratio should be significantly higher than the cylinder ratio. In case of doubt, please consult us.

Ordering code

OVP

series 19	= 19
series 25	= 25
series 32	= 32

Cracking pressure (free flow) is always 0.5 bar (7.25psi)

Type	Material number	Type	Material number	Type	Material number
OVP19	R932500377				
OVP25	R932500378				
OVP32	R932500379				