

FUNCTION

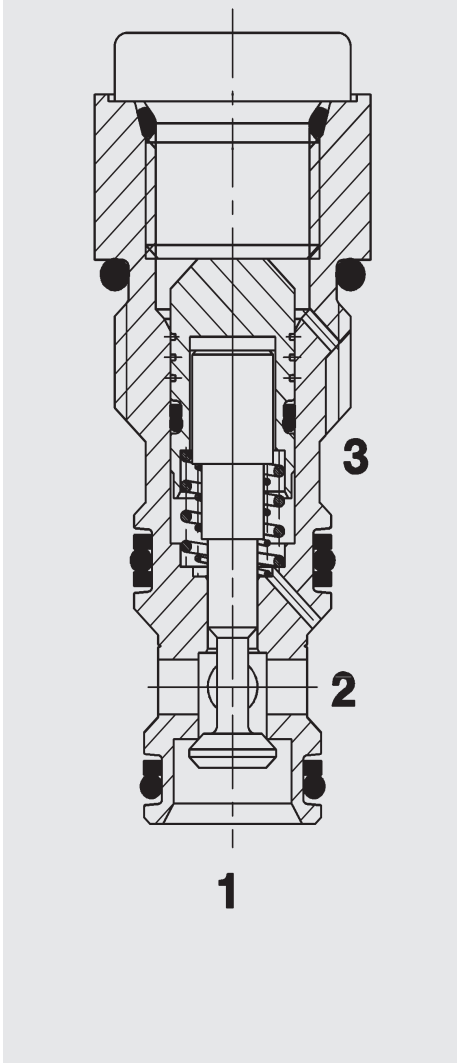

The pilot-to-open check valve is a direct-acting, spring-loaded poppet valve. The valve allows flow from port 2 to 1. In the opposite direction, the poppet is pressed onto the seat and blocks flow. If a sufficiently high control pressure is applied at port 3, the poppet is lifted from the valve seat and oil flows from 1 to 2. The necessary pilot pressure at port 3 is dependent on the pressures across port 1 and 2.

The following applies: $p_{\text{control}} = \frac{p_{\text{port 1}} - p_{\text{port 2}}}{\varphi} + p_{\text{port 2}}$

Check Valve pilot-to-open poppet type, direct-acting UNF Cartridge – 350 bar

RP08A-01

FEATURES

- Spring return in the pilot stage for safe valve operation
- Quick response
- Low leakage design
- Optional pilot piston seal
- Corrosion protection of external surfaces through blue zinc-plating or thermochemical Nitrotec coating (black)

SPECIFICATIONS*

Operating pressure:	max. 350 bar
Nominal flow:	max. 38 l/min
Leakage:	leakage-free max. 5 drops/min (0,25 cm ³ /min) at nominal pressure
Leakage 2 to 3:	< 5 l/min at 350 bar (40 °C HLP 46) For versions without O-ring on pilot piston
Cracking pressure	1.00 bar
Pilot ratio:	3:1 ; 4:1
Media operating temperature range:	-30 °C to +100 °C
Ambient temperature range:	-30 °C to +100 °C
Operating fluid:	Hydraulic oil to DIN 51524 Part 1, 2 and 3
Viscosity range:	7.4 to 420 mm ² /s
Filtration:	Class 21/19/16 according to ISO 4406 or cleaner
MTTF _d :	150 - 1200 years, according to DIN EN ISO 13849-1
Installation:	No orientation restrictions
Material:	Valve body: steel Pilot: steel Poppet: hardened and ground steel Seals: NBR (standard) FKM (optional, media temperature range -20 °C to +120 °C)
Cavity:	FC08-3
Weight:	0.088 kg

* see "Conditions and instructions for valves" in brochure 53.000

DIMENSIONS

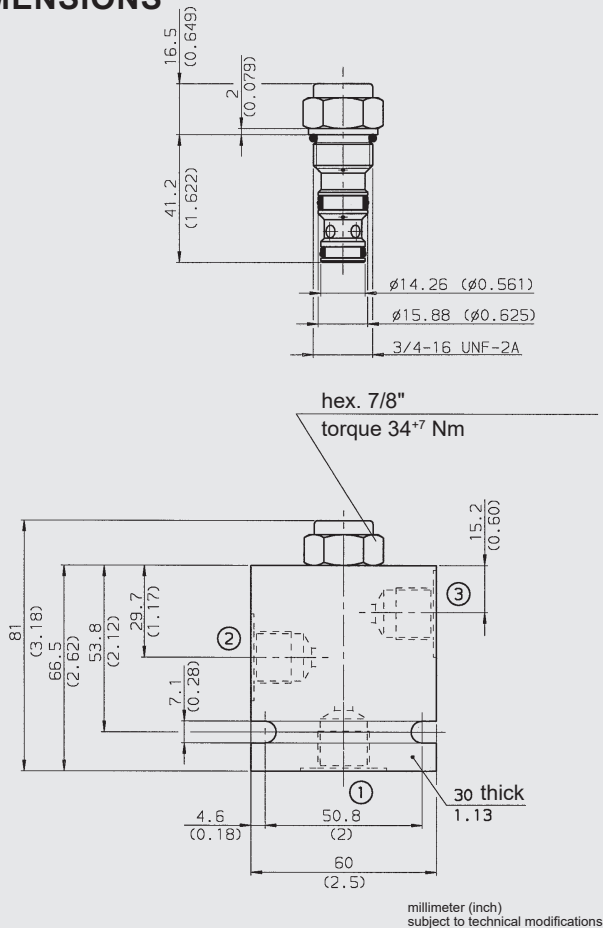

MODEL CODE

RP08A-01 - C - NS - 15- 4

Basic model _____
Check valve, pilot-to-open UNF

Body and ports* _____
C = cartridge only
SB3 = G3/8" ports, steel body
AB3 = G3/8" ports, aluminium body

Seals _____
N = NBR
NS = NBR with piston seal
V = FKM
VS = FKM with piston seal

Cracking pressure _____
15 = 1 bar (15 PSI)

Pilot ratio _____
3 = 3:1
4 = 4:1

Standard models

Model code	Part No.
RP08A-01-C-N-15-3	561916
RP08A-01-C-N-15-4	561918
RP08A-01-C-NS-15-3	561917
RP08A-01-C-NS-15-4	561919

Other models on request

*Standard in-line bodies

Code	Part No.	Material	Ports	Pressure
FH083-SB3	560922	Steel, zinc-plated	G3/8"	350 bar
FH083-AB3	3011427	Aluminium, anodized	G3/8"	210 bar

Other models on request

Seal kits

Code	Part No.
FS UNF 08/N	3651385
FS UNF 08/V	3651356

CAVITY

FC08-3

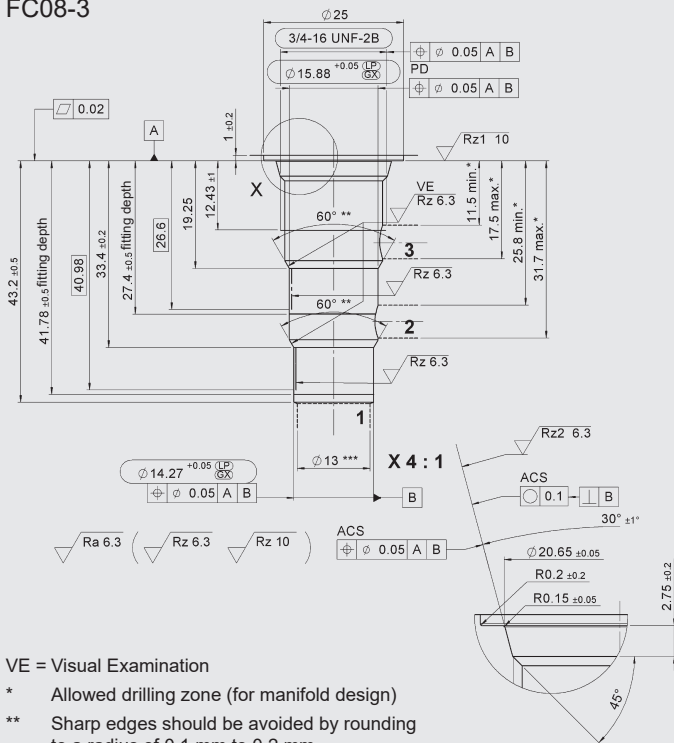

VE = Visual Examination

* Allowed drilling zone (for manifold design)

** Sharp edges should be avoided by rounding to a radius of 0.1 mm to 0.2 mm

*** largest pre-drilling diameter (nominal tool diameter)

Form tools

Tool	Part No.
Countersink	175644
Reamer	175645

millimeter (inch)
subject to technical modifications

TYPICAL PERFORMANCE

phi=3:1 measured at $v = 34 \text{ mm}^2/\text{s}, T_{oil} = 46 \text{ }^\circ\text{C}$

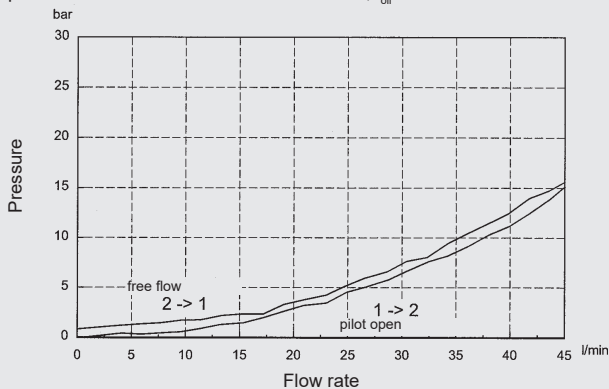

phi=4:1 measured at $v = 34 \text{ mm}^2/\text{s}, T_{oil} = 46 \text{ }^\circ\text{C}$

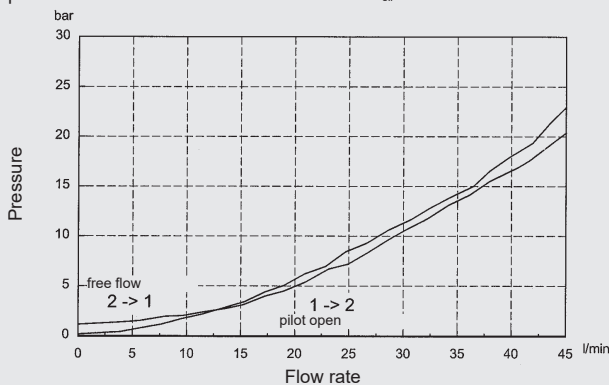

NOTE

The information in this brochure relates to the operating conditions and applications described. For applications or operating conditions not described, please contact the relevant technical department. Subject to technical modifications.

HYDAC Fluidtechnik GmbH

Justus-von-Liebig-Str.
D-66280 Sulzbach/Saar
Tel: 0 68 97 /509-01
Fax: 0 68 97 /509-598
E-Mail: valves@hydac.com