

2-way flow control valve with sliding throttle type SB and SQ

Screw-in valves for tapped holes
Versions with housing

Operating pressure $p_{max} = 315$ bar
Flow $Q_{max} = 400$ lpm

Design, not adjustable after installation

Screw in version

Type SB..C
SQ..C

Cartridge version

Type SB..G
SQ..G

Type SB..E
SQ..E

Type SB..F
SQ..F

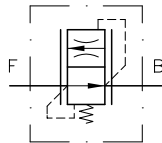
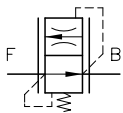

Design, adjustable after installation

Screw in version

Type SB..H
SQ..H

Cartridge version with swivel housing

Type SB..H 6 (...20)
SQ..H 6 (...20)

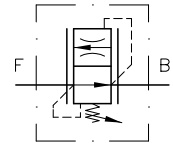
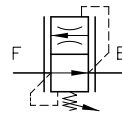

1. General information

These 2-way flow control valves (drop-rate braking valves) type SB and SQ restrict the flow down to the set figure rather independent of the respective load pressure. A large cross section area is opened up in reverse flow direction via the patented sliding throttle (see below). This way, an otherwise necessary by-pass check valve to minimize the back pressure, is superfluous.

With all other conventional designs, using fixed metering orifices, the smaller the regulated flow (i.e. the smaller the metering orifice required), the greater the flow resistance will become.

They consist basically of a cylinder liner (housing) with control piston and piston spring, plus a freely-movable metering orifice disk (patented sliding throttle). This is brought into the operational pos. (control position) by the flow medium, and forms an annular orifice in the control piston. The flow resistance of this orifice, in conjunction with the preloading (setting length) of the piston spring, determines the magnitude of the regulated flow. In the opposite direction, the orifice moves completely out of the control position, the metering orifice (annular orifice) is raised up, and flow is possible completely independent of any setting range and with minimum resistance (check valve effect).

Difference between type SB and SQ:

Type SB

Use at lifting devices with positive load, featuring an oscillation damping, where the Δp - Q curve is slightly angled in load direction

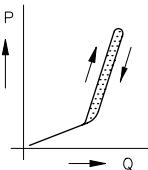

Type SQ

Use in hydraulic systems without a tendency to oscillations, e.g. to limit the speed of double acting cylinders

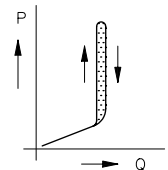

Function :

Working direction $F \leftarrow B$

Flow rate substantially constant as a result of the equilibrium automatically obtained between the internal pressure gradient and the pre-load of the piston valve spring

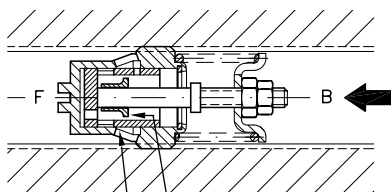

Control edges

Sliding throttle in controlled flow direction

Opposite direction $F \rightarrow B$

Free, unimpeded flow with minimal resistance through the sliding throttle which slides back out of the regulating position (thus cancelling the effect of the orifice)

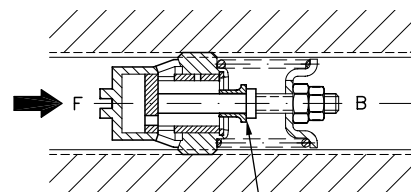

Sliding throttle in free flow direction

2. Types available, main data

2.1 Version non adjustable when installed

Operating pressure $p_{max} = 315 \text{ bar}$.

Preferably for setting once only. Not accessible from outside when installed and accordingly completely protected against unauthorized adjustments.

Order example: Standard design **SB 2 1 C - 20**

Version with metric thread **SB 2 5 22 C - 30**

Version with thread reduction ring **SB 3/2 3 G - 28**

Required response flow in lpm, within setting range, preset at HAWE (see also section 3.3)

	Connection 1)	Basic type and size	Coding for setting range; below adjustable response flow from... to... (lpm) 5)						Additional coding for thread
			1	3	5	7	9	90	
Standard version for pipe connection, conforming DIN ISO 228/1 (BSPP)	G 1/4 (A)	SB 0	1 1.6	1.6 2.5	2.5 4	4 6.3	6.3 10	10 15	
	G 3/8 (A)	SB 1 SQ 1	2.5 4	4 6.3	6.3 10	10 16	16 25	25 35 2)	
	G 1/2 (A)	SB 2 SQ 2	16 21	21 28	28 37	37 50	50 67 2)		
	G 3/4 (A)	SB 3 SQ 3	37 50	50 67	67 90	90 120	120 150 2)		
	G 1 (A)	SB 4	80 100	100 125	125 160	160 200	200 250		
	G 1 1/4 (A)	SB 5	170 200	200 236	236 280	280 335	335 400		
Version for metric fine thread, conforming DIN 13 T6	M 14x1.5	SB 0	1 1.6	1,6 2.5	2.5 4	4 6.3	6.3 10	10 15	14
	M 16x1.5	SB 1	2.5 ...	4 ...	6.3 ...	10 ...	16 ...	25 ...	16
	M 18x1.5	SQ 1	... 4	... 6.3	... 10	... 16	... 25	... 35 2)	18
	M 20x1.5	SB 2	16 ...	21 ...	28 ...	37 ...	50 ...		20
	M 22x1.5	SQ 2	... 21	... 28	... 37	... 50	... 67 2)		22
	M 27x2	SB 3 SQ 3	37 50	50 67	67 90	90 120	120 150 2)		27
	M 33x2	SB 4	80 100	100 125	125 160	160 200	200 250		33
M 42x2	SB 5	170 200	200 236	236 280	280 335	335 400		42	
3)	7/8 14 UNF	SB 2	16 21	21 28	28 37	37 50	50 67		7/8 - 14 UNF
Version for thread reduction ring only for threads, conforming DIN ISO 228/1 (BSPP)	G 3/8 (A)	SB 1/0	1 1.6	1.6 2.5				6920 151	Order coding for thread reduction ring as single component
	G 1/2 (A)	SB 2/1 SQ 2/1	2.5 4	4 6.3	6.3 10	10 16		6920 152	
	G 3/4 (A)	SB 3/2 SQ 3/2	16 21	21 28	28 37			6920 153	
	G 1 (A)	SB 4/3 SQ 4/3	37 50	50 67	67 90			7227 020	
	G 1 1/4 (A)	SB 5/4	80 100	100 125	125 160	160 200		7227 070	

Design version

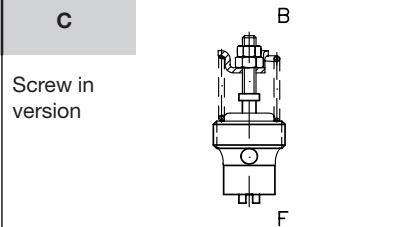

Version with housing for pipe connection 3) 4)

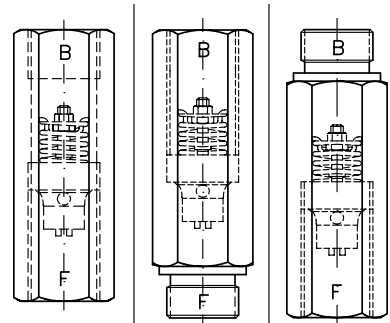

Screw-in cartridges size 0 to 4 with thread reduction ring, screwed into the next larger housing size 1 to 5.
Application example:
Adapting to the connection size of the hydraulic devices being used.
Example: SB 3/23 G-...

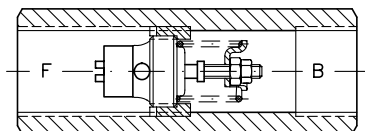

1) G...A with tapped journal; G... with tapped ports
2) Only available as type SB..

3) UNF-thread conf. SAE J 514, is only available with design codings C, E, and F
4) Version with metric thread available only as size 1 and 2 with design coding G, E and F
5) corresponds to a set pressure of 50 bar, see sect. 3.2 „Nom. flow”

2.2 Version, adjustable when installed

Note: These versions are externally adjustable and may be additionally blocked (only type SB..K..., see appendix in sect. 5.2)!

Operating pressure $p_{max} = 315$ bar.

After releasing a locknut, the actuation flow can be adjusted within the given limits along a specific adjustment path S (see sect. 3.3).

The screw-in cartridges are located in a swiveling housing (corner valve), at versions with housing.

Order example: Banjo bolt version ²⁾

SB 3 9 H - 130

Version with swivel housing (standard, suited for BSPP pipe fittings)

SB 1 7 H 12 - 14

Version with swivel housing (special version featuring metric thread)

SB 2 5 22 H 16 - 30

Required response flow in lpm within setting range, present at HAWE

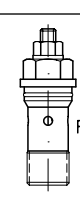
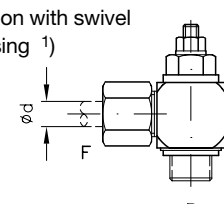
	Connection ¹⁾	Basic type and size	Coding for setting range; below adjustable response flow from... to... (lpm) ⁵⁾						Additional coding for thread	Design version																				
			1	3	5	7	9	90																						
Standard version with threads DIN ISO 228/1 (BSPP)	G 1/4 (A)	SB 0 SQ 0	11.6 ⁴⁾	1.62.5 ⁴⁾	2.54 ⁴⁾	46.3	6.310	1015 ⁴⁾	X	H Banjo bolt version ²⁾ 																				
	G 3/8 (A)	SB 1 SQ 1	2.54 ⁴⁾	46.3 ⁴⁾	6.310	1016	1625 ⁴⁾	2535 ⁴⁾																						
	G 1/2 (A)	SB 2 SQ 2	1621	2128	2837	37... ...50	5067 ⁴⁾	X		Version with swivel housing ¹⁾ 																				
	G 3/4 (A)	SB 3 SQ 3	3750	5067	6790	90... ...120	120150 ⁴⁾																							
Version with metric fine thread DIN 13 T6	M 14x1.5	SB 0	11.6	1.62.5	2.54	46.3	6.310	1015	14	<table border="1"> <thead> <tr> <th>Suited for</th> <th>Coding</th> <th>Ød</th> </tr> </thead> <tbody> <tr> <td rowspan="2">SB 0 SQ 0</td> <td>H 6 ³⁾</td> <td>6</td> </tr> <tr> <td>H 8</td> <td>8</td> </tr> <tr> <td></td> <td>HL 10</td> <td>10</td> </tr> <tr> <td>SB 1 SQ 1</td> <td>H 12</td> <td>12</td> </tr> <tr> <td>SB 2 SQ 2</td> <td>H 16</td> <td>16</td> </tr> <tr> <td>SB 3 SQ 3</td> <td>H 20</td> <td>20</td> </tr> </tbody> </table>	Suited for	Coding	Ød	SB 0 SQ 0	H 6 ³⁾	6	H 8	8		HL 10	10	SB 1 SQ 1	H 12	12	SB 2 SQ 2	H 16	16	SB 3 SQ 3	H 20	20
	Suited for	Coding	Ød																											
	SB 0 SQ 0	H 6 ³⁾	6																											
		H 8	8																											
	HL 10	10																												
SB 1 SQ 1	H 12	12																												
SB 2 SQ 2	H 16	16																												
SB 3 SQ 3	H 20	20																												
M 18x1.5	SB 1	2.54	46.3	6.310	1016	1625	2535	18																						
M 22x1.5	SB 2	1621	2128	2837	37... ...50	5067	X	22																						
M 27x2	SB 3	3750	5067	6790	90... ...120	120150		27																						

1) DIN ISO 228/1 (BSPP), G...A with tapped journal; G... for tapped ports

2) Banjo bolt version to be installed in customer furnished valve body, see mounting hole dimensions in sect. 4.2. It is also possible to convert this version to one with swivel housing H 6 ... H 20. The necessary parts are listed below.

3) Not available for versions featuring metric fine thread

4) Only available as type SB..

5) corresponds to a set pressure of 50 bar, see sect. 3.2 „Nom. flow”

Individual fitting parts for conversion SB...H into SB...H 6 to H 20

Type	Individual part designation			
	Housing, W-type	Seal ring	Union nut	Cutting edge
SB(Q) 0 .. H 6	XWH 6 - SR - CFX	KDS 14 A3CX	m 6 - S - CFX	PSR 06 - L/X
SB(Q) 0 .. H 8	XWH 8 - SM/SR - CFX	KDS 14 A3CX	m 8 - S - CFX	PSR 08 - L/X
SB(Q) 0 .. HL 10	XWH 10 - LR - CFX	KDS 14 A3CX	m 10 - L - CFX	PSR 10 - L/X
SB(Q) 1 .. H 12	XWH 12 - SR - CFX	KDS 16 A3CX	m 12 - S - CFX	PSR 12 - L/X
SB(Q) 2 .. H 16	XWH 16 - SR - CFX	KDS 22 A3CX	m 16 - S - CFX	PSR 16 - L/X
SB(Q) 3 .. H 20	XWH 20 - SM/SR - CFX	KDS 27 A3CX	m 20 - S - CFX	PSR 20 - L/X

3. Characteristic data

3.1 General

Nomenclature and design	Flow valve (drop-rate flow control valve) in piston spool design
Flow direction	B → F controlled (limited) flow F → B free flow
Pipe connection	Depending on type (see sect. 2.1 and 2.2) Threads conforming DIN ISO 228/1 (BSPP), metric fine thread DIN 13 T6, UNF thread conforming SAE J 514
Installation position	Any
Mounting	SB...C; SQ...C (cartridge) is clamped at the end of the thread when tightened with the correct torque (see sect. 4.1) SB...G; SQ...G (screw-in cartridge with housing) mounted any place in the pipe system SB...E, F and H...; SQ...E, F and H (screw-in cartridge with housing) mounted in the device housing

Mass (weight) approx. g	Basic type	SB 0..	SB 1..	SB 2..	SB 3..	SB 4..	SB 5..
		SQ 0..	SQ 1..	SQ 2..	SQ 3..		
	Cartridge C	13	23	40	80	150	300
	With housing E, F, G	130	150	250	550	800	1650
	Banjo bolt version SB...H, SQ...H	50	110	180	270	---	---
With swivel housing SB..H 6 to H 20 SQ..H 6 to H 20	140	250	470	770	---	---	

3.2 Hydraulic

Operating pressure	approx. 15 ... 315 bar
Setting range	see section 2
Pressure fluid	Hydraulic oil conforming DIN 51524 part 1 to 3: ISO VG 10 to 68 conforming DIN 51519. Viscosity limits: min. approx. 4, max. approx. 1500 mm ² /s, Opt. operation approx. 10 ... 500 mm ² /s. Also suitable for biological degradable pressure fluids types HEPG (Polyalkylenglycol) and HEES (Synth. Ester) at service temperatures up to approx. +70°C.
Temperature	Ambient: approx. -40 ... +80°C Fluid: -25 ... +80°C, Note the viscosity range ! Permissible temperature during start: -40°C (Note start-viscosity!), as long as the service temperature is at least 20K higher for the following operation. Biological degradable pressure fluids: Note manufacturer's specifications. By consideration of the compatibility with seal material not over +70°C.
Nominal flow	Factory set for a load pressure Δp = 50 bar, see also sect. 3.3 The adjustment tolerance depends on size and adjustment range; Guideline approx. ± 25 % (SB 0.., SQ...) to ± 7 % (bigger versions)

Δp-Q-characteristic curves

(in free flow direction F → B)

Oil viscosity during measurement approx. 60 mm²/s

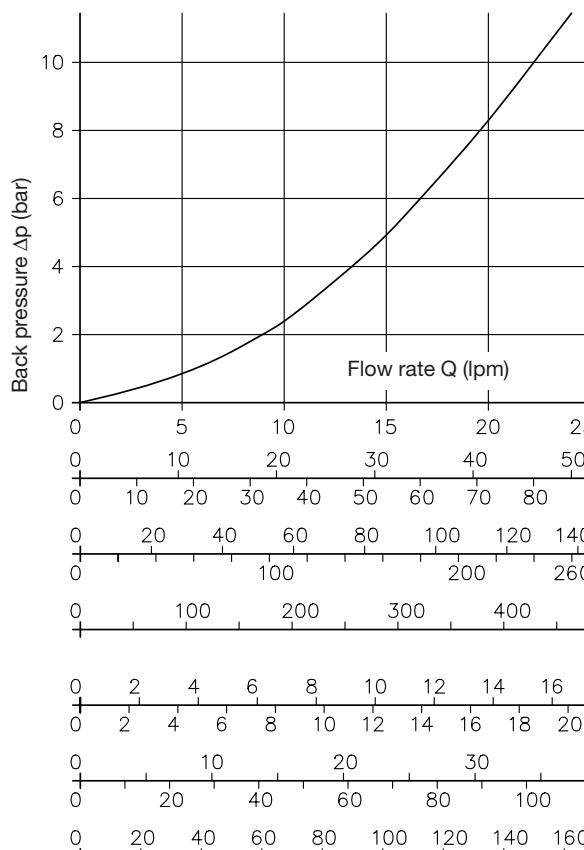

SB 0, SB 1/0...
SB 1, SB 2/1...; SQ 1, SQ 2/1
SB 2, SB 3/2...; SQ 2, SQ 3/2
SB 3, SB 4/3...; SQ 3, SQ 4/3
SB 4, SB 4/4...
SB 5
SB 0..H 6; SQ 0..H 6
SB 0..H 8; SQ 0..H 8
SB 1..H 12; SQ 2..H 12
SB 2..H 16; SQ 2..H 16
SB 3..H 20; SQ 3..H 20

3.3 Adjustment characteristic

Response flow type SB (operat. direction B → F)

The response flow is set at HAWE at an operating pressure of 50 bar. When the characteristic is completely pressure-dependent (vertical), oscillations can occur on lifting equipment as a result of the elasticity of the oil volume in the lifting cylinder and hoses. In the case of the drop-rate brakes SB, the characteristic is therefore set with a slight incline, which allows such possible oscillations to be effectively suppressed. If you wish the desired actuating flow (set value) to be reached under a different pressure load, this pressure must be specified additionally to the order coding. The works setting is then made at this pressure, which then also appears in the type description on the valve housing in addition to the actuating flow value, e.g. SB 25 G -30/150 (30 lpm at 150 bar)

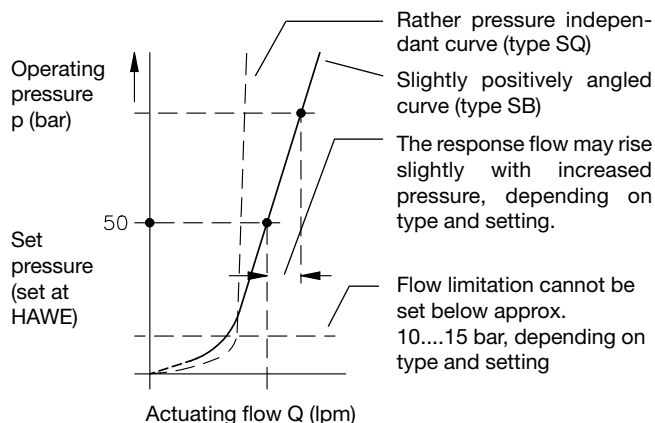

Changing the setting length S

The setting length S is only a guideline figure for the response flow at $\Delta p_{B \rightarrow F} = 50$ bar, see also curves on page 6. For altering the setting within the range (table in sect. 2) follow the instructions below.

● Clamping

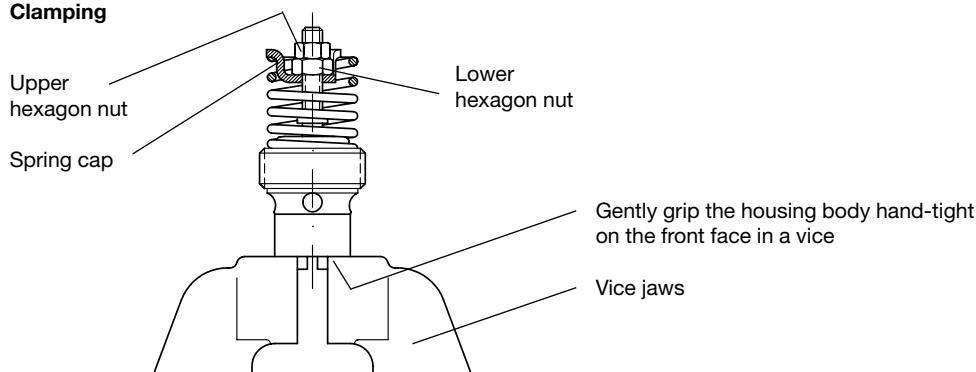

● Adjustment

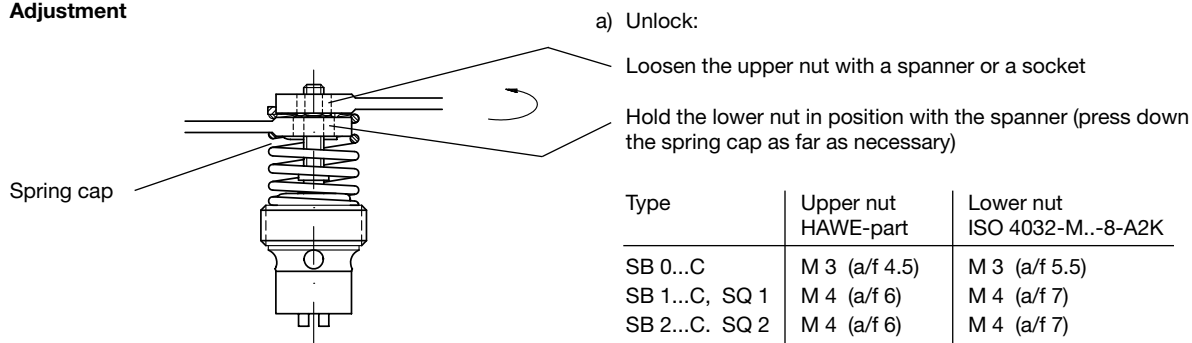

Type	Upper nut HAWE-part	Lower nut ISO 4032-M...-8-A2K
SB 0...C	M 3 (a/f 4.5)	M 3 (a/f 5.5)
SB 1...C, SQ 1	M 4 (a/f 6)	M 4 (a/f 7)
SB 2...C, SQ 2	M 4 (a/f 6)	M 4 (a/f 7)
SB 3...C, SQ 3	M 4 (a/f 6)	M 4 (a/f 7)
SB 4...C	M 5 (a/f 7)	M 5 (a/f 8)
SB 5...C	M 6 (a/f 9)	M 6 (a/f 10)

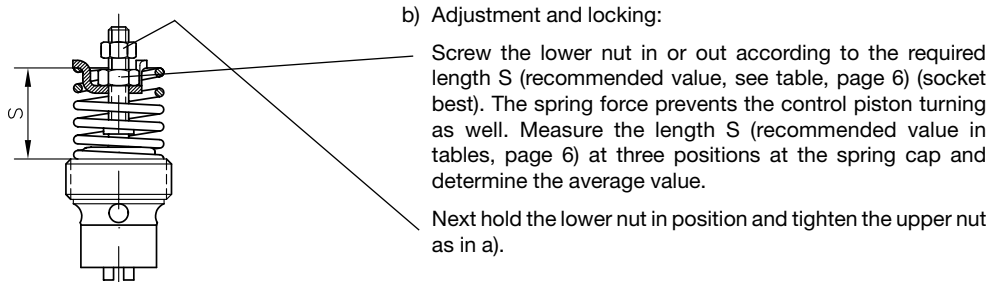

For adjustment control, see continuation on page 6!

● **Checking the adjustment**

Reinstall the flow control valve in the circuit and check the newly adjusted flow. When the new setting is correct a mark should be put on the rod thread 3 d with a center punch just above the lock nut to prevent loosening. Observe the correct torque for the valve in sect. 4.1 !

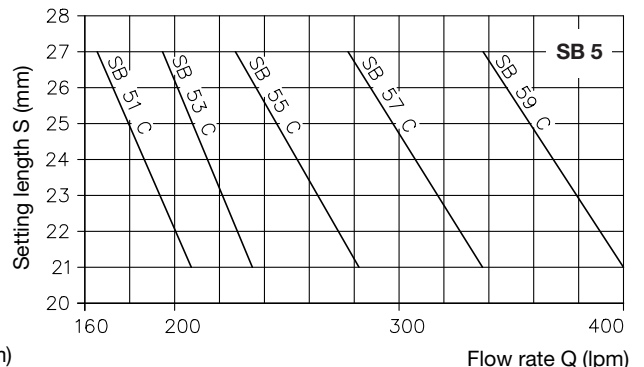
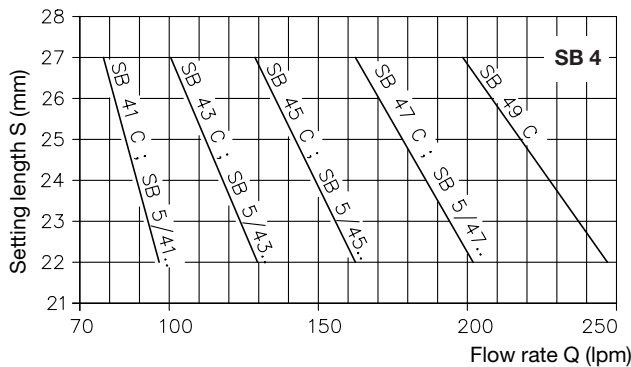
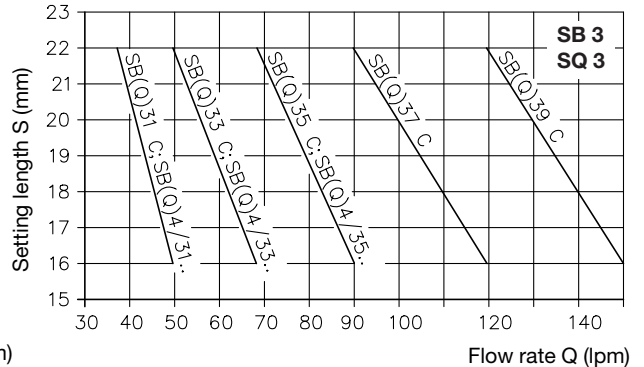
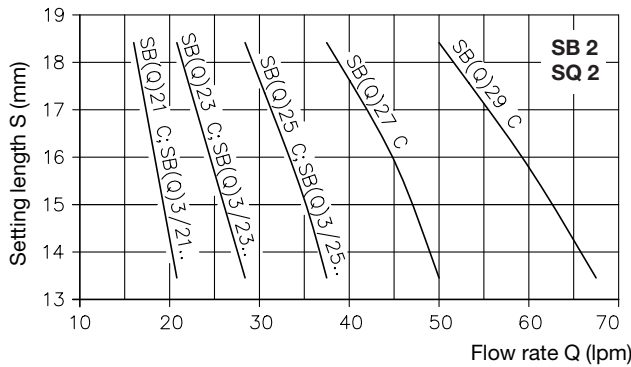
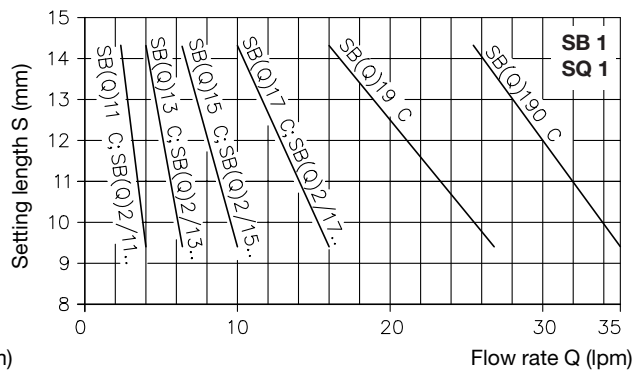
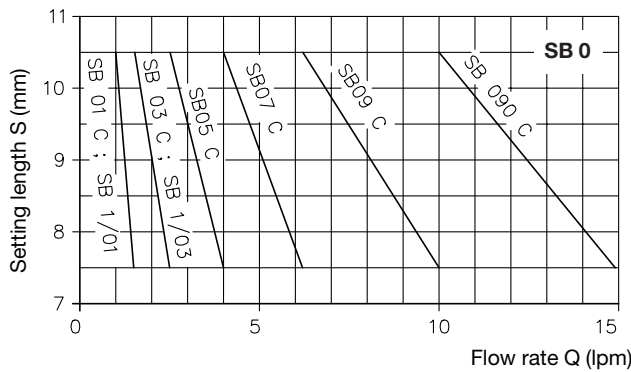

Banjo bolt version SB...H and SQ...H

Adjustment of the response flow is carried out at the threaded spindle within the particular range, using an allen key 3 mm, after loosening the Seal-Lock locknut.

Caution: Do not screw out the threaded spindle out of the housing beyond the dimension S_{max} , because there is no internal stop provided. This note should be included in the setting instructions in the operating manual.

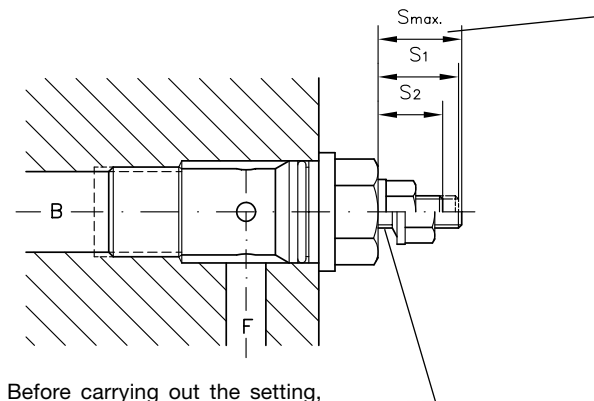

Before carrying out the setting, loosen the lock nut sufficiently for the integrally-vulcanized sealing ring to be free.

do not exceed this value !

Setting lengths

Type	S_{max}	S_1	S_2
SB 0...H; SQ...	12	10 ... 11	7 ... 9.5
SB 1...H; SQ...	13	11 ... 12	7.5 ... 9.5
SB 2...H; SQ...	13	9.5 ... 11	7 ... 8.5
SB 3...H; SQ...	14	11.5 ... 13	7 ... 9.5

Approximate guideline values

- S_1 approx. corresponds to the lower and
- S_2 approx. to the upper limit value of the response flow of each particular setting range. See table under section 2.2

4. Dimensions

All dimensions are in mm, subject to change without notice!

4.1 Version non adjustable when installed (acc. to section 2.1)

Cartridge version

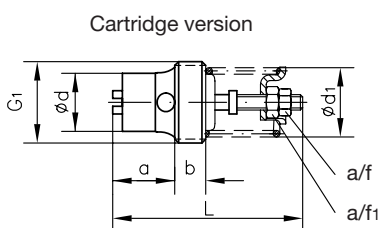

Location hole (see also example sect. 5.1)

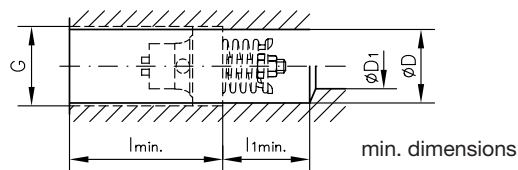

Type	G1	L	a	b	d	d1	a/f	a/f1	G	D	D1	l _{min}	l _{1min}	Torque (Nm)
SB 0	G 1/4 A M 14x1.5	39	12.5	7	10	10.5	4.5	5.5	G 1/4 M 14x1.5	11.75	5	33	22	6
SB 1 SQ 1	G 3/8 A M 16x1.5 M 18x1.5	43	13.5	7	11.5	13.5	6	7	G 3/8 M 16x1.5 M 18x1.5	15.25	8	34	26	8
SB 2 SQ 2	G 1/2 A M 20x1.5 M 22x1.5 7/8-14 UNF-2B	49	16	8	15	18	6	7	G 1/2 M 20x1.5 M 22x1.5 7/8-14 UNF-2A	19	12	40	30	12
SB 3 SQ 3	G 3/4 A M 27x2	61	21	10	20	23	6	7	G 3/4 M 27x2	24.5	16	51	29	15
SB 4	G 1 A M 33x2	78	25	15	26	28.5	7	8	G 1 M 33x2	30.5	20	65	40	20
SB 5	G 1 1/4 A M 42x2	94	31	21	33	34.5	9	10	G 1 1/4 M 42x2	39.5	25	78	42	25

Max. torque for cartridge version retaining borehole, provided by client, and in valve housing

Housing design

Design E and F

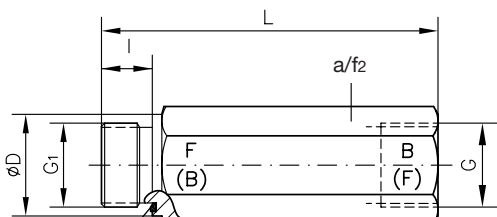

Design G

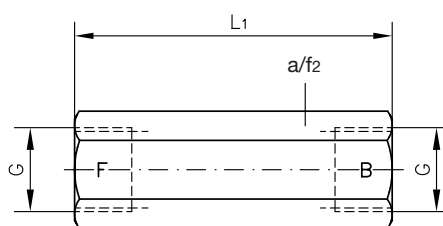

Seal : G 1/4 NBR (SB 0..E and F)

- 1) DRV 100 147 - NB 650 (SB 1..E and F; SQ 1..E and F)
- DRV 100 185 - NB 650 (SB 2..E and F; SQ 2..E and F)
- DRV 100 239 - NB 650 (SB 3..E and F; SQ 3..E and F)
- DRV 100 297 - NB 650 (SB 4..E and F)
- DRV 100 388 - NB 650 (SB 5..E and F)

- 1) With type SB 2..E(F) -7/8 14 UNF cutting edge

- 2) G...(A) Δ BSPP

Type	G	G1	D	L	L1	l	a/f2
SB 0..E (F, G)	G 1/4	G 1/4 A	19	78	66	11.5	19
SB 1.. E (F, G) SQ 1.. E (F, G)	G 3/8 M 16x1.5	G 3/8 A M 16x1.5	22	82	70	12	22
	M 18x1.5	M 18x1.5					24
SB 2.. E (F, G) SQ 2.. E (F, G)	G 1/2 M 20x1.5	G 1/2 A M 20x1.5	27	96	80	14	27
	M 22x1.5	M 22x1.5					30
	7/8-14 UNF-2B	7/8-14 UNF-2A					--
SB 3.. E (F, G) SQ 3.. E (F, G)	G 3/4	G 3/4 A	32	106	100	16	32
SB 4.. E (F, G)	G 1	G 1 A	40	145	125	18	41
SB 5.. E (F, G)	G 1 1/4	G 1 1/4 A	50	160	145	20	50

4.2 Version, adjustable when installed (acc. to section 2.2)

Banjo bolt version

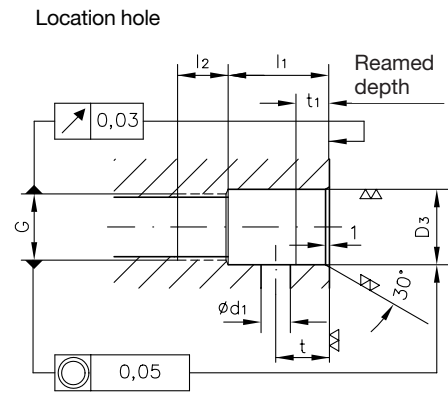
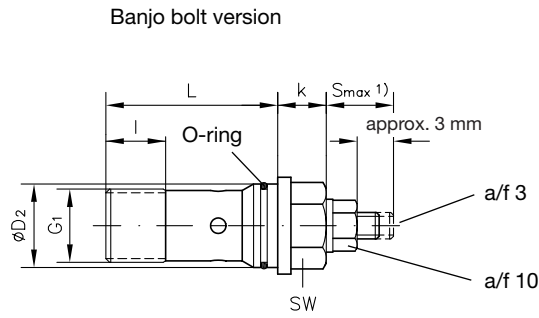

Caution: Do not screw the threaded rod out of the housing beyond the specified dimension S_{max} , as there is no internal stop !

Type	G ₁ ³⁾	D ₂	L	k	l	a/f		O-ring NBR 90 Shore	G ³⁾	D ₃	d ₁	l ₁	l ₂	t	t ₁
						Torque max. (Nm)									
SB(Q) 0..H	G 1/4 A	15.45	35	8	12	13	50	12.5x1.5	G 1/4	15.5 +0.1	5	23	13	12	5
SB(Q) 0..14 H	M 14x1.5								M 14x1.5						
SB(Q) 1..H	G 3/8 A	18.95	39	11	12	17	75	16x1.5	G 3/8	19 +0.1	8	27	13	13	8
SB(Q) 1..18 H	M 18x1.5								M 18x1.5						
SB(Q) 2..H	G 1/2 A	22.95	49.5	12.5	15	19	130	20x1.5	G 1/2	23+0.1	12	35	15	16	12
SB(Q) 2..22 H	M 22x1.5								M 22x1.5						
SB(Q) 3..H	G 3/4 A	28.95	59.5	14.5	20.5	24	250	25x2	G 3/4	29 +0.1	16	43	18	20	10
SB(Q) 3..27 H	M 27x2								M 27x2						

Housing design (Cartridge version with swivel housing)

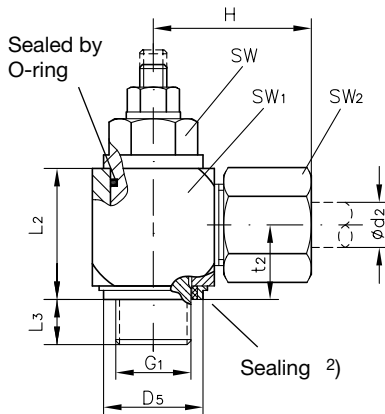

Type	G ₁ ³⁾	L ₂	L ₃	H	D ₅	t ₂	d ₂
SB(Q) 0..H 6	G 1/4 A	24	11	31	18.9	14	6
SB(Q) 0..H 8	G 1/4 A	24	11	31	18.9	14	8
SB(Q) 0..14 H 8	M 14x1.5	24			18.9		
SB(Q) 0..HL 10	G 1/4 A	24	12	35	18.9	14	10
SB(Q) 1..H 12	G 3/8 A	27			21.9	16.5	12
SB(Q) 1..18 H 12	M 18x1.5	32	11	35	23.9	18.5	
SB(Q) 2..H 16	G 1/2 A	34.5	15	40	26.9	21.5	16
SB(Q) 2..22 H 16	M 22x1.5	31	14		26.9		
SB(Q) 3..H 20	G 3/4 A	43.5	16	48	32.9	24	20
SB(Q) 3..27 H 20	M 27x2	40			32.9		

Location hole

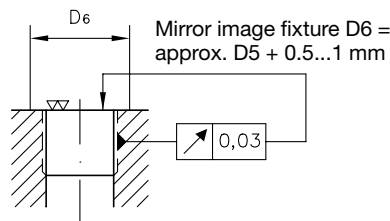

Type	a/f ₁	a/f ₂	a/f	Torque max. (Nm)
SB(Q) 0..H 6	22	17	13	50
SB(Q) 0..H 8	22	19	13	50
SB(Q) 0..14 H 8				
SB(Q) 0..HL 10				
SB(Q) 1..H 12	27	24	17	75
SB(Q) 1..18 H 12	30			
SB(Q) 2..H 16	32	30	19	130
SB(Q) 2..22 H 16				
SB(Q) 3..H 20	41	36	24	250
SB(Q) 3..27 H 20		30		

For missing dimensions, see above !

1) S_{max} = 12 ... 14 depending on type see sect 3.3

2) Sealing by plastic seal ring type KDS, must be replaced when valve is remounted.

3) G...(A) ≙ BSPP

5. Appendix

5.1 Example circuits

Used as drop-rate braking valve

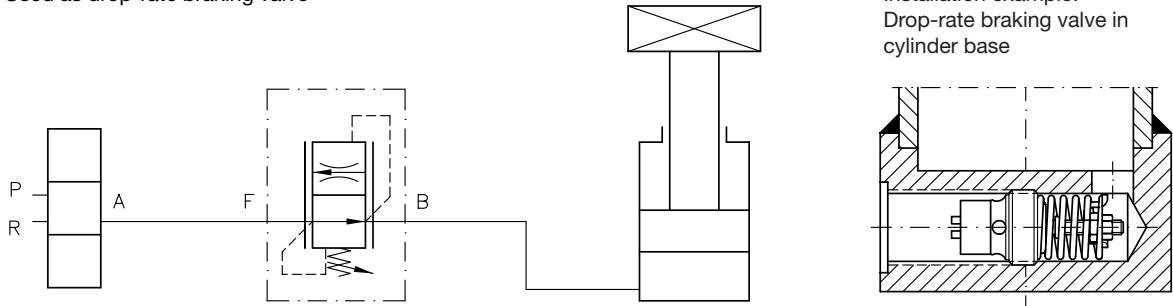

Installation example:
Drop-rate braking valve in
cylinder base

5.2 Version with housing, that can be adjusted and locked externally

Version

- The control piston of the drop-rate braking valve can be blocked via the set-screw for functional tests of line rupture safety valves in the circuit (e.g. stackers). This cuts-off the control function of the drop-rate braking valve and enables unhindered flow B, C, D → A.
- The curve of the standard version is positively angled to prevent oscillations of the cylinder during downward movement. This means the resulting flow will be higher in the area of p_{max} than adjusted (setting is for 50 bar at HAWE if not specified otherwise)
- This curve can be more or less erected with different piston/orifice combinations (e.g. type SB 275 K). Attention: It has to be checked whether undesired oscillations do occur at the respective application.

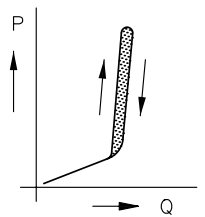

Order examples:

SB 2 7 K
SB 275 K

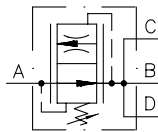

	Connections A, B, C, D DIN ISO 228/1 (BSPP)	Basic type and size	Coding for setting range; below adjustable response flow from... to... (lpm)					Housing versions	
			1	3	5	7	9	K	K1
			16 ... 21	21 ... 28	28 ... 37	37 ... 50	50 ... 67		
Standard	G 1/2	SB 2	●	●	●	●	●	●	●
	G 3/4	SB 3	●	●	●	●	●	●	
Special version	G 1/2	SB 23	●					●	●
		SB 25		●				●	●
		SB 27			●			●	●
		SB 29				●		●	●
	G 3/4	SB 33	●					●	
		SB 35		●				●	
		SB 37			●			●	
		SB 39				●	●		

Operating pressure

$p_{max} = 315$ bar

Flow direction

A → B, C, D free flow
B, C, D → A controlled (limited) flow

Mounting

via thru-holes for lateral attachment

Mass (weight)

Type	SB 2..K	SB 2..K1	SB 3..K
approx. kg	1.4	1.2	1.5

Characteristic data

see section 3.1 and 3.2

Dimensions

All dimensions are in mm, subject to change without notice!

**Type SB 2..K
SB 3..K**

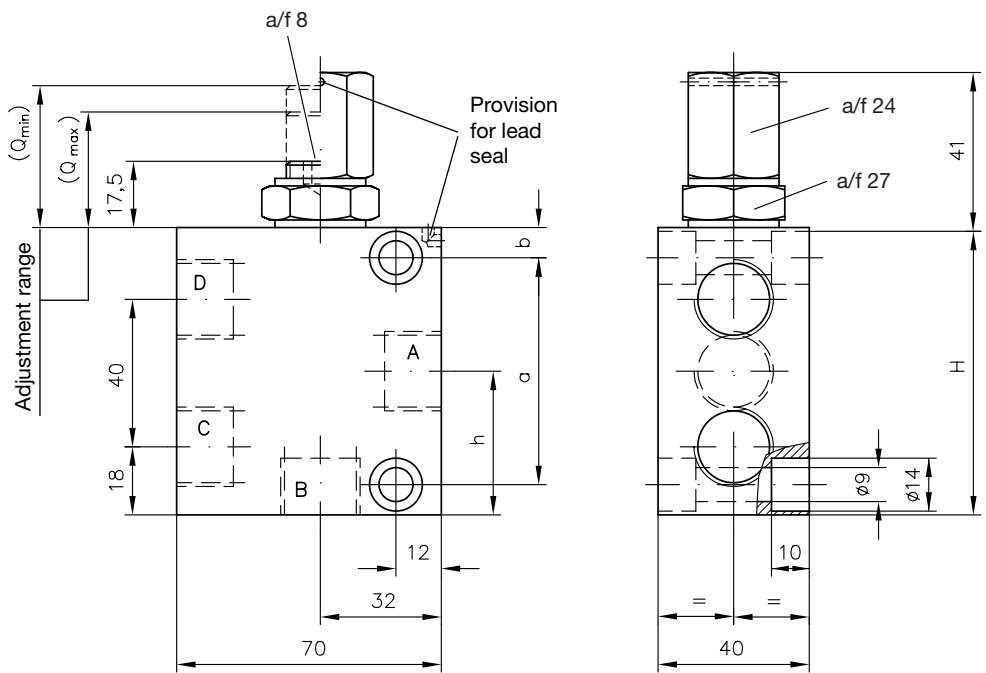

Type	Ports A, B, C, D DIN ISO 228/1 (BSPP)	H	a	b	h
SB 3..K	G 3/4	83	55	12	41

Type SB 2.. K 1

