

Flow control valves

Adjustable barrel type restrictors with ball type reverse flow check

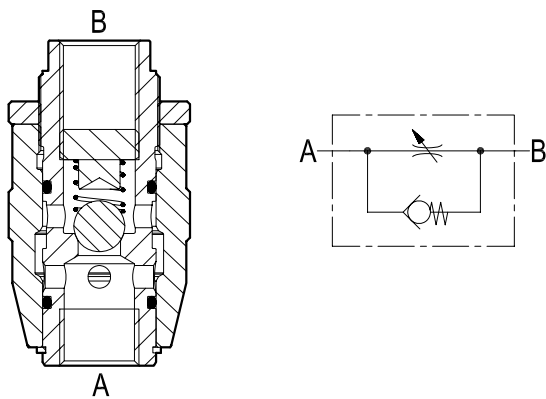

SU Series



Description

This line mounted restrictor throttles and limits the flow from B to A; it has an adjustable built-in restriction which can be tuned by rotating the external pinecone-type knurled sleeve from fully closed to fully open. Flow will increase by rotating the sleeve toward (+) direction. Once the desired adjustment is achieved, the sleeve can be locked by tightening the knurled ring nut (H) in order to prevent inadvertent changes or motion due to line vibrations. The maximum adjustment stroke is identified as K and, for different valve sizes, is shown by the specific table. This valve is a variable adjustable restriction, non-pressure-compensated: the actual flow through the valve will be determined by the pressure differential available between inlet B and outlet A, and also by the oil viscosity. The valve is available in different sizes for different flow ranges, as specified by the tables of the Technical data and Dimensions. Minor leakage "B-A" can be expected with valve fully closed. Free reverse flow "A-B" is always allowed through the incorporated poppet check valve with 0.5 bar cracking pressure.

Performance

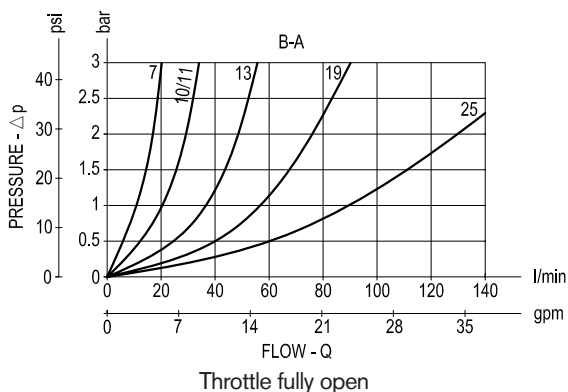
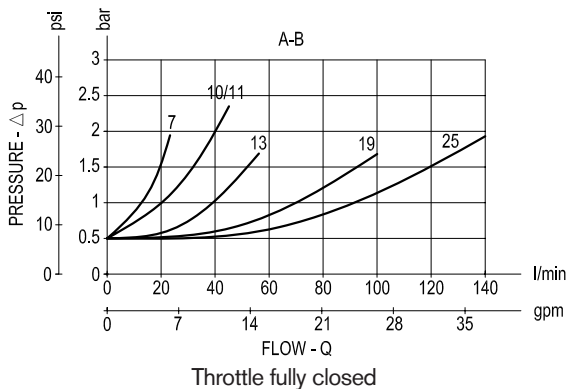

Technical data

Code	Pressure P max bar (psi)	Flow Q max l/min (gpm)	Weight kg (lbs)
SU 7	350 (5000)	12 (3)	0.30 (0.66)
SU 10	350 (5000)	30 (8)	0.40 (0.88)
SU 11	350 (5000)	30 (8)	0.40 (0.88)
SU 13	350 (5000)	45 (12)	0.70 (1.54)
SU 19	250 (3600)	80 (21)	1.12 (2.47)
SU 25	250 (3600)	140 (37)	3.0 (6.6)

Steel body, zinc plated

Dimensions

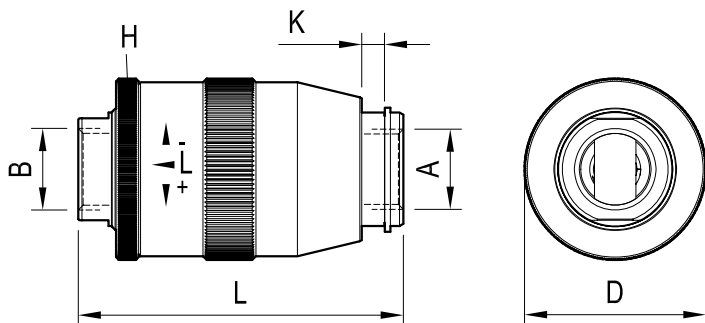

Ports size / Dimensions

Code	Ports size A-B	Ø D mm (inches)	L mm (inches)	K mm (inches)
SU 7	G 1/4	35 (1.38)	62 (2.44)	5 (0.20)
SU 10	G 3/8	38 (1.50)	72 (2.84)	7 (0.28)
SU 11	M 18x1.5	38 (1.50)	72 (2.84)	7 (0.28)
SU 13	G 1/2	48 (1.89)	86 (3.39)	8 (0.32)
SU 19	G 3/4	55 (2.17)	100 (3.94)	11 (0.43)
SU 25	G 1	79 (3.11)	126 (4.96)	12 (0.47)

Advantages

- Compact design and inline mounting for space saving.
- Six sizes provide great adaptability to the system.
- Easiness of adjustment.
- Mounting position is unrestricted.
- Low Δp in the free flow direction.

Applications

The SU Series valve is a fully and easily adjustable non-compensated flow control which can be employed for meter-in (Port A connected to the actuator inlet) or meter-out (Port B connected to the actuator outlet in order to control the oil flow from the actuator). The cost effectiveness and the easiness of adjustment make it suitable for many circuits and many applications where a non-compensated flow control is desired.

Ordering code



series 7	= 7
series 10	= 10
series 11	= 11
series 13	= 13
series 19	= 19
series 25	= 25

Cracking pressure (free flow) is always 0.5 bar (7.25psi)

Type	Material number	Type	Material number	Type	Material number
SU7	R932500602				
SU10	R932500603				
SU11	R932500604				
SU13	R932500605				
SU19	R932500606				
SU25	R932500607				