

SYMBOL

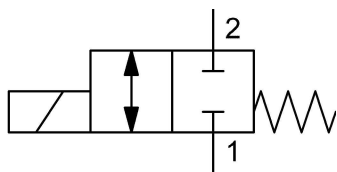

up to 10 l/min
up to 350 bar

2/2 Solenoid Directional Valve

Spool type, direct acting, Cartridge-Minivalve – 350 bar

WK06W-01

UNF

FUNCTION

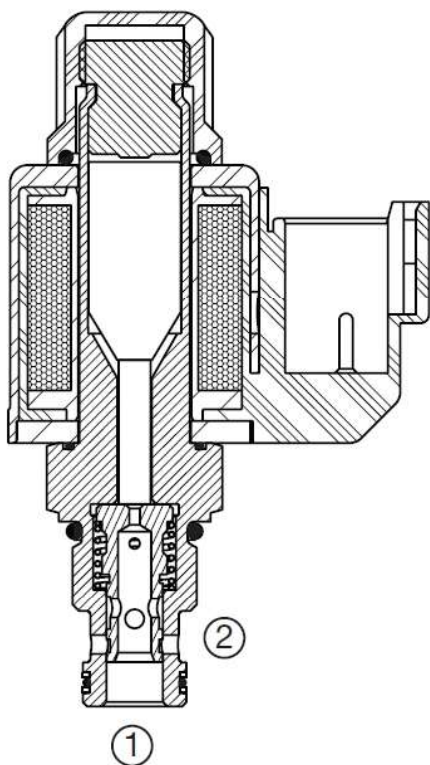

In de-energized mode the valve is blocked in both directions.
If energized, the valve opens and allows the flow in both directions.

FEATURES

- All exposed surfaces corrosion-proof
- All valve parts made of high-strength steel with hardened and ground components to ensure minimal wear and extended service life
- Coil seals protect the solenoid system
- Coil easy to exchange and pivotable

SPECIFICATIONS

Operating pressure:	max. 350 bar
Nominal flow:	max. 10 l/min
Leakage:	< max. 90 cm ³ /min at 207 bar and 28 mm ² /s
Temperature range of operating fluid:	Min. – 30°C up to max. +100° C
Ambient temperature range:	Min. – 30°C up to max. + 60° C
Fluid:	Hydraulic fluid to DIN 51524 T1 + T2
Viscosity range:	min. 7,4 mm ² /s up to max. 420 mm ² /s
Filtration:	Class 21 / 19 /16 according to ISO 4406 or cleaner
MTTFd:	150 years
Installation:	no orientation restrictions
Materials:	Valve body: steel with hardened work surfaces Piston: hardened and ground steel Seals: NBR (Standard) FKM (optional, temperature range -20°C up to +120°C)
Cavity:	Back-up rings: TPE-E
Weight:	FC06-2 Complete valve: 0,165 kg Coil only: 0,088 kg
Electrical data	
Type of voltage:	DC coil, AC voltage is rectified by a rectifier built-in the plug
Nominal current at 20°C:	984 mA at 12 V DC 492 mA at 24 V DC
Voltage tolerance:	+/- 15% of Coil voltage
Coil duty rating:	100% continuous up to max. 115% of Coil voltage at 60°C ambient temperature

DIMENSIONS

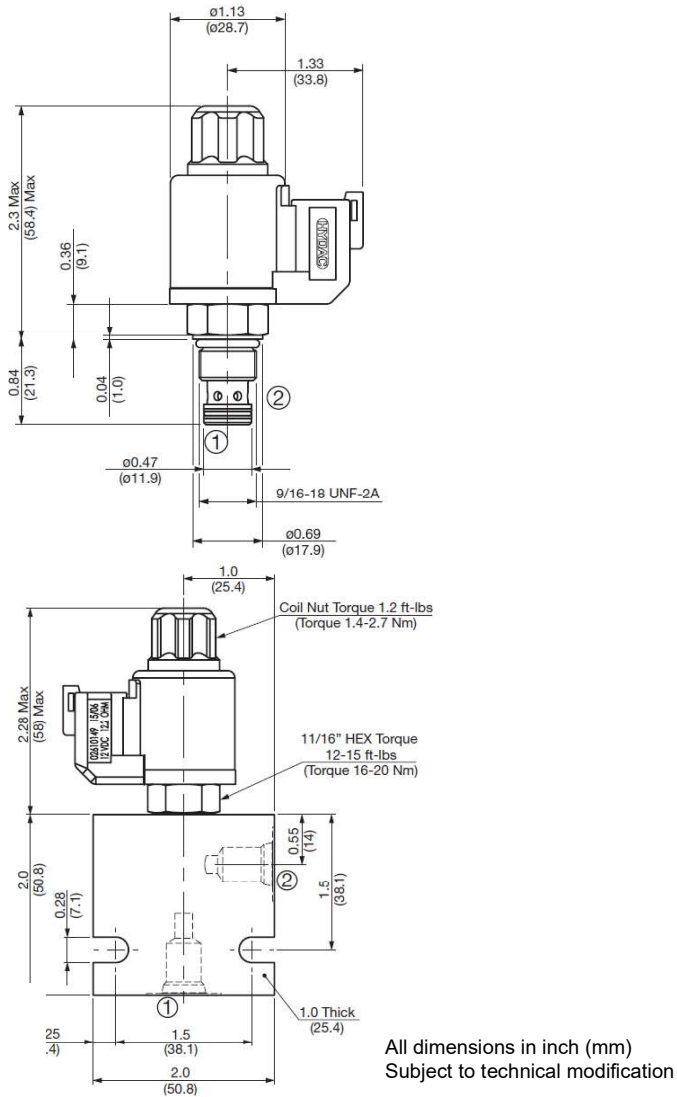

Cavity FC06-2

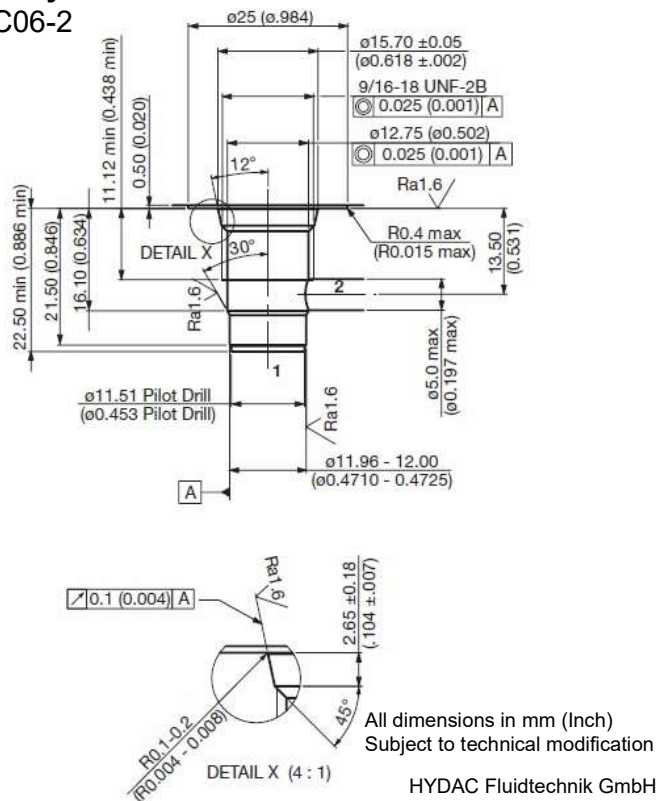

Tools

Code	Part No.
Twist drill	2582046
Countersink	2582047

HYDAC Fluidtechnik GmbH
Justus-von-Liebig-Str. 5
66280 Sulzbach / Saar
Tel.: 06897 / 509-0
Fax: 06897 / 509-598
Email: flutec@hydac.com

MODEL CODE

WK06W-01M-C-N-24 DN

Basic model _____
Directional Spool type, direct acting

Type _____
01 = Standard
01M = manual override

Body & ports _____
C = cartridge only
*versions in line bodies on request

Seals _____
N = NBR (Standard)
V = FKM (optional)

Coil voltage _____
0 = without coil (with nut and Seals)
DC: 12 = 12 Volt DC voltage
24 = 24 Volt DC voltage
AC: 115 = 105 Volt DC voltage
230 = 205 Volt DC voltage (at AC voltage plug with suppressor diode necessary Mat. 2600582)

Coil connector (Coil... 32-1329) _____
DC: DG = DIN Plug to EN175301-803 Form B
DL = 2 leadwires, 450mm long
DN = Deutsch Plug, axial (Type DT04-2P)

Standard models

Code	Part No.
WK06W-01-C-N-0 without coil	2610182

(coil please choose from brochure D 5.155.0)
Other types on request

*Line bodies

Code	Part No.	Material	Ports	Pressure
FH062-SB2	3740528	steel, zinc plated	G1/4	420 bar
FH062-AB2	3741297	Alu, anodized	G1/4	245 bar

other line bodies on request

Seal kits

Code	Part No.
Seal kit-NBR	2610184
Seal kit-FKM	2610185

PERFORMANCE

Measured at 28 mm²/s and T oil = 38°C

